

1290 Super Adventure R

Art. no. 3213754en



KTM

Congratulations on your decision to purchase a KTM motorcycle. You are now the owner of a state-of-the-art sports motorcycle that will give you enormous pleasure if you service and maintain it properly.

We hope you enjoy riding this motorcycle!

Please enter the serial numbers of your vehicle below.

Chassis number (📖 p. 34)	Dealer's stamp
Engine number (📖 p. 36)	
Key number (📖 p. 35)	

The Owner's Manual contained the latest information for this model series at the time of going to print. However, minor differences due to further developments in design cannot be ruled out completely.

All specifications are non-binding. KTM Sportmotorcycle GmbH specifically reserves the right to modify or delete technical specifications, prices, colors, forms, materials, services, designs, equipment, etc., without prior notice and without specifying reasons, to adapt these to local conditions, as well as to stop production of a particular model without prior notice. KTM accepts no liability for delivery options, deviations from figures and descriptions, misprints, and other errors. The models portrayed partly contain special equipment that does not belong to the regular scope of supply.

© 2017 KTM Sportmotorcycle GmbH, Mattighofen Austria
All rights reserved



3213754en

10/2017

DEAR KTM CUSTOMER

Reproduction, even in part, as well as copying of all kinds, is permitted only with the express written permission of the copyright owner.



REG.NO. 12 100 6061

KTM Sportmotorcycle GmbH
Stallhofnerstraße 3
5230 Mattighofen, Austria

ISO 9001(12 100 6061)

According to the international quality management standard ISO 9001, KTM uses quality assurance processes that lead to the maximum possible quality of the products.

Issued by: TÜV Management Service

This document is valid for the following models:

1290 Super Adventure R TKC US (F9975R6)

1	MEANS OF REPRESENTATION	11	3.4	Service	28
	1.1 Symbols used	11	3.5	Figures	28
	1.2 Formats used.....	12	3.6	Customer service.....	28
2	SAFETY ADVICE.....	13	4	VIEW OF VEHICLE	30
	2.1 Use definition – intended use.....	13	4.1	View of vehicle, front left (example) ...	30
	2.2 Misuse.....	13	4.2	View of vehicle, rear right (example).....	32
	2.3 Safety advice.....	13	5	SERIAL NUMBERS	34
	2.4 Degrees of risk and symbols	14	5.1	Chassis number	34
	2.5 Overview of labels	16	5.2	Type label	34
	2.6 Consumer rights.....	21	5.3	Key number.....	35
	2.7 Operating noise warning	22	5.4	Engine number	36
	2.8 Noise emission warranty	22	5.5	Fork part number	36
	2.9 Reporting safety defects	22	5.6	Shock absorber article number	37
	2.10 Tampering warning.....	23	5.7	Steering damper article number	37
	2.11 Safe operation	24	6	CONTROLS.....	38
	2.12 Protective clothing	25	6.1	Clutch lever.....	38
	2.13 Work rules.....	25	6.2	Hand brake lever.....	38
	2.14 Environment.....	26	6.3	Throttle grip	39
	2.15 Owner's Manual	26	6.4	Combination switch, left side	39
3	IMPORTANT NOTES.....	27	6.5	Light switch	40
	3.1 Warranty	27	6.6	Cruise control system tip switch	41
	3.2 Operating and auxiliary substances	27	6.7	Menu switch.....	44
	3.3 Spare parts, accessories	27			

TABLE OF CONTENTS

6.8	Turn signal switch.....	44	7	COMBINATION INSTRUMENT	64
6.9	Horn button.....	46	7.1	Combination instrument	64
6.10	Combination switch, right	46	7.2	Activation and test	65
6.11	Hazard warning flasher switch	47	7.3	Day-Night mode.....	67
6.12	Emergency OFF switch/electric starter button	48	7.4	Warning notes.....	68
6.13	Race-on tip switch	49	7.5	Ice warning	69
6.14	Steering lock (antenna).....	50	7.6	Indicator lamps.....	70
6.15	Immobilizer	51	7.7	Display	74
6.16	Race-on key	51	7.8	Speed	76
6.17	Socket for electrical accessories	52	7.9	Shift warning light	77
6.18	USB socket	53	7.10	Cruise control indicator.....	78
6.19	Opening the filler cap.....	53	7.11	Speed	79
6.20	Closing the filler cap	55	7.12	ABS display.....	79
6.21	Fuel cocks.....	56	7.13	MTC display	80
6.22	Opening storage compartment	56	7.14	Ride display	80
6.23	Closing storage compartment	57	7.15	Heated grip (optional).....	81
6.24	Seat lock.....	57	7.16	Seat heater (optional).....	81
6.25	Grab handles	58	7.17	Coolant temperature indicator	82
6.26	Luggage rack plate	58	7.18	Fuel level display	82
6.27	Case holders.....	59	7.19	Ambient air temperature indicator	83
6.28	Passenger footrest.....	60	7.20	Time.....	84
6.29	Shift lever	60	7.21	Favourites display	84
6.30	Foot brake lever	61	7.22	Quick Selector 1 display	85
6.31	Side stand.....	62	7.23	Quick Selector 2 display	85
6.32	Center stand.....	63	7.24	Navigation-Display (optional).....	86

7.25	Menu.....	87	7.25.25	Ride Mode	114
7.25.1	KTM MY RIDE (optional)	87	7.25.26	MTC	115
7.25.2	Audio (optional).....	88	7.25.27	MTC+MSR (optional).....	116
7.25.3	Navigation (optional).....	90	7.25.28	ABS.....	117
7.25.4	Navigation setup (optional)	91	7.25.29	HHC (optional)	119
7.25.5	Navigation information (optional)	93	7.25.30	Settings	119
7.25.6	Volume (optional)	94	7.25.31	Favourites	120
7.25.7	Setup (optional).....	95	7.25.32	Navigation Info Screen	120
7.25.8	Bluetooth (optional)	96	7.25.33	Quick Selector 1	121
7.25.9	Phone (optional)	97	7.25.34	Quick Selector 2.....	122
7.25.10	Headset Rider (optional).....	99	7.25.35	Preferences.....	123
7.25.11	Headset Pass. (optional).....	101	7.25.36	Units	123
7.25.12	Wireless Interface	103	7.25.37	Distance	124
7.25.13	Telephony (optional)	104	7.25.38	Temperature.....	124
7.25.14	Info	105	7.25.39	Pressure	125
7.25.15	Trip 1	106	7.25.40	Consumption	126
7.25.16	Trip 2	107	7.25.41	Language	126
7.25.17	General Info	108	7.25.42	Shift Light	127
7.25.18	TPMS	108	7.25.43	Setting the time and date	128
7.25.19	Warnings.....	110	7.25.44	DRL	130
7.25.20	Service	110	7.25.45	Quickshifter + (optional).....	131
7.25.21	Extra Functions	111	7.25.46	Heated Grips (optional)	132
7.25.22	Motorcycle	112	7.25.47	Heated Seat Rid (optional).....	132
7.25.23	Heated Grips (optional)	112	7.25.48	Heated Seat Pas (optional)	133
7.25.24	Heated Seat (optional)	113	7.25.49	Cornering Light Test.....	133

TABLE OF CONTENTS

8	ERGONOMICS	135	10	RIDING INSTRUCTIONS.....	156
8.1	Handlebar position.....	135	10.1	Checks and maintenance measures when preparing for use	156
8.2	Adjusting the handlebar position 🖱.....	135	10.2	Starting.....	157
8.3	Adjusting the windshield	138	10.3	Starting off.....	160
8.4	Adjusting the basic position of the clutch lever	139	10.4	Quickshifter + (optional).....	161
8.5	Adjusting the basic position of the hand brake lever	140	10.5	Starting off with HHC (optional)	162
8.6	Rider footrests.....	140	10.6	Shifting, riding	163
8.7	Adjusting the footrests 🖱.....	141	10.7	MSR (optional)	169
8.8	Checking the basic position of the shift lever.....	144	10.8	Applying the brakes.....	170
8.9	Adjusting the basic position of the shift lever 🖱.....	145	10.9	Stopping, parking.....	173
8.10	Setting the shift lever stub.....	147	10.10	Transporting.....	175
8.11	Adjusting the basic position of the foot brake lever 🖱.....	148	10.11	Refueling	176
8.12	Adjusting the tilt of the combination instrument.....	149	11	SERVICE SCHEDULE	179
9	PREPARING FOR USE.....	151	11.1	Additional information	179
9.1	Advice on preparing for first use	151	11.2	Required work	179
9.2	Running in the engine	153	11.3	Recommended work	182
9.3	Loading the vehicle	153	12	SUSPENSION SETTING.....	183
			12.1	Fork/shock absorber	183
			12.2	Adjusting the compression damping of the fork.....	183
			12.3	Adjusting the rebound damping of the fork.....	185

12.4	Adjusting the spring pretension of the fork.....	186	13.9	Checking the chain, rear sprocket, and engine sprocket	201
12.5	Compression damping of the shock absorber.....	187	13.10	Checking/correcting the fluid level of the hydraulic clutch.....	204
12.6	Adjusting the low-speed compression damping of the shock absorber.....	188	13.11	Checking the steering head bearing play	206
12.7	Adjusting the high-speed compression damping of the shock absorber.....	189	13.12	Removing the bottom triple clamp cover	207
12.8	Adjusting the rebound damping of the shock absorber.....	191	13.13	Installing the bottom triple clamp cover	208
12.9	Adjusting the spring pretension of the shock absorber.....	192	13.14	Removing the front side cover	209
13	SERVICE WORK ON THE CHASSIS.....	193	13.15	Installing the front side cover.....	210
13.1	Raising the vehicle with the center stand	193	13.16	Removing the mask spoiler 🛠.....	211
13.2	Removing the vehicle from the center stand	194	13.17	Installing the mask spoiler 🛠.....	215
13.3	Removing the seat	195	13.18	Removing front fender	218
13.4	Mounting the seat	195	13.19	Installing front fender.....	218
13.5	Checking for chain dirt	196	13.20	Cleaning the dust boots of the fork legs 🛠.....	219
13.6	Cleaning the chain	196	13.21	Removing the tank cover.....	220
13.7	Checking the chain tension	198	13.22	Installing the tank cover	223
13.8	Adjusting the chain tension.....	199	13.23	Removing the wind shield	225
			13.24	Installing the wind shield.....	225
			13.25	Removing the engine guard.....	226
			13.26	Installing the engine guard	226
			13.27	Removing the crash bar 🛠.....	227
			13.28	Installing the crash bar 🛠.....	228

TABLE OF CONTENTS

14	BRAKE SYSTEM	231	16	ELECTRICAL SYSTEM	264
14.1	Antilock brake system (ABS)	231	16.1	Daytime running light (DRL).....	264
14.2	Checking the brake discs	234	16.2	Cornering headlight	265
14.3	Checking the brake fluid level of the front brake.....	235	16.3	Removing the battery 🛠.....	266
14.4	Adding front brake fluid 🛠.....	236	16.4	Installing the battery 🛠.....	268
14.5	Checking the front brake linings	239	16.5	Recharging the battery 🛠.....	271
14.6	Checking the rear brake fluid level	240	16.6	Changing the Race-on key battery....	276
14.7	Adding rear brake fluid 🛠.....	241	16.7	Changing the main fuse	277
14.8	Checking the rear brake linings	244	16.8	Changing the fuses in the fuse box	280
15	WHEELS, TIRES	245	16.9	Changing the turn signal bulb	283
15.1	Removing the front wheel 🛠.....	245	16.10	Checking the headlight setting	285
15.2	Installing the front wheel 🛠.....	247	16.11	Adjusting the headlight range.....	286
15.3	Removing the rear wheel 🛠.....	251	16.12	Diagnostics connector	287
15.4	Installing the rear wheel 🛠.....	254	16.13	Front ACC1 and ACC2	287
15.5	Checking the rear hub rubber dampers 🛠.....	257	16.14	ACC1 and ACC2 rear	288
15.6	Checking the tire condition	258	17	COOLING SYSTEM	289
15.7	Checking the tire air pressure.....	261	17.1	Checking the coolant level in the compensating tank.....	289
15.8	Checking spoke tension	262	17.2	Correcting the coolant level in the compensating tank.....	291
15.9	Tubeless tire system.....	263	18	TUNING THE ENGINE	294
			18.1	Ride Mode	294

18.2	Motorcycle traction control (MTC)....	295	23.4	Chassis	327
19	SERVICE WORK ON THE ENGINE	296	23.5	Electrical system.....	328
19.1	Checking the engine oil level.....	296	23.6	Tires	330
19.2	Changing the engine oil and oil filter, cleaning the oil screens 🐾.....	297	23.7	Fork.....	330
19.3	Adding engine oil	304	23.8	Shock absorber	331
20	CLEANING, CARE	307	23.9	Chassis tightening torques	333
20.1	Cleaning motorcycle	307	24	DECLARATIONS OF CONFORMITY	339
20.2	Checks and maintenance steps for winter operation.....	310	24.1	Declarations of conformity	339
21	STORAGE.....	312	25	OPEN SOURCE	343
21.1	Storage	312	25.1	Information on open source software	343
21.2	Preparing for use after storage.....	314	26	SUBSTANCES	344
22	TROUBLESHOOTING	315	27	AUXILIARY SUBSTANCES	348
23	TECHNICAL DATA	319	28	STANDARDS	350
23.1	Engine	319	29	INDEX OF SPECIAL TERMS	351
23.2	Engine tightening torques	321	30	LIST OF ABBREVIATIONS.....	353
23.3	Capacities	326	31	LIST OF SYMBOLS.....	354
23.3.1	Engine oil	326	31.1	Red symbols.....	354
23.3.2	Coolant	326	31.2	Yellow and orange symbols.....	354
23.3.3	Fuel	327	31.3	Green and blue symbols.....	355

TABLE OF CONTENTS

INDEX.....	356
------------	-----

1.1 Symbols used

The meaning of specific symbols is described below.



Indicates an expected reaction (e.g. of a work step or a function).



Indicates an unexpected reaction (e.g. of a work step or a function).



All work marked with this symbol requires specialist knowledge and technical understanding. In the interest of your own safety, have these jobs performed by an authorized KTM workshop! Your motorcycle will be optimally cared for there by specially trained experts using the auxiliary tools required.



Indicates a page reference (more information is provided on the specified page).



Indicates information with more details or tips.



Indicates the result of a testing step.

1 MEANS OF REPRESENTATION

V

Indicates a voltage measurement.

A

Indicates a current measurement.



Indicates the end of an activity, including potential rework.

1.2 Formats used

The typographical formats used in this document are explained below.

Proprietary name

Indicates a proprietary name.

Name®

Indicates a protected name.

Brand™

Indicates a brand available on the open market.

Underlined terms

Refer to technical details of the vehicle or indicate technical terms, which are explained in the glossary.

2.1 Use definition – intended use

The vehicle is designed and constructed to withstand the usual demands of regular traffic and use on gentle terrain (unpaved roads). This vehicle is not suitable for use on race tracks.



Info

This vehicle is only authorized for operation on public roads in its homologated version.

2.2 Misuse

The vehicle must only be used as intended.

Dangers can arise for people, property and the environment through use not as intended.

Any use of the vehicle beyond the intended and defined use constitutes misuse.

Misuse also includes the use of operating and auxiliary fluids which do not meet the required specification for the respective use.

2.3 Safety advice

A number of safety instructions need to be followed to operate the model described safely. Therefore read this instruction and all further instructions included carefully. The safety instructions are highlighted in the text and are referred to at the relevant passages.

2 SAFETY ADVICE



Info

Various information and warning labels are attached in prominent locations on the model described. Do not remove any information or warning labels. If they are missing, you or others may not recognize dangers and may therefore be injured.

2.4 Degrees of risk and symbols



Danger

Indicates a danger that will immediately and invariably lead to fatal or serious permanent injury if the appropriate measures are not taken.



Warning

Indicates a danger that is likely to lead to fatal or serious injury if the appropriate measures are not taken.



Caution

Indicates a danger that may lead to minor injuries if the appropriate measures are not taken.

Note

Indicates a danger that will lead to considerable machine and material damage if the appropriate measures are not taken.



Warning

Indicates a danger that will lead to environmental damage if the appropriate measures are not taken.

2 SAFETY ADVICE

2.5 Overview of labels

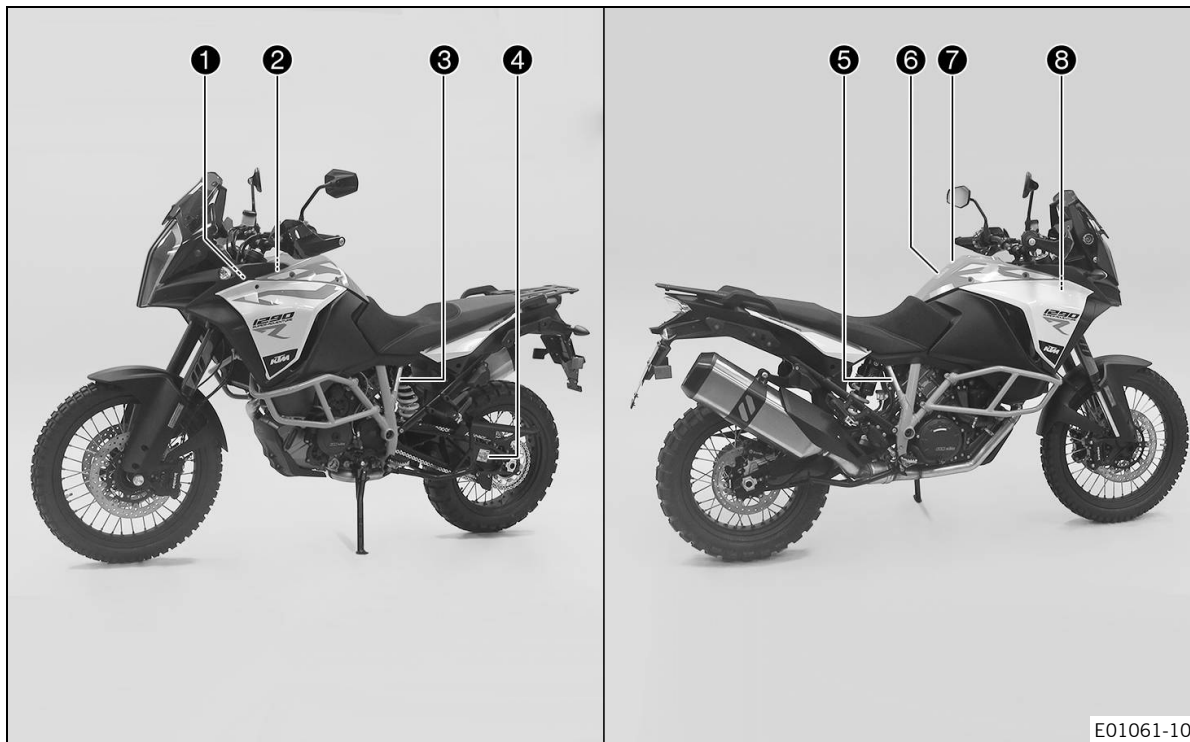

1	Information on suspension tuning
2	Canada type label
3	Information on emission control
4	Information on chain tension
5	Information on noise emission
6	Information on starting up
7	Information on tires
8	USA type label

Information on suspension tuning

SETTING look owner's manual	ADVENTURE R 607.03.097.000			FORK			SHOCK			
	Compression	Rebound	Spring preload (turns)	Compression low speed	Compression high speed	Rebound	Spring preload (mm)	Preload Adjuster (turns)		
Comfort	17	17	2	20	1,5	20	11	2		
Basic setting	12	12	5	15	1,5	15	11	2		
Sport	7	7	5	10	1	10	11	2		
Max. payload	7	7	8	10	1	10	16	12		

S01760-01

2 SAFETY ADVICE

MANUFACTURED BY/FABRIQUÉ PAR:		KTM AG	
GVWR/PNBV: 450 KG		DATE: mm/jj	
V.I.N./N.I.V.: VBKxxxxxxMxxxxx			
TYPE: MC			
GAWR/PNBE		TIRE/PNEU-DIMENSION-RIM/JANTE	
		COLD INFL. PRESS. PRESS. DE GONFL. À FROID	
		PSI/LPC KPA	
1st	165 KG	90/90-21	2.50x21
			38 260
2nd	285 KG	150/70B18	4.50x18
			42 290
THIS VEHICLE CONFORMS TO ALL APPLICABLE STANDARDS PRESCRIBED UNDER THE CANADIAN MOTOR VEHICLE SAFETY REGULATIONS IN EFFECT ON THE DATE OF MANUFACTURE - CE VÉHICULE EST CONFORME À TOUTES LES NORMES QUI LUI SONT APPLICABLES EN VERTU DU RÈGLEMENT SUR LA SÉCURITÉ DES VÉHICULES AUTOMOBILES DU CANADA EN VIGUEUR À LA DATE DE SA FABRICATION			

S02246-01

Canada type label

VEHICLE EMISSION CONTROL INFORMATION			
KTM MANUFACTURER: KTM AG, Mattighofen, Austria			
IMPORTER: KTM NORTH AMERICA, INC.			
ENGINE DISPLACEMENT	1301 cc	ENGINE EXHAUST EMISSION CONTROL SYSTEM:	
ENGINE FAMILY	JKTXG1308AR	TWC, PAIR, 8FI, 2HO2S	
EVAPORATIVE FAMILY	JKTXG0458AR		
PERMEATION FAMILY	JKTXPP104R27	MODEL NAME	1290 SUPER ADVENTURE R
THIS VEHICLE CONFORMS WITH US EPA AND CALIFORNIA REGULATIONS APPLICABLE TO 2018 MODEL YEAR NEW MOTORCYCLES AND IS CERTIFIED TO 0.8 G/KM HC+NOX, 12 G/KM CO EXHAUST EMISSION STANDARDS IN CALIFORNIA.			
ENGINE TUNEUP SPECIFICATIONS:			
IGNITION TIMING	NON ADJUSTABLE		
IDLE SPEED:	1380 +/-100 RPM IN NEUTRAL		
IDLE MIXTURE:	NON ADJUSTABLE		
VALVE CLEARANCE:	0.10 - 0.15 mm INTAKE	0.25 - 0.30 mm EXHAUST	
SPARK PLUG:	(central) NGK LKAR9B1-10, (outer) NGK LMAR7D1-10		
SPARK PLUG GAP:	1.00 mm		
FUEL:	UNLEADED GASOLINE ONLY - 91 (R+M)/2 OCTANE OR HIGHER		
OIL:	SAE 10 W 50		

F01343-01

Information on emission control

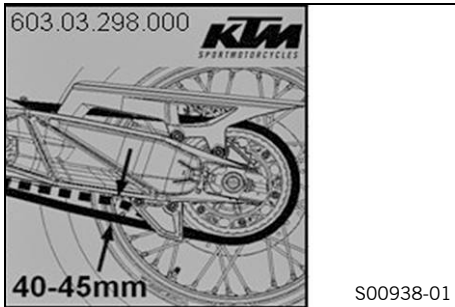

Information on chain tension

MOTORCYCLE NOISE EMISSION CONTROL INFORMATION KTM AG, AUSTRIA
THIS 2018 KTM6071301 MOTORCYCLE, 603.05.183.000 MEETS EPA NOISE EMISSION REQUIREMENTS OF 80 dBA AT 4840 RPM BY THE FEDERAL TEST PROCEDURE. MODIFICATIONS WHICH CAUSE THIS MOTORCYCLE TO EXCEED FEDERAL NOISE STANDARDS ARE PROHIBITED BY U.S. FEDERAL LAW. SEE OWNER'S MANUAL.
Motorcycle Type : 1290 Super Adventure R
S02248-01

Information on noise emission

2 SAFETY ADVICE

ACHTUNG
Lesen Sie vor der ersten Inbetriebnahme des Fahrzeuges die gesamte Bedienungsanleitung aufmerksam durch!

IMPORTANT
Please read the entire owner's manual carefully before putting the vehicle into operation for the first time.

ATTENZIONE
Prima della messa in funzione iniziale del veicolo, leggere con attenzione l'intero manuale d'uso!

ATTENTION
Lire attentivement l'ensemble du manuel d'utilisation avant de mettre le véhicule en service!

ATENCIÓN
Lea completa y atentamente el manual de instrucciones antes de poner en servicio por primera vez el vehículo!

S00940-01

Information on starting up

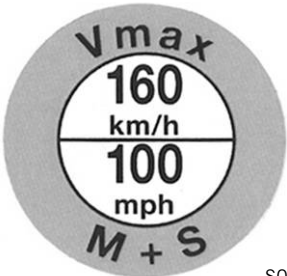

S01763-01

Information on tires

	MFD. BY KTM AG AUSTRIA				DATE	mm/jj
	MOTORCYCLE					
GVWR	992 lbs	450 kg				
GAWR FRONT	363 lbs	165 kg WITH	90/90-21 TIRE,	54T TYPE,		
	2.50x21 RIM, AT	38 psi 2.6 bar COLD				
GAWR REAR	628 lbs	285 kg WITH	150/70B18 TIRE,	70Q TYPE,		
	4.50x18 RIM, AT	42 psi 2.9 bar COLD				
THIS VEHICLE CONFORMS TO ALL APPLICABLE U.S. FEDERAL MOTOR VEHICLE SAFETY STANDARDS IN EFFECT ON THE DATE OF MANUFACTURE SHOWN ABOVE.						
VBKxxxxxxxMxxxxxx						S02249-01

USA type label

2.6 Consumer rights

Warranty claims should be submitted to a KTM workshop. If you are not satisfied, please contact:
 KTM North America, Inc., Customer Support, 1119 Milan Ave., Amherst, OH 44001, USA
 Phone: (440) 985-3553
www.ktmusa.com

KTM Canada, Inc., Customer Support, 1375-1 Marie-Victorin, Saint-Bruno, QC J3V 6B7
 Phone: (450) 441-4451 x 4250
www.ktmcanada.com

Different rights may apply, according to national or regional legislation.

2.7 Operating noise warning

This product should be checked for necessary repair or replacement parts if the motorcycle noise has increased significantly through use. Otherwise, the owner may become subject to penalties under the applicable ordinances.

2.8 Noise emission warranty

KTM Sportmotorcycle AG warrants that this exhaust system, at the time of sale, meets all applicable U.S. EPA Federal noise standards.

This warranty extends to the first person who buys this exhaust system for purposes other than resale, and to all subsequent buyers.

Warranty claims should be directed to:

KTM North America, Inc., Customer Support, 1119 Milan Ave., Amherst, OH 44001, USA

Phone: (440) 985-3553

www.ktmusa.com

KTM Canada, Inc., Customer Support, 1375-1 Marie-Victorin, Saint-Bruno, QC J3V 6B7

Phone: (450) 441-4451 x 4250

www.ktmcanada.com

2.9 Reporting safety defects

If you believe that your vehicle has a defect which could cause an accident resulting in injury or death, you should immediately inform the National Highway Traffic Safety Administration (NHTSA) in addition to notifying KTM North America, Inc.

If NHTSA receives multiple similar complaints, it may open an investigation, and if it finds that a safety defect exists in a group of vehicles, it may order a recall and remedy campaign. However, NHTSA cannot become involved in individual problems between you, your dealer, or KTM North America, Inc.

To contact NHTSA, you may either call the Auto Safety Hotline toll-free at 1-888-327-4236 or visit the website www.nhtsa.dot.gov, or write to: NHTSA Headquarters, 1200 New Jersey Avenue, SE, West Building, Washington, DC 20590. You can also obtain other information about motor vehicle safety from the Hotline.

2.10 Tampering warning

Tampering with the noise control system is prohibited. Federal law prohibits the following acts or the causing thereof:

- 1 The removal or rendering inoperative by any person other than for purposes of maintenance, repair, or replacement, of any device or element of design incorporated into any new vehicle for the purpose of noise control prior to its sale or delivery to the ultimate purchaser or while it is in use, or
- 2 the use of the vehicle after such device or element of design has been removed or rendered inoperative by any person.

Among those acts presumed to constitute tampering are the acts listed below:

- 1 Removal or puncturing of the main silencer, baffles, header pipes or any other components which conduct exhaust gases.
- 2 Removal or puncturing of parts of the intake system.
- 3 Lack of proper maintenance.
- 4 Replacing moving part of the vehicle, or parts of the exhaust or intake system, with parts other than those specified by the manufacturer.

2.11 Safe operation



Danger

Danger of accidents A rider who is not fit to ride poses a danger to him or herself and others.

- Do not operate the vehicle if you are not fit to ride due to alcohol, drugs or medication.
- Do not operate the vehicle if you are physically or mentally impaired.



Danger

Danger of poisoning Exhaust gases are toxic and inhaling them may result in unconsciousness and death.

- Always make sure there is sufficient ventilation when running the engine.
- Use an effective exhaust extraction system when starting or running the engine in an enclosed space.



Warning

Danger of burns Some vehicle components become very hot when the vehicle is operated.

- Do not touch any parts such as the exhaust system, radiator, engine, shock absorber, or brake system before the vehicle parts have cooled down.
- Let the vehicle parts cool down before you perform any work on the vehicle.

Only operate the vehicle when it is in perfect technical condition, in accordance with its intended use, and in a safe and environmentally compatible manner.

The vehicle should only be used by trained persons. An appropriate driver's license is needed to ride the vehicle on public roads.

Have malfunctions that impair safety promptly eliminated by an authorized KTM workshop.

Adhere to the information and warning labels on the vehicle.

2.12 Protective clothing



Warning

Risk of injury Missing or poor protective clothing presents an increased safety risk.

- Wear appropriate protective clothing such as helmet, boots, gloves as well as trousers and a jacket with protectors on all rides.
- Always wear protective clothing that is in good condition and meets the legal regulations.

In the interest of your own safety, KTM recommends that you only operate the vehicle while wearing protective clothing.

2.13 Work rules

Special tools are necessary for some of the work. These are not included with the vehicle and can be ordered under the number in parentheses. Ex: valve spring mounter (59029019000)

During assembly, non-reusable parts (e.g. self-locking screws and nuts, seals and seal rings, O-rings, pins, lock washers) must be replaced by new parts.

Where thread lockers are used on screw connections (e.g., **Loctite**®), follow the instructions for use from the manufacturer.

Parts that you want to reuse following repairs and servicing should be cleaned and checked for damage and wear. Change damaged or worn parts.

Following repairs or servicing, the vehicle must be checked for roadworthiness.

2.14 Environment

If you use your motorcycle responsibly, you can ensure that problems and conflicts do not occur. To protect the future of the motorcycle sport, make sure that you use your motorcycle legally, display environmental consciousness, and respect the rights of others.

When disposing of used oil, other operating and auxiliary fluids, and used components, comply with the laws and regulations of the respective country.

Because motorcycles are not subject to the EU regulations governing the disposal of used vehicles, there are no legal regulations that pertain to the disposal of an end-of-life motorcycle. Your authorized KTM dealer will be glad to advise you.

2.15 Owner's Manual

It is important that you read this Owner's Manual carefully and completely before making your first trip. The Owner's Manual contains useful information and many tips on how to operate, handle, and maintain your motorcycle. Only then will you find out how to customize the vehicle ideally for your own use and how you can protect yourself from injury.

Keep the Owner's Manual in an accessible place to enable you to refer to it as needed.

If you would like to know more about the vehicle or have questions on the material you read, please contact an authorized KTM dealer.

The Owner's Manual is an important component of the vehicle and must be handed over to the new owner if the vehicle is sold.

The Owner's Manual is also available for download from your authorized KTM dealer and on the KTM website. International KTM Website: <http://www.ktm.com>

3.1 Warranty

The work specified in the service schedule may only be performed in an authorized KTM workshop and must be recorded in both the Service & Warranty Booklet and in **KTM Dealer.net**, otherwise any warranty coverage will become void. No warranty claims can be considered for damage resulting from manipulations and/or alterations to the vehicle.

Additional information on the manufacturer or implied warranty and the procedures involved can be found in the service & warranty booklet.

3.2 Operating and auxiliary substances



Warning

Environmental hazard Improper handling of fuel is a danger to the environment.

- Do not allow fuel to enter the groundwater, the soil, or the sewage system.

Use operating and auxiliary substances in accordance with the Owner's Manual and specification.

3.3 Spare parts, accessories

For your own safety, only use spare parts and accessory products that are approved and/or recommended by KTM and have them installed by an authorized KTM workshop. KTM accepts no liability for other products and any resulting damage or loss.

Certain spare parts and accessory products are specified in parentheses in the descriptions. Your authorized KTM dealer will be glad to advise you.

3 IMPORTANT NOTES

The current **KTM PowerParts** for your vehicle can be found on the KTM website.
International KTM Website: <http://www.ktm.com>

3.4 Service

A prerequisite for perfect operation and prevention of premature wear is that the service, care and tuning work on the engine and chassis are properly carried out as described in the owner's manual. Poor adjustment and tuning of the engine and suspension can lead to damage and breakage of components.

Using the motorcycle in extreme operating conditions, e.g. on very muddy and wet roads or in a dusty and dry environment, can lead to above-average wear of components, such as the drive train, brakes or air filter. For this reasons, it may be necessary to service or replace worn parts before the interval listed in the service schedule is reached.

It is imperative that you adhere to the stipulated run-in times and service intervals. If you observe these exactly, you will ensure a much longer service life for your motorcycle.

3.5 Figures

The figures contained in the manual may depict special equipment.

In the interest of clarity, some components may be shown disassembled or may not be shown at all. It is not always necessary to disassemble the component to perform the activity in question. Please follow the instructions in the text.

3.6 Customer service

Your authorized KTM dealer will be happy to answer any questions you may have on your vehicle and KTM.

A list of authorized KTM dealers can be found on the KTM website.
International KTM Website: <http://www.ktm.com>

4 VIEW OF VEHICLE

4.1 View of vehicle, front left (example)

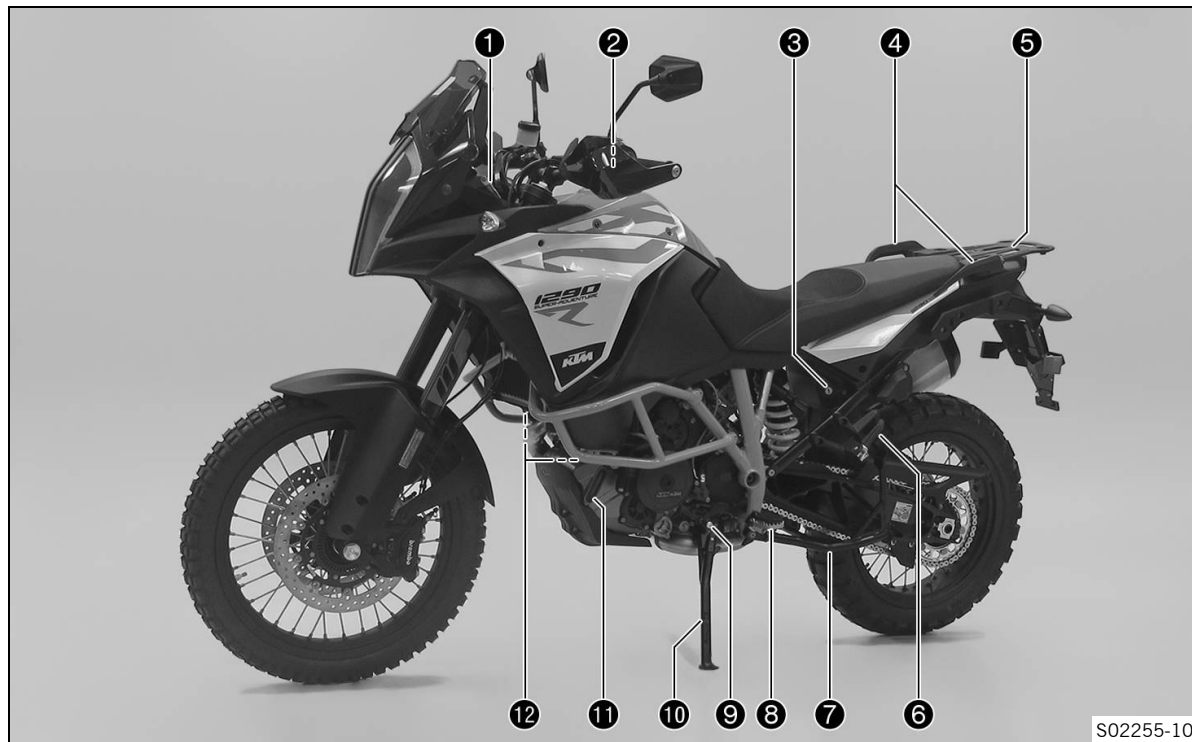

- ❶ Socket for electrical accessories (📖 p. 52)
- ❷ Clutch lever (📖 p. 38)
- ❸ Seat lock (📖 p. 57)
- ❹ Grab handles (📖 p. 58)
- ❺ Luggage rack plate (📖 p. 58)
- ❻ Passenger footrest (📖 p. 60)
- ❼ Center stand (📖 p. 63)
- ❽ Rider footrests (📖 p. 140)
- ❾ Shift lever (📖 p. 60)
- ❿ Side stand (📖 p. 62)
- ⓫ Engine oil level viewer
- ⓬ Fuel cocks (📖 p. 56)

4 VIEW OF VEHICLE

4.2 View of vehicle, rear right (example)

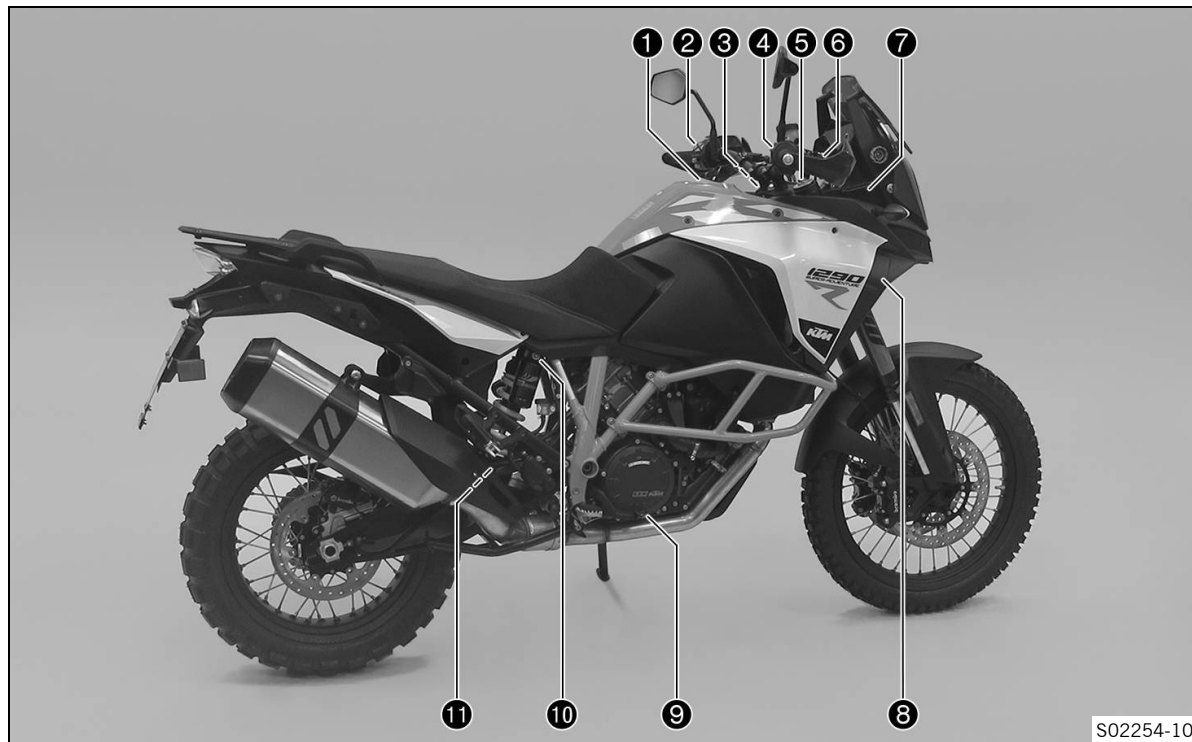

- ① Filler cap
- ② Combination switch, left side (📖 p. 39)
- ③ Fork compression adjuster
- ④ Combination switch, right (📖 p. 46)
- ⑤ Fork rebound adjustment
- ⑥ Hand brake lever (📖 p. 38)
- ⑦ Storage compartment
- ⑧ Cooling system compensating tank
- ⑨ Foot brake lever (📖 p. 61)
- ⑩ Shock absorber compression adjustment
- ⑪ Shock absorber rebound adjustment

5 SERIAL NUMBERS

5.1 Chassis number

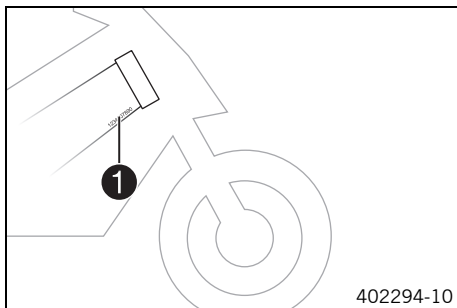

The chassis number **1** is stamped on the bottom right of the frame behind the steering head.

The chassis number is also shown on the type label.

5.2 Type label

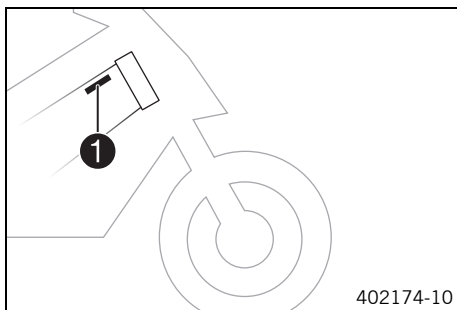

Type label USA **1** is affixed to the frame behind the steering head at the top right.

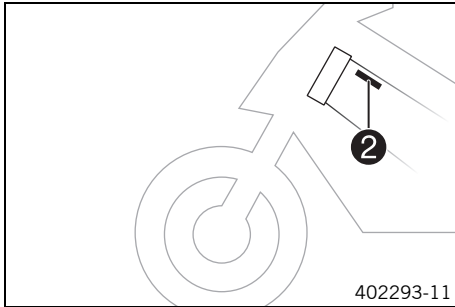

Type label Canada **2** is affixed to the frame behind the steering head at the top left.

5.3 Key number

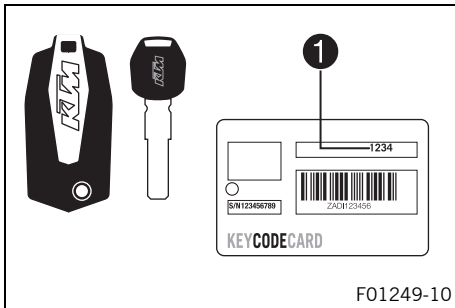

The key number **Code number 1** can be found on the **KEYCODECARD**.



Info

You need the key number to order a spare key. Keep the **KEYCODECARD** in a safe place.

5 SERIAL NUMBERS

5.4 Engine number

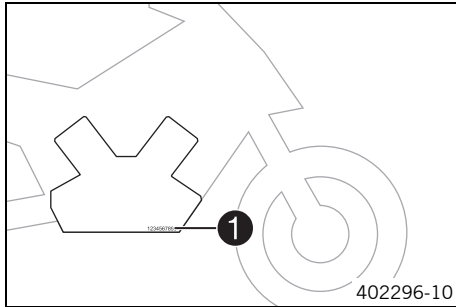

The engine number **1** is stamped on the right side of the engine.

5.5 Fork part number

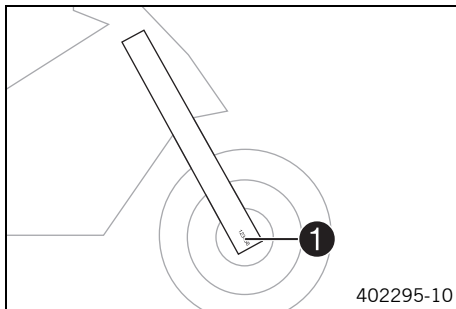

The fork part number **1** is stamped on the inner side of the fork stub.

5.6 Shock absorber article number

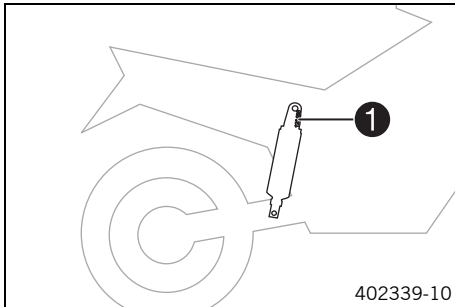

The shock absorber article number **1** is stamped on the top of the shock absorber above the adjusting ring towards the engine side.

5.7 Steering damper article number

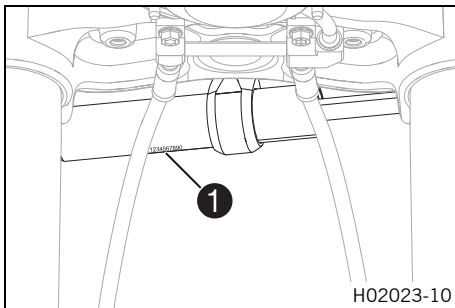

Steering damper article number **1** is embossed on the underside of the steering damper.

6 CONTROLS

6.1 Clutch lever

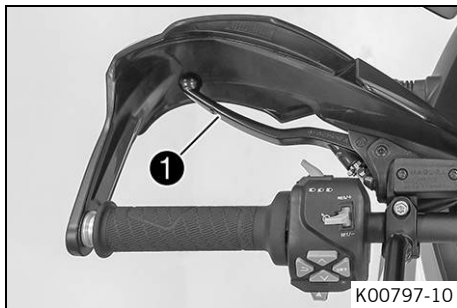

The clutch lever **1** is fitted on the left side of the handlebar. The clutch is hydraulically operated and self-adjusting.

6.2 Hand brake lever

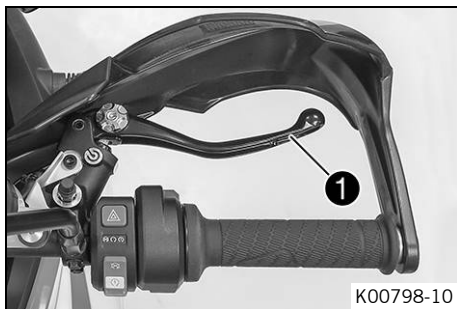

The hand brake lever **1** is fitted on the right side of the handlebar.

The hand brake lever is used to activate both the front brake and rear brake at the same time.

i Info

When the ABS mode **Offroad** is switched on, only the front brake is activated.

When ABS is switched off, only the front brake is activated.

6.3 Throttle grip

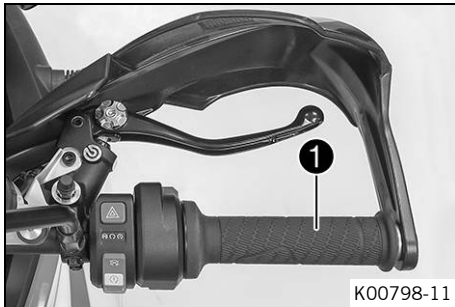

The throttle grip **1** is fitted on the right side of the handlebar.

6.4 Combination switch, left side

The left combination switch is fitted on the left side of the handlebar.

6 CONTROLS

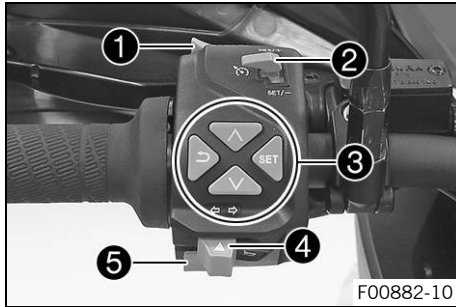

Overview of the left combination switch

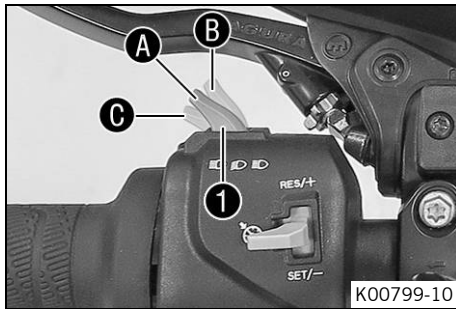

- ❶ Light switch (📖 p. 40)
- ❷ Cruise control system tip switch (📖 p. 41)
- ❸ Menu switch (📖 p. 44)
- ❹ Turn signal switch (📖 p. 44)
- ❺ Horn button (📖 p. 46)

6.5 Light switch



The light switch ❶ is fitted on the combination switch on the left.

Possible states







	Low beam on – Light switch in position A . In this position, the low beam and tail light are switched on.
	High beam on – Push the light switch to position B . In this position, the high beam and the tail light are switched on.
	Headlight flasher. – Push the light switch into position C .

6.6 Cruise control system tip switch



The cruise control system tip switch **1** is fitted on the left side of the combination switch.

Possible states

- Cruise control system tip switch  in the basic position.
- Cruise control system tip switch  pressed to the left. – In this position, the cruise control system function is switched on and off. The operating mode is displayed in the combination instrument.
- Briefly press cruise control system tip switch  at the top. – The last saved speed is reached and maintained. Every subsequent brief pressing increases the target speed by 1 km/h or 1 mph.
- Press and hold cruise control system tip switch  at the top. – The target speed increases in increments of 5 km/h or 5 mph.
- Briefly press cruise control system tip switch  at the bottom. – The cruise control system function is activated and the current speed is maintained. Every subsequent brief press reduces the target speed by 1 km/h or 1 mph.
- Press and hold cruise control system tip switch  at the bottom. – The target speed decreases in increments of 5 km/h or 5 mph.



Info

After activation of the cruise control system function, the throttle grip can be turned back to the home position. The selected speed will be maintained.

If the target speed is exceeded for less than 30 seconds when turning the throttle grip, the cruise control system remains activated.

To switch off the cruise control system function, press the cruise control system tip switch  to the left.

In addition, the cruise control system function is deactivated when one of the following events occurs:

- Operating the hand brake lever
 - Operating the foot brake lever
 - Operating the clutch lever
 - Shifting gears
 - Turning the throttle grip beyond the home position
 - Control of the motorcycle traction control (**MTC**  p. 295)
 - Slip at the rear wheel or lifting front wheel
 - A fault occurring, which impairs the cruise control system function
 - Exceeding the target speed for more than 30 seconds when overtaking
-



Warning

Danger of accidents The cruise control system function is not suitable for all driving situations.

The selected target speed will not be reached, if the engine power is not sufficient for a gradient.

The selected target speed will be exceeded if the engine braking effect is not sufficient on a decline.

- Do not use the cruise control systems function on winding roads.
- Do not use the cruise control systems on slippery road surfaces (e.g. rain, ice or snow) or unpaved surfaces (e.g. sand, stones or gravel).
- Do not use the cruise control systems function if the traffic does not permit a constant speed.

The cruise control system function is only available when motorcycle traction control (**MTC** (📖 p. 295)) is activated.

When motorcycle traction control (**MTC** (📖 p. 295)) is switched off, the cruise control system function is also switched off.

The cruise control system function cannot be activated during rapid acceleration.

The cruise control system function can only be activated in 3rd, 4th, 5th and 6th gear.

The control range is from 40 to 200 km/h or from 25 to 125 mph.

6 CONTROLS

6.7 Menu switch

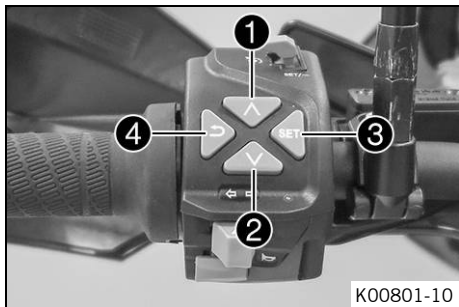

The menu switch is fitted in the middle of the left combination switch.

The menu buttons are used to control the matrix display on the combination instrument.

Button **1** is the **UP** button.

Button **2** is the **DOWN** button.

Button **3** is the **SET** button.

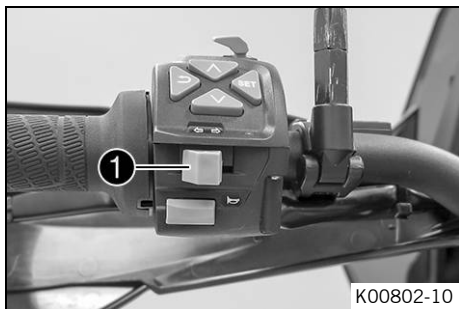

Button **4** is the **BACK** button.

6.8 Turn signal switch



Turn signal switch **1** is fitted on the combination switch on the left.

Possible states

	Turn signal off – Push the turn signal switch toward the switch housing.
	Left turn signal, on – Turn signal switch pressed to the left. The turn signal switch returns automatically to the central position after use.



Right turn signal, on – Turn signal switch pressed to the right. The turn signal switch returns automatically to the central position after use.



Info

An automatic turn signal switch-off function (**ATIR**) is available as a software feature.

The **ATIR** function uses a time and distance counter.

If the turn signal has been on for at least 10 seconds and 150 meters of riding distance, the turn signal is switched off.

If the vehicle is stationary, both counters are stopped.

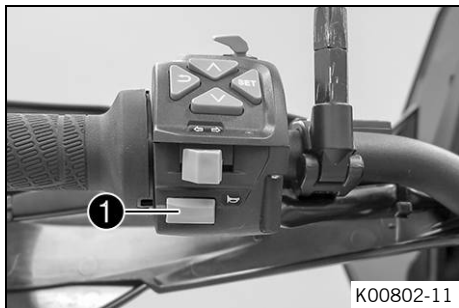

If the turn signal switch is reactivated, both counters are reset.

6.9 Horn button



The horn button ❶ is fitted on the combination switch on the left.

Possible states

- Horn button  in basic position.
- Horn button  pressed – The horn is operated in this position.

6.10 Combination switch, right

The right combination switch is fitted on the right side of the handlebar.

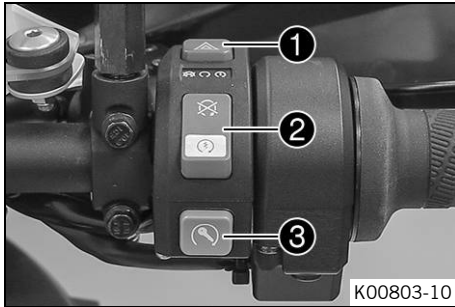

Overview of the right combination switch

- ① Hazard warning flasher switch (📖 p. 47)
- ② Emergency OFF switch/electric starter button (📖 p. 48)
- ③ Race-on tip switch (📖 p. 49)

6.11 Hazard warning flasher switch

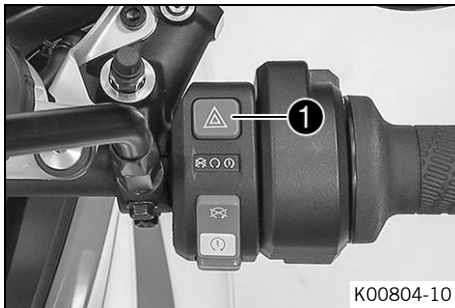

The hazard warning flasher switch ① is fitted on the right side of the combination switch. The hazard warning flasher is used to indicate emergency situations.

i Info

The hazard warning flasher can be activated or deactivated while the ignition is switched on or up to 60 seconds after the ignition is switched off. Only keep the hazard warning flasher activated as long as necessary as it depletes the battery.

Possible states



Hazard warning flasher on – All four turn signals and the green turn signal indicator lights in the combination instrument flash.

6.12 Emergency OFF switch/electric starter button

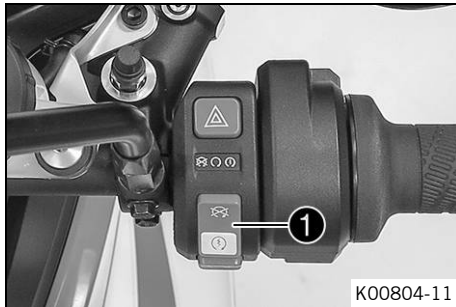

The emergency OFF switch/electric starter button **1** is fitted on the right side of the combination switch.

Possible states



Emergency OFF switch/electric starter button off (top position) – In this position, the ignition circuit is interrupted, a running engine stops, and a non-running engine cannot be started. A message appears on the display.



Emergency OFF switch/electric starter button on (middle position) – This position is required for operation; the ignition circuit is closed.



Starter motor on (lower position) – In this position, the starter motor is actuated.

6.13 Race-on tip switch

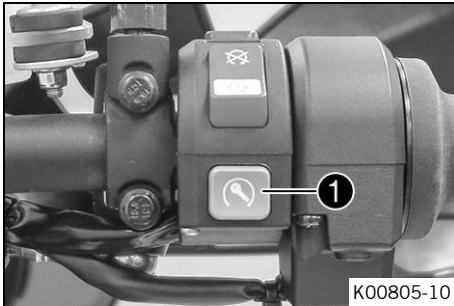

The Race-on tip switch ① is fitted on the right side of the combination switch.

i Info

The Race-on tip switch performs the ignition lock function on this vehicle.

The steering can only be locked if the handlebar is turned fully to the left.

Possible states

- Race-on tip switch ① in the basic position.
- Race-on tip switch ① pressed briefly – Pressing briefly switches the ignition on and unlocks the handlebar lock or switches the ignition off. The Race-on indicator lamp lights up briefly once for confirmation.
- Race-on tip switch ① pressed and held – Pressing and holding switches the ignition off and locks the handlebar.

6.14 Steering lock (antenna)

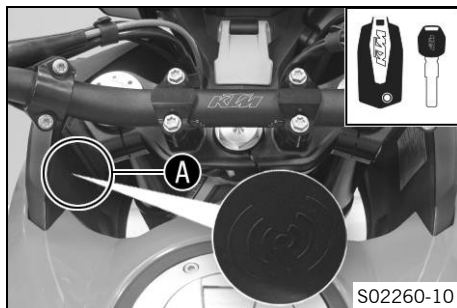

On this vehicle, the ignition/steering lock is replaced by a remote key with transponder (Race-on key (📖 p. 51)).

In order to activate the steering lock, the handlebar must be turned fully to the left.

The steering is locked and unlocked electromechanically via the Race-on button (📖 p. 49).

If the battery voltage of the Race-on key is too low, hold the Race-on key or the black ignition key in area **A** on the motorcycle and repeat starting.



Info

Store the key safely again as soon as the engine has been started.

Possible states

- Ignition off, steering locked – In this operating mode, the ignition circuit is interrupted and the steering locked.
- Ignition off, steering unlocked – In this operating mode, the ignition circuit is interrupted and the steering unlocked.
- Ignition on, steering unlocked – In this operating mode, the ignition circuit is closed and the steering unlocked.

6.15 Immobilizer



The electronic immobilizer secures the vehicle against unauthorized use.

The immobilizer is activated and the engine electronics are locked as soon as the ignition is switched off via the Race-on button (📖 p. 49).

The Race-on indicator lamp ❶ can indicate errors by flashing. If the optional alarm system is installed, the Race-on indicator lamp ❶ flashes when the alarm system is switched on.

6.16 Race-on key

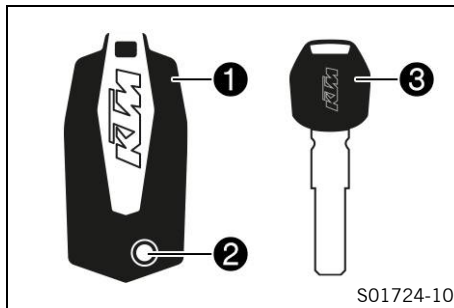

In this vehicle, the Race-on key ❶ performs all the functions of the conventional ignition key.

Press the ❷ button to fold out the key bit. The key bit is only used for unlocking the seat lock and for opening the cases (optional).

The black ignition key ❸ is only intended for situations in which the Race-on key is not available or is not functional.

The black Race-on spare key can be used to start the vehicle if the Race-on key battery voltage is too low and the transponder is not recognized by the vehicle. The black Race-on key can also be used to unlock the seat lock and open the cases (optional).



Info

The key contains electronic components. Always maintain a distance of several centimeters to other devices with electronic components.

A lost key must be deactivated by an authorized KTM workshop to prevent unauthorized persons from operating the vehicle.

The keys supplied are activated when delivered.

A total of up to four keys can be activated from an authorized KTM workshop. The key number must be provided in each case.

6.17 Socket for electrical accessories



Socket **1** for electrical accessories is fitted in front of the upper triple clamp.

It is connected to the permanent positive and is fuse-protected.

Socket for electrical accessories	
Voltage	12 V
Maximum current consumption	10 A

6.18 USB socket

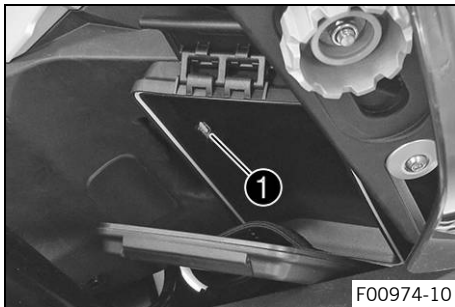

A USB socket **1** is located in the storage compartment for supplying power to external devices. The USB socket is activated when the ignition is switched on.

USB socket	
Voltage	5 V
Maximum current consumption	2.1 A

6.19 Opening the filler cap



Danger

Fire hazard Fuel is highly flammable.

The fuel in the fuel tank expands when warm and can escape if overfilled.

- Do not refuel the vehicle in the vicinity of open flames or lit cigarettes.
- Switch off the engine for refueling.
- Make sure that no fuel is spilled; particularly not on hot parts of the vehicle.
- If any fuel is spilled, wipe it off immediately.
- Observe the specifications for refueling.



Warning

Danger of poisoning Fuel is poisonous and a health hazard.

- Avoid skin, eye and clothing contact with fuel.
- Immediately consult a doctor if you swallow fuel.
- Do not inhale fuel vapors.
- In case of skin contact, rinse the affected area with plenty of water.
- Rinse the eyes thoroughly with water, and consult a doctor in case of fuel contact with the eyes.
- Change your clothing in case of fuel spills on them.
- Keep fuels correctly in a suitable canister, and out of the reach of children.



Warning

Environmental hazard Improper handling of fuel is a danger to the environment.

- Do not allow fuel to enter the groundwater, the soil, or the sewage system.

Condition

The motorcycle is stationary.

The engine is off.

The ignition has been switched on or off for less than 1 minute.

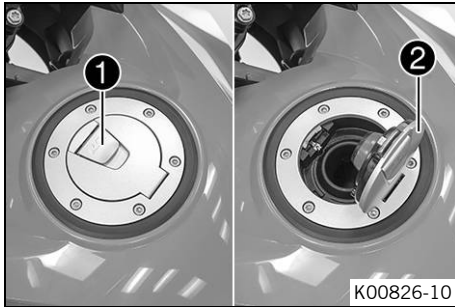

- Fold up cover ① slowly.
- ✓ The filler cap unlocks.
- Fold open filler cap ②.

6.20 Closing the filler cap

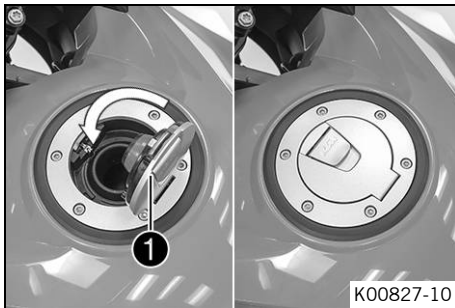

- Fold down the filler cap ① and push it down.
- ✓ The filler cap locks audibly in place.



Warning

Fire hazard Fuel is highly flammable, toxic and a health hazard.

- Check the filler cap is locked correctly after closing.
- Change your clothing in case of fuel spills on them.
- Rinse the affected area immediately with plenty of water in the event of contact with the skin.

6.21 Fuel cocks

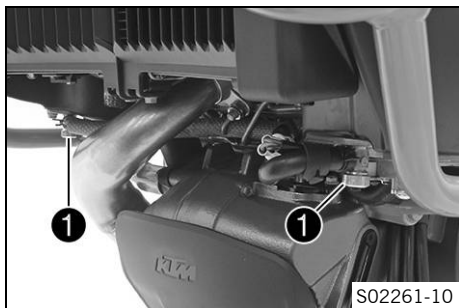

A fuel cock **1** is located on each side of the fuel tank.



Info

The fuel cocks must always be open during operation.
The fuel cocks are only closed to remove the fuel tank.

Possible states

- Fuel cocks are closed – Level equalization cannot take place and the fuel supply to the throttle valve body is shut off.
- Fuel cocks are open – Level equalization can take place and the fuel supply to the throttle valve body is open.

6.22 Opening storage compartment

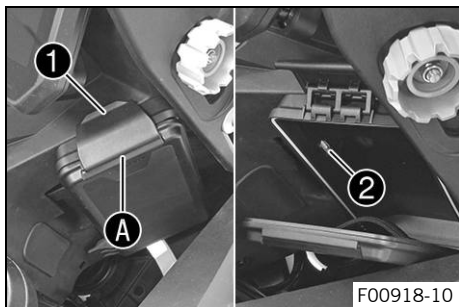

- Lift the lock **1** and detach in area **A**.
- Open storage compartment.



Info

A USB socket **2** (📖 p. 53) is located in the storage compartment for supplying power to external devices.

6.23 Closing storage compartment

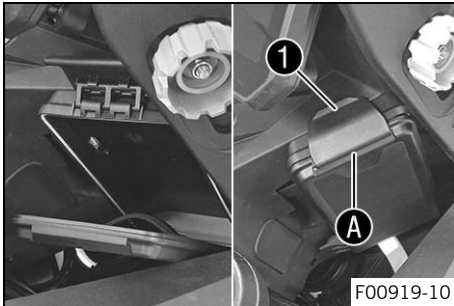

- Close storage compartment.
- Attach lock ① in area ① and press down.



6.24 Seat lock

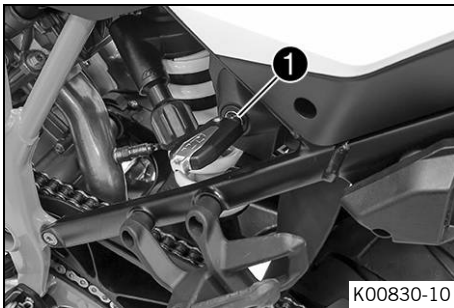

Seat lock ① is located on the left side of the vehicle under the seat.
It can be unlocked using the Race-on key or the black Race-on key.

6 CONTROLS

6.25 Grab handles

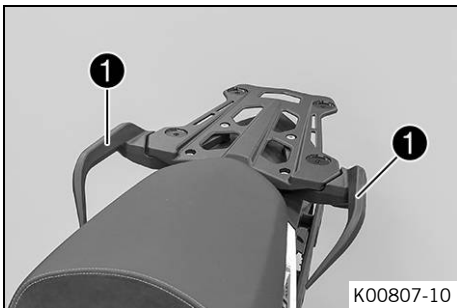

The passenger can hold onto grab handles **1** during the trip.

6.26 Luggage rack plate

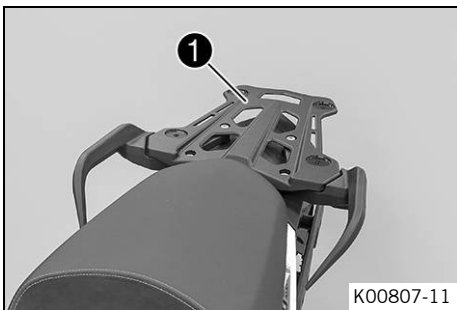

The luggage rack plate **1** is located behind the seat. The base plate of a luggage system (optional) can be attached to the luggage rack plate. The luggage rack plate may not be loaded with more than the specified weight.

Maximum permissible load on luggage rack plate	8 kg (18 lb.)
--	---------------



Info

Note the information provided by the luggage manufacturer.

6.27 Case holders

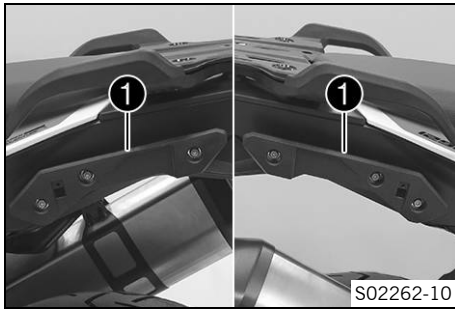

The case holders ① are located on each side of the passenger seat.

A case system (optional) can be attached on the case holders. Use case systems approved and/or recommended by KTM. Observe the specifications in the enclosed **KTM PowerParts** fitting instructions.



Info

The use of other case systems is not recommended. Do not exceed the maximum load of the case holders if using other case systems.

<p>Maximum permissible load of the case holders per side if using other case systems</p>	<p>7 kg (15 lb.)</p>
--	----------------------

6.28 Passenger footrest

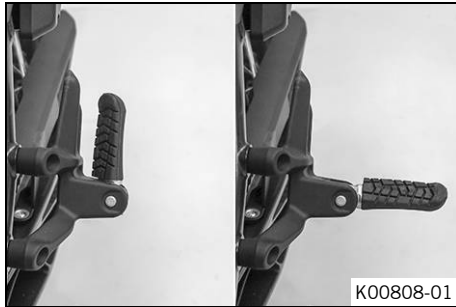

The passenger footrests are foldable.

Possible states

- Passenger footrest folded in – For operation without a passenger.
- Passenger footrest folded out – For operation with a passenger.

6.29 Shift lever

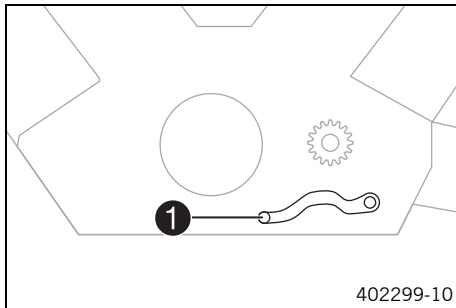

The shift lever **1** is fitted on the left side of the engine.

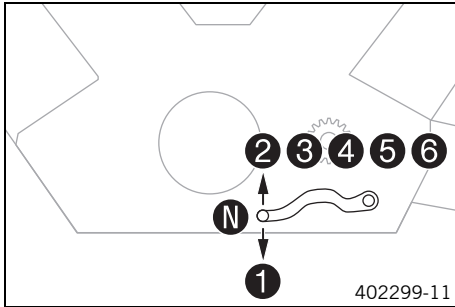

The gear positions can be seen in the figure.
The idle position is between the first and second gears.

6.30 Foot brake lever

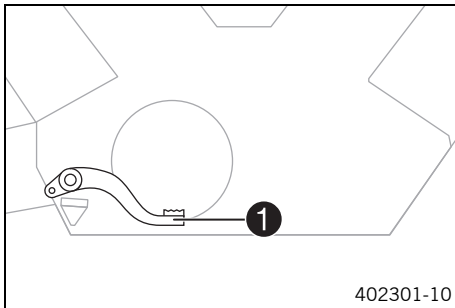

Foot brake lever 1 is located in front of the right footrest.
The rear brake is activated using the foot brake lever.

6.31 Side stand

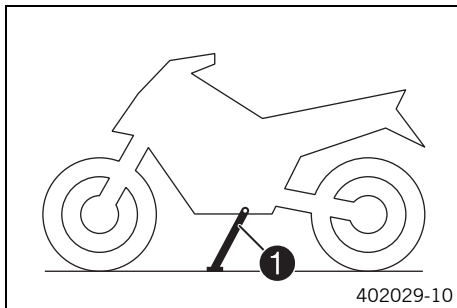

Side stand **1** is located on the left of the vehicle.
The side stand is used for parking the motorcycle.

i Info

The side stand must be folded up during motorcycle use.
The side stand is coupled with the safety starting system.
See the instructions in the "Stopping, parking" chapter.

Possible states

- Side stand folded out – The vehicle can be supported on the side stand. The safety starting system is active.
- Side stand folded in – This position is mandatory when riding the motorcycle. The safety starting system is inactive.

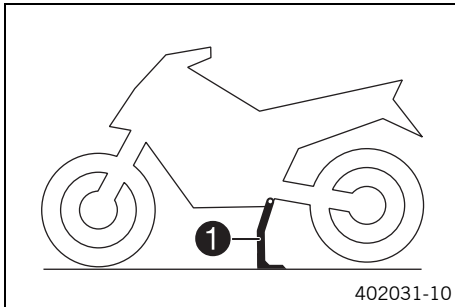
6.32 Center stand

In addition to the side stand, the vehicle is equipped with a center stand **1**.

7 COMBINATION INSTRUMENT

7.1 Combination instrument

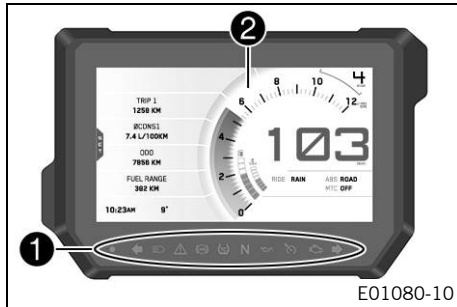

The combination instrument is attached in front of the handlebar. The combination instrument is divided into two function areas.

① indicator lamps (📖 p. 70)

Display ②



Warning

Danger of burns Parts of the combination instrument become very hot in certain situations.

The display becomes particularly hot in the case of external temperatures above 55 °C (131 °F), extended periods in standing position, e.g. at a traffic light, or in direct sunlight.

- Do not touch the combination instrument with bare hands in the situations referred to.
- Where appropriate protective clothing.
- If you have been burned, hold the area affected under lukewarm water immediately.

7.2 Activation and test



Activation

The combination instrument is activated when the ignition is switched on.



Info

The brightness of the displays is controlled by a brightness sensor in the combination instrument.

Test

The welcome text appears on the display and the indicator lamps are briefly activated for a function test.



Info

The malfunction indicator lamp always lights up as long as the engine is not running. If the engine is running and the malfunction indicator lamp lights up, stop (taking care not to endanger yourself or other road users in the process) and contact an authorized KTM workshop.

The oil pressure warning lamp always lights up as long as the engine is not running. If the engine is running and the oil pressure warning lamp lights up, stop immediately (taking care not to endanger yourself or other road users in the process) and switch off the engine.

The ABS indicator lamp and TC indicator lamp light up until a speed of approx. 6 km/h (approx. 4 mph) or more has been reached.

7.3 Day-Night mode



Day mode is shown in a bright color.



Night mode is shown in a dark color.

i Info

The light sensor in the combination instrument measures the brightness of the environment and automatically switches the display to day or night mode. The display is brightened, darkened or switched to the other mode depending on the brightness measured by the light sensor. The display mode cannot be changed manually.

7 COMBINATION INSTRUMENT

7.4 Warning notes

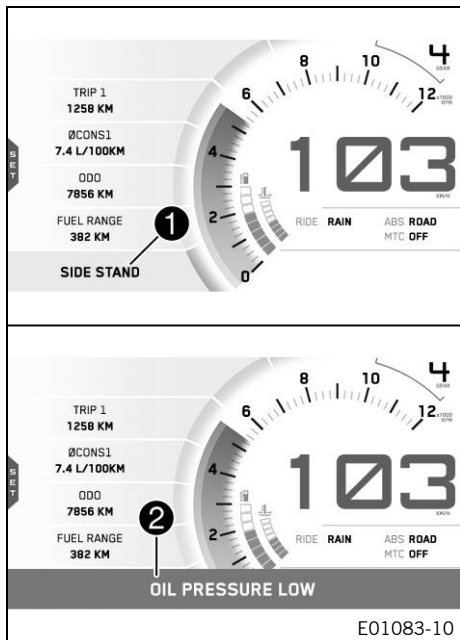

Warning notes appear on the bottom edge of the display, these are marked yellow or red depending on their relevance.

Yellow warning notes ① indicate errors or information which requires prompt intervention or an adjustment to the riding style.

Red warning notes ② indicate errors or information which requires immediate intervention.

i Info

Warning notes are cleared by pressing any button.

All existing warning notes are displayed in the **Warnings** menu until these are no longer active.

7.5 Ice warning

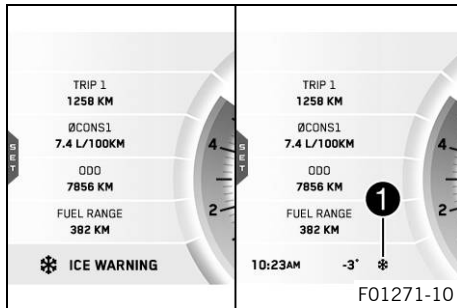

The ice symbol ❄ goes on when there is an increased risk of ice on the roads.

The ice symbol ❄ is shown in area ❶ of the display.

The ice symbol ❄ appears on the display when the ambient temperature drops below the specified value.

Temperature	$\leq 4\text{ }^{\circ}\text{C}$ ($\leq 39\text{ }^{\circ}\text{F}$)
-------------	--

The ice symbol ❄ goes out on the display when the ambient temperature rises back up above the specified value.

Temperature	$\geq 6\text{ }^{\circ}\text{C}$ ($\geq 43\text{ }^{\circ}\text{F}$)
-------------	--

i Info

If the ice symbol ❄ lights up, the warning note **ICE WARNING** also appears.

7 COMBINATION INSTRUMENT

7.6 Indicator lamps



F01267-01

The indicator lamps offer additional information about the operating state of the motorcycle. When the ignition is switched on, all indicator lamps light up briefly.





Info

The malfunction indicator lamp always lights up as long as the engine is not running. If the engine is running and the malfunction indicator lamp lights up, stop (taking care not to endanger yourself or other road users in the process) and contact an authorized KTM workshop.







The oil pressure warning lamp always lights up as long as the engine is not running. If the engine is running and the oil pressure warning lamp lights up, stop immediately (taking care not to endanger yourself or other road users in the process) and switch off the engine.

The ABS indicator lamp and TC indicator lamp light up until a speed of approx. 6 km/h (approx. 4 mph) or more has been reached.

Possible states

	Race-on indicator lamp lights up/flashes yellow/orange/red – Status or error messages relating to Race-on system/alarm system.
	The left turn signal indicator lamp flashes green with a steady rhythmic flash – The left turn signal is switched on.
	The high beam indicator lamp lights up blue – The high beam is switched on.
	The general warning lamp lights up yellow – An operating safety (warning note) message was detected. This is also shown on the display.
	ABS indicator lamp lights up yellow – Status or error messages relating to <u>ABS</u> . The ABS indicator lamp flashes if the ABS mode Offroad is enabled.

7 COMBINATION INSTRUMENT

	TC indicator lamp lights up/flashes yellow – The MTC (📖 p. 295) is not enabled or is currently intervening. The TC indicator lamp also lights up if an error is detected. Contact an authorized KTM workshop. The TC indicator lamp flashes if TC actively engages or if the HHC (📖 p. 162) (optional) is activated.
	The idle indicator lamp lights up green – The transmission is in idle.
	The oil pressure warning lamp lights up red – The oil pressure is too low. Stop immediately, taking care not to endanger yourself or other road users in the process, and switch off the engine.
	The cruise control system indicator lamp lights up yellow – The cruise control system function is switched on, but the speed control is not active.
	The cruise control system indicator lamp lights up green – The cruise control system function is switched on and the speed control is active.
	Malfunction indicator lamp lights up yellow – The OBD has detected an emission- or safety-critical fault.
	The right turn signal indicator lamp flashes green with a steady rhythmic flash – The right turn signal is switched on.

7 COMBINATION INSTRUMENT

7.7 Display

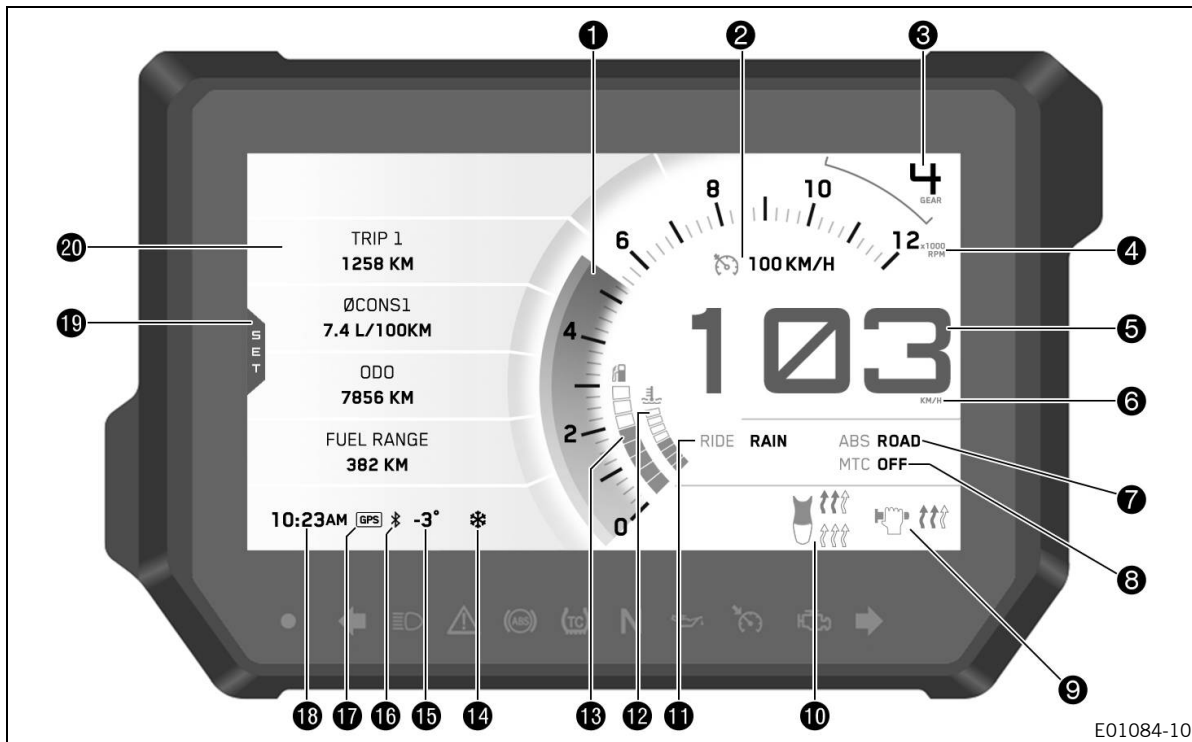

**Info**

The figure shows the standard display of the combination instrument. If the menu is opened, the speed is still displayed.

- ① Speed (📖 p. 76)
- ① Shift warning light (📖 p. 77)
The shift warning light is integrated in the tachometer display.
- ② Cruise control indicator (📖 p. 78)
- ③ Gear display
- ④ Unit for the speed display
- ⑤ Speed (📖 p. 79)
- ⑥ Unit for the speedometer
- ⑦ **ABS** display (📖 p. 79)
- ⑧ **MTC** display (📖 p. 80)
- ⑨ Heated grip (optional) (📖 p. 81)
- ⑩ Seat heater (optional) (📖 p. 81)
- ⑪ **Ride** display (📖 p. 80)
- ⑫ Coolant temperature indicator (📖 p. 82)
- ⑬ Fuel level display (📖 p. 82)
- ⑭ Ice warning (📖 p. 69)
Only shown when there is an increased risk of ice on the roads.
- ⑮ Ambient air temperature indicator (📖 p. 83)

7 COMBINATION INSTRUMENT

- 16 **Bluetooth®** (optional)
- 17 **GPS** (optional)
- 18 Time (📖 p. 84)
- 19 **SET**
Only shown where the menu overview is closed.
- 20 **Favourites** display (📖 p. 84)

7.8 Speed

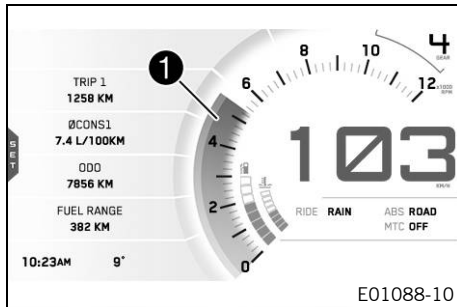

The speed is shown in area 1 of the display.
The speed is measured in revolutions per minute.

7.9 Shift warning light

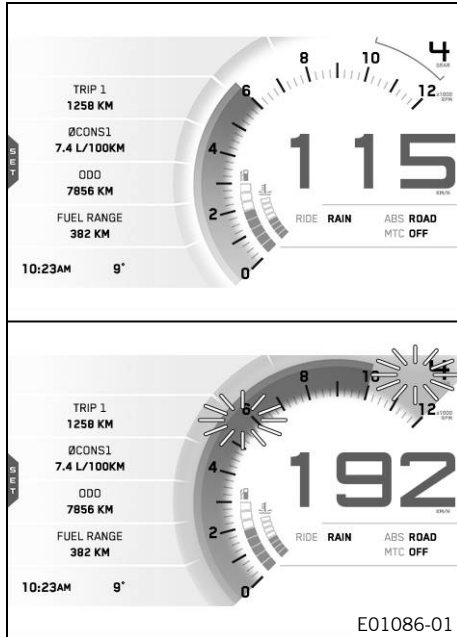

The shift warning light is integrated in the tachometer display. In the **Shift Light** menu, the engine speed for the shift warning light can be set. The shift warning light is always active during the running-in phase (up to 1,000 km / 621 mi). The shift warning light can only be deactivated, and the values for **RPM1** and **RPM2** can only be adjusted after this. The shift warning light lights up red at **RPM1** and flashes red at **RPM2**.

i Info

In sixth-gear, the shift warning light is deactivated when the engine is warm after the first service.

Coolant temperature	$\leq 35\text{ }^{\circ}\text{C}$ ($\leq 95\text{ }^{\circ}\text{F}$)
ODO	< 1,000 km (< 620 mi)
The shift warning light always lights up at	6,500 rpm
Coolant temperature	$> 35\text{ }^{\circ}\text{C}$ ($> 95\text{ }^{\circ}\text{F}$)
ODO	> 1,000 km (> 620 mi)
RPM1 shift warning light	lights up

7 COMBINATION INSTRUMENT

RPM2 shift warning light	flashes
-----------------------------	---------

7.10 Cruise control indicator

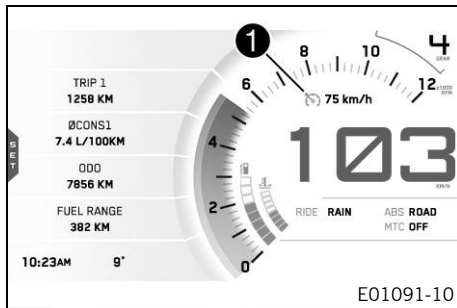

The operating state and active cruise control are shown in the **1** area of the display.

Cruise control is operated using the cruise control tip switch (📖 p. 41).

7.11 Speed

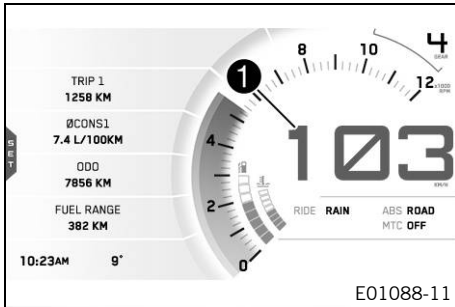

The speed is shown in area ❶ of the display.
The unit of speed can be configured in the **Distance** menu.
Speed is shown in kilometers per hour **km/h** or in miles per hour **mph**.

7.12 ABS display

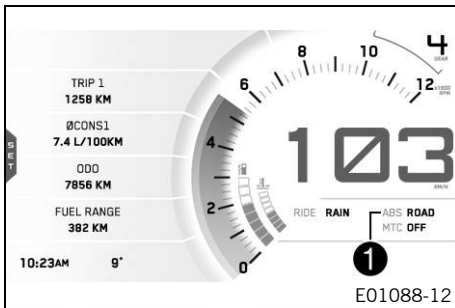

The ABS mode setting is shown in the ❶ area of the display.
The **ABS** can be configured in the **ABS** menu.

7 COMBINATION INSTRUMENT

7.13 MTC display

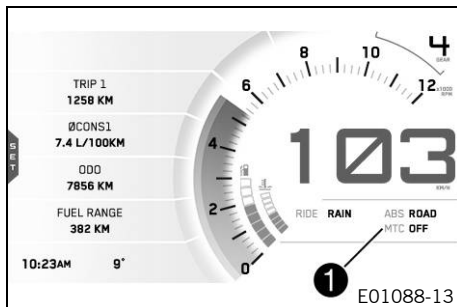

The **1** area of the display indicates whether **MTC** the system is switched on or off.
The motorcycle traction control can be switched on or off in the **MTC** menu.

7.14 Ride display

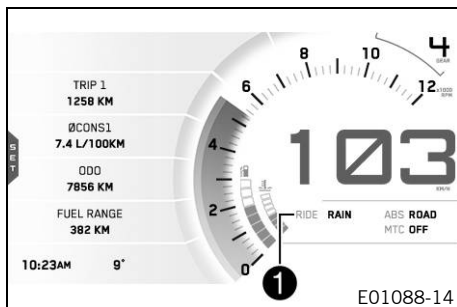

The **Ride Mode** setting is shown in area **1** of the display.
The drive mode can be configured in the **Ride Mode** menu.

7.15 Heated grip (optional)

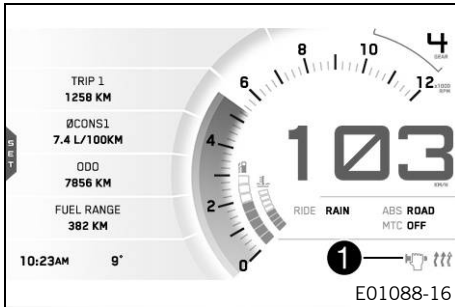

When the heated grip is switched on, the **Heated Grips** symbol appears in the **1** area of the display. The heated grip can be configured in the **Heated Grips** menu.

7.16 Seat heater (optional)

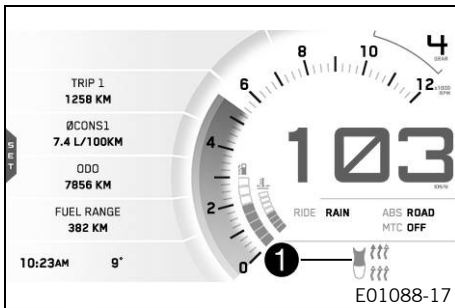

When the seat heating is switched on, the **Heated Seat** symbol appears in the **1** area of the display. The seat heating can be configured in the **Heated Seat** menu.

i Info

The heating level for the passenger seat heating can be controlled by a switch next to the right grab handle.

7 COMBINATION INSTRUMENT

7.17 Coolant temperature indicator

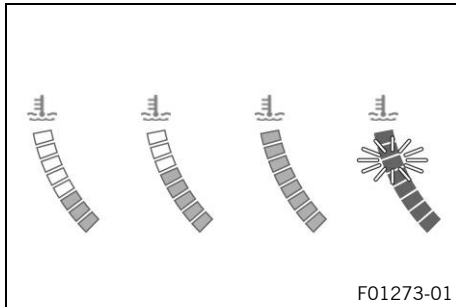

The coolant temperature indicator consists of bars. The more bars that light up, the hotter the coolant.



Info

When all bars flash, the following warning note **ENGINE TEMP HIGH** appears.

Possible states

- The engine is cold – Up to three bars light up.
- Engine warm – Four bars light up.
- Engine hot – Five to eight bars light up.
- Engine very hot – all eight bars flash red.

7.18 Fuel level display

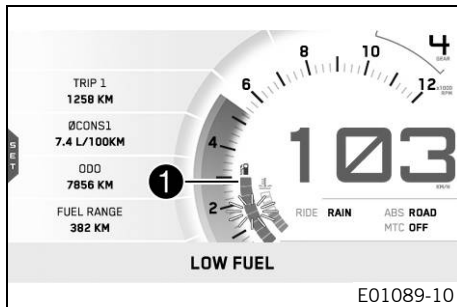

The fuel tank contents are shown in area ❶ of the display. The fuel level indicator consists of bars. The more bars are lit, the more fuel is in the fuel tank.

i Info

If the fuel level is getting low, all eight segments flash red and the following warning note also appears **LOW FUEL**. The fuel level is displayed with a slight delay to prevent the indicator from constantly moving while riding. The fuel level display is not updated while the side stand is folded out or the emergency off switch is switched off. Once the side stand is folded up and emergency OFF switch is switched on, the fuel level display is next updated after 2 minutes. The fuel level display flashes if the combination instrument does not receive a signal from the fuel level sensor.

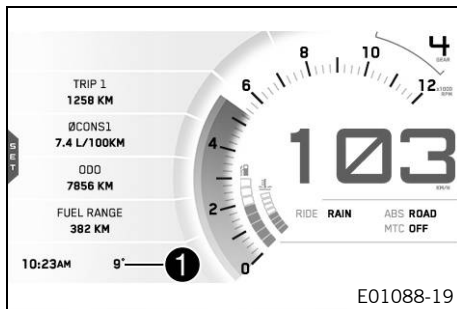
7.19 Ambient air temperature indicator

The ambient air temperature is displayed in the ❶ area. The unit of ambient air temperature can be configured in the **Temperature** menu. The ambient air temperature is displayed in **°C** or **°F**.

7 COMBINATION INSTRUMENT

7.20 Time

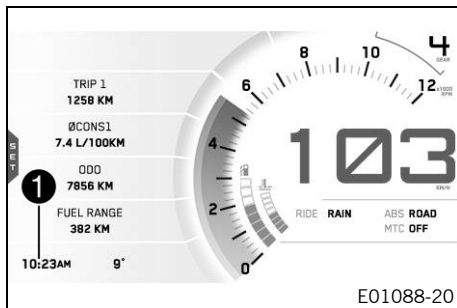

The time is shown in area ❶ of the display.
The time is displayed in 24 hour format in all languages except for EN-US. The time is displayed in 12 hour format if the language is set to EN-US.
The time can be configured in the **Time/Date** menu.



Info

The time must be reset after the battery was disconnected or the fuse was removed.

7.21 Favourites display

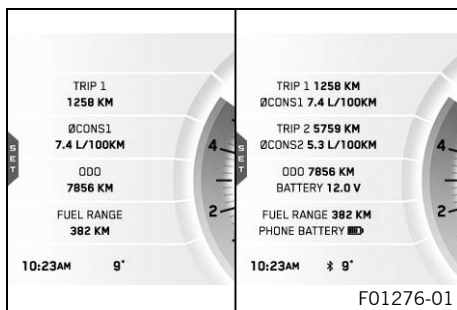

Up to eight items of information are shown in the **Favourites** display.

The **Favourites** display can be freely configured in the **Favourites** menu.



Info

One to four items of information selected are displayed on two lines. Five to eight items of information selected are displayed on a single line.

7.22 Quick Selector 1 display

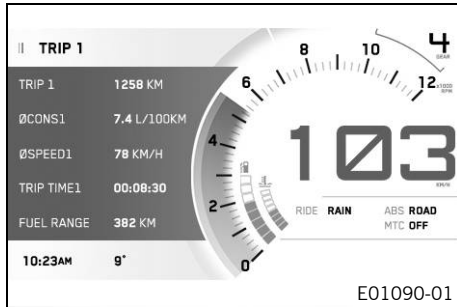

When the menu is closed, the **Quick Selector 1** menu is opened by pressing the **UP** button.
Press the **BACK** button to close **Quick Selector 1**.



Info

The **Quick Selector 1** can be configured in the **Quick Selector 1** menu. Any information can be selected.

7.23 Quick Selector 2 display

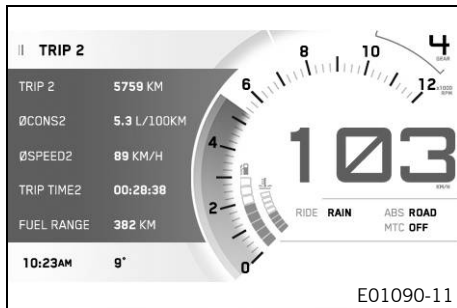

When the menu is closed, the **Quick Selector 2** menu is opened by pressing the **DOWN** button.
Press the **BACK** button to close **Quick Selector 2**.



Info

The **Quick Selector 2** can be configured in the **Quick Selector 2** menu. Any information can be selected.

7.24 Navigation-Display (optional)

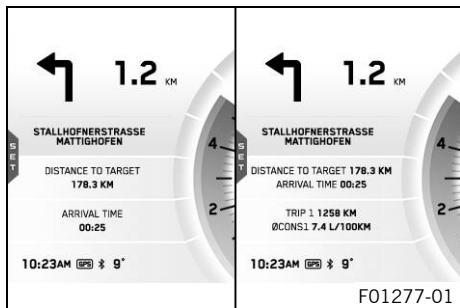

The **Navigation** display appears when the navigation function is active.

The **Navigation** display shows the direction arrow, the distance to the next waypoint, the road name as well as up to four sets of information.

The **Navigation** display can be freely configured in the **Navigation Info Screen** menu.



Info

One to two sets of information selected are displayed on two lines. Three to four sets of information selected are displayed on one line.

7.25 Menu

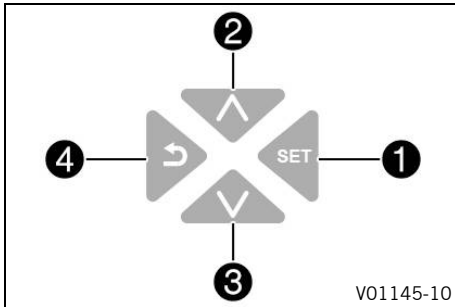

i Info

Press the **SET** button **1** in the standard display to open the menu.

Navigate through the menu using the **UP** button **2** or the **DOWN** button **3**.

Press the **BACK** button **4** to close the current menu or the menu overview.

If no button of the left combination switch is pressed when the menu is open, the menu closes automatically after about 20 seconds. Pressing the **SET** button again calls up the menu last opened.

7.25.1 KTM MY RIDE (optional)

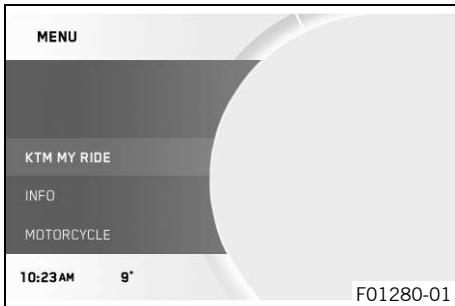

Condition

- The motorcycle is stationary.
- Function **KTM MY RIDE** (optional) activated.
 - Press the **SET** button when the menu is closed.
 - Press the **UP** or **DOWN** button until **KTM MY RIDE** is marked. Press the **SET** button to open the menu.

In **KTM MY RIDE** an appropriate cellphone or headset can be paired with the combination instrument via **Bluetooth®** and the navigation function can be configured.



Info

Not every cellphone and headset is suitable for pairing with the combination instrument.

The standard **Bluetooth**® 2.1 must be supported.

7.25.2 Audio (optional)

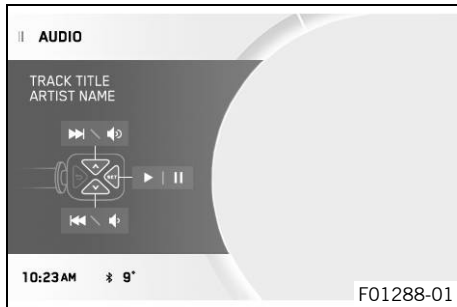

Condition

- Function **KTM MY RIDE** (optional) activated.
- Function **Wireless Interface** (optional) activated.
- The combination instrument is connected to a suitable cellphone.
- The combination instrument is connected to a suitable headset.
 - Press the **SET** button when the menu is closed.
 - Press the **UP** or **DOWN** button until **KTM MY RIDE** is marked. Press the **SET** button to open the menu.



Warning

Danger of accidents Headphone volume which is too high distracts attention from traffic activity.

- Always select headphone volume which is low enough for you to still clearly hear acoustic signals.

- Press the **UP** or **DOWN** button until **Audio** is marked. Press the **SET** button to open the menu.
 - Press and hold the **UP** button to increase the audio volume.
 - Press and hold the **DOWN** button to reduce the audio volume.
 - Press the **UP** button briefly to change to the next audio track.
 - Briefly pressing the **DOWN** button twice changes to the previous audio title or plays the current audio title, depending on the cellphone model.
 - Press the **SET** button to play or pause the audio track.
-



Tip

With some cellphones, the audio player needs to be started before playback is possible.

The **Audio** function can be added to **Quick Selector 1** or **Quick Selector 2** for easier operation.

7.25.3 Navigation (optional)

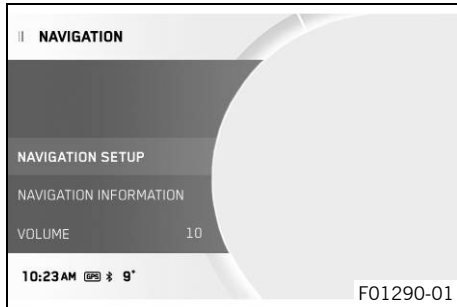

Condition

- Function **KTM MY RIDE** (optional) activated.
- The **KTM MY RIDE** app (optional) is installed and opened on a suitable cellphone (Android devices Version 6.0 and higher, iOS devices Version 10 and higher).
- The combination instrument is connected to a suitable cellphone.
- The GPS function is activated on the connected cellphone.
- For voice navigation: The combination instrument is connected to a suitable headset and an appropriate language package has been downloaded in the **KTM MY RIDE** app.
 - Press the **SET** button when the menu is closed.
 - Press the **UP** or **DOWN** button until **KTM MY RIDE** is marked. Press the **SET** button to open the menu.
 - Press the **UP** or **DOWN** button until **Navigation** is marked. Press the **SET** button to open the menu.

The **Navigation** menu allows various settings to be made and general information on the navigation to be called up.

i Info

The **Audio** function can be used with the navigation function at the same time.

An incoming call is visualized in a small window at the top of the combination instrument display when the navigation function is active. You cannot navigate in the **Navigation** menu during an active phone conversation.

When the navigation function is switched on and the device is connected, the **GPS** symbol appears in the display of the combination instrument.

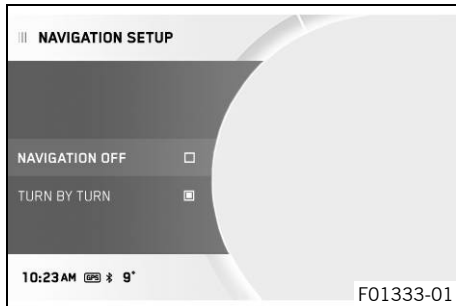
7.25.4 Navigation setup (optional)**Condition**

- Function **KTM MY RIDE** activated (optional).
 - The **KTM MY RIDE** app (optional) is installed and opened on a suitable cellphone (Android devices Version 6.0 and higher, iOS devices Version 10 and higher).
 - The combination instrument is connected to a suitable cellphone.
 - The GPS function is activated on the connected cellphone.
- Press the **SET** button when the menu is closed.
 - Press the **UP** or **DOWN** button until **KTM MY RIDE** is marked. Press the **SET** button to open the menu.

- Press the **UP** or **DOWN** button until **Navigation** is marked. Press the **SET** button to open the menu.
- Press the **UP** or **DOWN** button until **Navigation Setup** is marked. Press the **SET** button to open the menu.
- Press the **UP**- or **DOWN** button until the desired menu item **Navigation Off** or **Turn by Turn** is marked. Press the **SET** button to switch the submenu item on or off.



Info

The visual navigation can be switched on or off with the **Navigation Off**. An activated voice navigation remains switched on.

The visual navigation can be changed to direction arrows with **Turn by Turn**.

Navigation mode can be set in the **Navigation Setup** submenu.

7.25.5 Navigation information (optional)

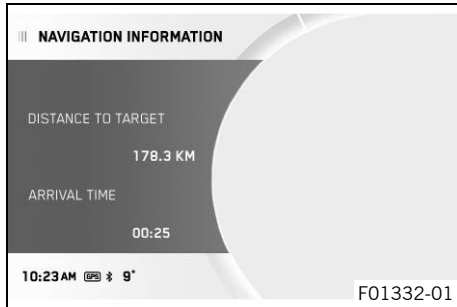

Condition

- Function **KTM MY RIDE** (optional) activated.
 - The **KTM MY RIDE** app (optional) is installed and opened on a suitable cellphone (Android devices Version 6.0 and higher, iOS devices Version 10 and higher).
 - The combination instrument is connected to a suitable cellphone.
 - The GPS function is activated on the connected cellphone.
- Press the **SET** button when the menu is closed.
 - Press the **UP** or **DOWN** button until **KTM MY RIDE** is marked. Press the **SET** button to open the menu.
 - Press the **UP** or **DOWN** button until **Navigation** is marked. Press the **SET** button to open the menu.
 - Press the **UP** or **DOWN** button until **Navigation Information** is marked. Press the **SET** button to open the menu.



Info

Distance to Target shows the distance to the destination.
Arrival Time shows the arrival time of the cellphone.

Information on the current navigation can be viewed in the **Navigation Information** submenu.

7.25.6 Volume (optional)

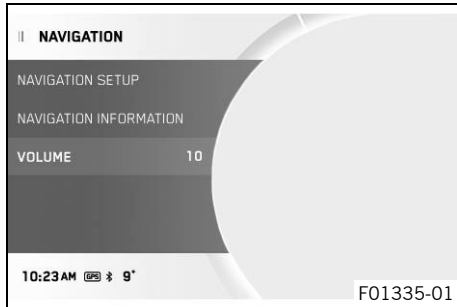

Condition

- Function **KTM MY RIDE** (optional) activated.
- The **KTM MY RIDE** app (optional) is installed and opened on a suitable cellphone (Android devices Version 6.0 and higher, iOS devices Version 10 and higher).
- The combination instrument is connected to a suitable cellphone.
- The GPS function is activated on the connected cellphone.
- For voice navigation: The combination instrument is connected to a suitable headset and an appropriate language package has been downloaded in the **KTM MY RIDE** app.
 - Press the **SET** button when the menu is closed.
 - Press the **UP** or **DOWN** button until **KTM MY RIDE** is marked. Press the **SET** button to open the menu.
 - Press the **UP** or **DOWN** button until **Navigation** is marked. Press the **SET** button to open the menu.



Warning

Danger of accidents Headphone volume which is too high distracts attention from traffic activity.

- Always select headphone volume which is low enough for you to still clearly hear acoustic signals.

- Press the **UP** or **DOWN** button until **Volume** is marked. Press the **SET** button to open the menu.
 - Press and hold the **UP** button to increase the audio volume.
 - Press and hold the **DOWN** button to reduce the audio volume.
- The volume of the navigation can be set in the **Volume** submenu.

7.25.7 Setup (optional)

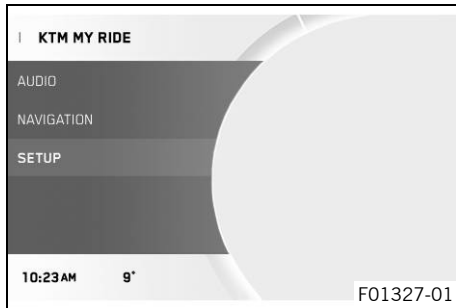

Condition

- The motorcycle is stationary.
 - Function **KTM MY RIDE** (optional) activated.
- Press the **SET** button when the menu is closed.
 - Press the **UP** or **DOWN** button until **KTM MY RIDE** is marked. Press the **SET** button to open the menu.
 - Press the **UP** or **DOWN** button until **Setup** is marked. Press the **SET** button to open the menu.

Setup allows you to configure **Wireless Interface** via which the **Bluetooth** menu can be activated or deactivated.



Info

The **Bluetooth®** function can only be used in conjunction with **KTM MY RIDE** (optional).
When the **Bluetooth®** function is switched on and the device is connected, the **Bluetooth®** symbol appears in the display of the combination instrument.
Not every cellphone and headset is suitable for pairing with the combination instrument.

7.25.8 Bluetooth (optional)

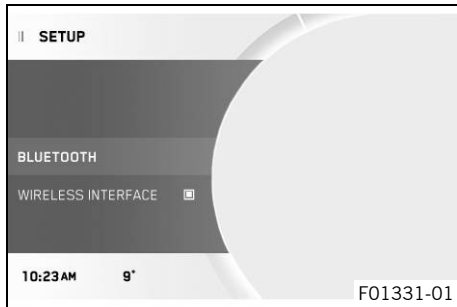

Condition

- The motorcycle is stationary.
- Function **KTM MY RIDE** (optional) activated.
- Function **Wireless Interface** (optional) activated.
- Press the **UP** or **DOWN** button until **Setup** is marked. Press the **SET** button to open the menu.
- Press the **UP** or **DOWN** button until **Bluetooth** is marked. Press the **SET** button to open the menu.

In **Bluetooth** an appropriate cellphone or headset can be paired with the combination instrument via **Bluetooth®**.

**Info**

The **Bluetooth®** function can only be used in conjunction with **KTM MY RIDE** (optional).
 When the **Bluetooth®** function is switched on and the device is connected, the **Bluetooth®** symbol appears in the display of the combination instrument.
 Not every cellphone and headset is suitable for pairing with the combination instrument.

7.25.9 Phone (optional)

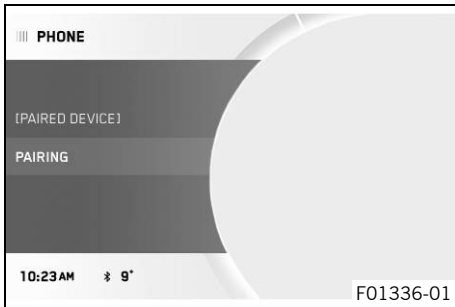
**Condition**

- The motorcycle is stationary.
 - Function **KTM MY RIDE** (optional) activated.
 - Function **Wireless Interface** (optional) activated.
 - The **Bluetooth®** function should also be activated in the device to be paired.
- Press the **UP** or **DOWN** button until **Setup** is marked. Press the **SET** button to open the menu.
 - Press the **UP** or **DOWN** button until **Bluetooth** is marked. Press the **SET** button to open the menu.
 - Press the **UP** or **DOWN** button until the desired menu item **Phone** is marked. Press the **SET** button to open the menu.



Info

Two cellphones can never be paired simultaneously with the combination instrument.

- Press the **SET** button again to confirm the **Pairing** submenu item.
 - A message appears on the combination instrument indicating that this is now ready for pairing. The pairing is completed successfully by confirming the **Passkey** on the cellphone and on the combination instrument.
-



Info

Once the pairing is completed, the registered trademark of the paired cellphone is displayed in the **Phone** menu. Press the **UP** or **DOWN** button until paired device is marked on the display. The paired device can be deleted by pressing the **SET** button. Not every cellphone is suitable for pairing with the combination instrument.

- Move the device already paired into the range of the combination instrument while the **Bluetooth®** function is active.
 - ✓ The device is automatically paired with the combination instrument.
-

- ✘ If the device is not automatically paired with the combination instrument after approx. 30 seconds:
 - Restart combination instrument or **Pairing** repeat procedure.

A suitable cellphone can be paired with the combination instrument in the **Phone** submenu.

7.25.10 Headset Rider (optional)

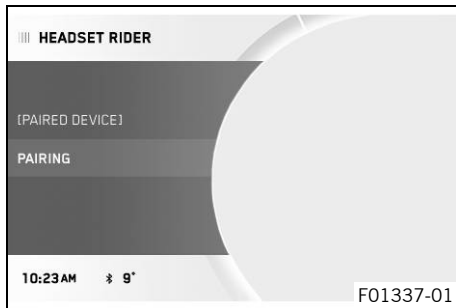

Condition

- The motorcycle is stationary.
- Function **KTM MY RIDE** (optional) activated.
- Function **Wireless Interface** (optional) activated.
- The **Bluetooth®** function should also be activated in the device to be paired.
 - Press the **UP** or **DOWN** button until **Setup** is marked. Press the **SET** button to open the menu.
 - Press the **UP** or **DOWN** button until **Bluetooth** is marked. Press the **SET** button to open the menu.
 - Press the **UP** or **DOWN** button until **Headset Rider** is marked. Press the **SET** button to open the menu.
 - Press the **SET** button again to confirm the **Pairing** submenu item.
- The registered trademark of the rider headset appears on the combination instrument. Press the **SET** button to select the

device. Press the **SET** button again to confirm the **Confirm** sub-menu item. The pairing of a rider headset with the combination instrument is now completed at this point.



Info

Once the pairing is completed, the registered trademark of the paired headset is displayed in the **Headset Rider** menu.

Press the **UP** or **DOWN** button until paired device is marked on the display. The paired device can be deleted by pressing the **SET** button.

Not every headset is suitable for pairing with the combination instrument.

-
- Move the device already paired into the range of the combination instrument while the **Bluetooth®** function is active.
 - ✓ The device is automatically paired with the combination instrument.
 - ✗ If the device is not automatically paired with the combination instrument after approx. 30 seconds:
 - Restart combination instrument or **Pairing** repeat procedure.

A suitable rider headset can be paired with the combination instrument in the **Headset Rider** submenu.

7.25.11 Headset Pass. (optional)

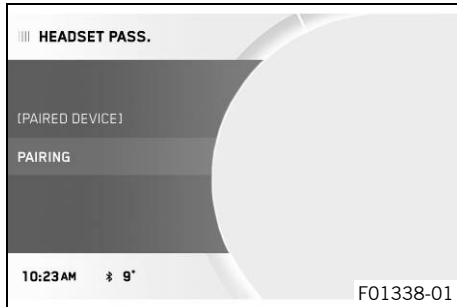

Condition

- The motorcycle is stationary.
- Function **KTM MY RIDE** (optional) activated.
- Function **Wireless Interface** (optional) activated.
- The **Bluetooth**® function should also be activated in the device to be paired.
 - Press the **UP** or **DOWN** button until **Setup** is marked. Press the **SET** button to open the menu.
 - Press the **UP** or **DOWN** button until **Bluetooth** is marked. Press the **SET** button to open the menu.
 - Press the **UP** or **DOWN** button until **Headset Pass.** is marked. Press the **SET** button to open the menu.
 - Press the **SET** button again to confirm the **Pairing** submenu item.
 - The registered trademark of the passenger headset appears on the combination instrument. Press the **SET** button to select the device. Press the **SET** button again to confirm the **Confirm** submenu item. The pairing of a passenger headset with the combination instrument is now completed at this point.



Info

Once the pairing is completed, the registered trademark of the paired headset is displayed in the **Headset Pass.** menu.

Press the **UP** or **DOWN** button until paired device is marked on the display. The paired device can be deleted by pressing the **SET** button.

Not every headset is suitable for pairing with the combination instrument.

-
- Move the device already paired into the range of the combination instrument while the **Bluetooth®** function is active.
 - ✓ The device is automatically paired with the combination instrument.
 - ✗ If the device is not automatically paired with the combination instrument after approx. 30 seconds:
 - Restart combination instrument or **Pairing** repeat procedure.

A suitable passenger headset can be paired with the combination instrument in the **Headset Pass.** submenu.

7.25.12 Wireless Interface

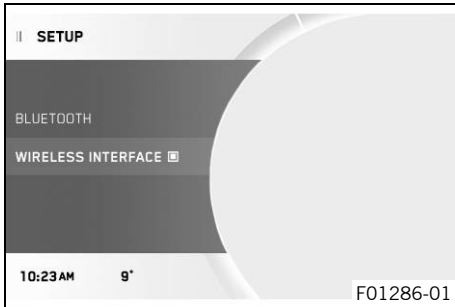

Condition

- The motorcycle is stationary.
- Function **KTM MY RIDE** (optional) activated.
 - Press the **SET** button when the menu is closed.
 - Press the **UP** or **DOWN** button until **KTM MY RIDE** is marked. Press the **SET** button to open the menu.
 - Press the **UP** or **DOWN** button until **Setup** is marked. Press the **SET** button to open the menu.
 - Press the **UP** or **DOWN** button until **Wireless Interface** is marked. Switch the **Wireless Interface** on or off by pressing the **SET** button.

Wireless Interface allows the **Bluetooth®** menu to be activated or deactivated.

Info

The **Bluetooth®** function can only be used in conjunction with **KTM MY RIDE** (optional). When the **Bluetooth®** function is switched on and the device is connected, the **Bluetooth®** symbol appears in the display of the combination instrument. Not every cellphone and headset is suitable for pairing with the combination instrument.

7 COMBINATION INSTRUMENT

7.25.13 Telephony (optional)

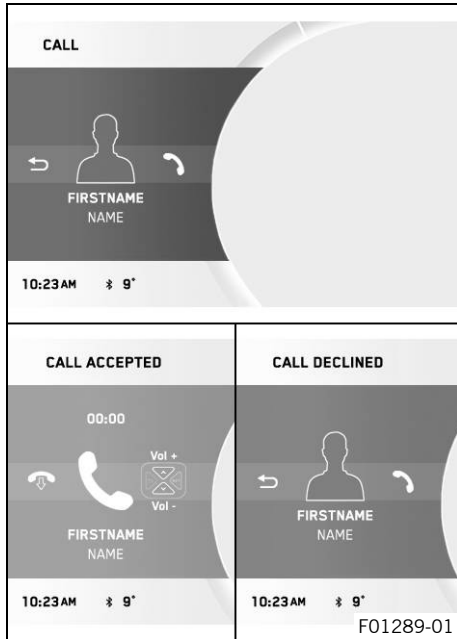

Condition

- Function **KTM MY RIDE** (optional) activated.
- Function **Wireless Interface** (optional) activated.
- The combination instrument is connected to a suitable cell-phone.
- The combination instrument is connected to a suitable head-set.



Warning

Danger of accidents Headphone volume which is too high distracts attention from traffic activity.

- Always select headphone volume which is low enough for you to still clearly hear acoustic signals.

- Press the **SET** button to accept an incoming call.
- Press and hold down the **BACK** button to reject an incoming call.
- Press and hold the **UP** button to increase the audio volume.
- Press and hold the **DOWN** button to reduce the audio volume.



Info

The call duration and contact are displayed. Depending on the cellphone settings, the contact is displayed with a picture and a name.

An incoming call is visualized in a small window at the top of the combination instrument display when the navigation function is active.

7.25.14 Info

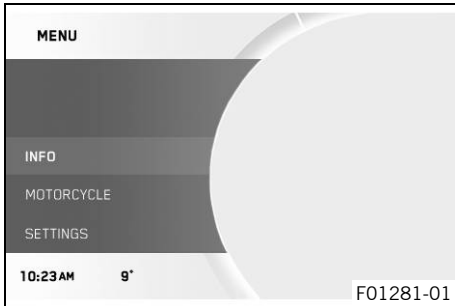

- Press the **SET** button when the menu is closed.
- Press the **UP** or **DOWN** button until **Info** is marked. Press the **SET** button to open the menu.

General information can be accessed in **Info**.

7 COMBINATION INSTRUMENT

7.25.15 Trip 1

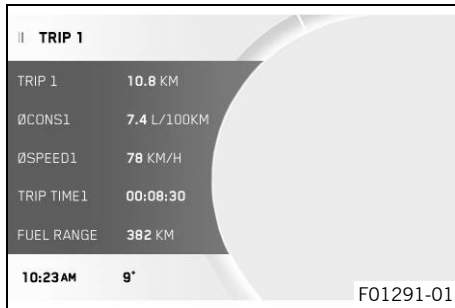

- Press the **SET** button when the menu is closed.
- Press the **UP** or **DOWN** button until **Info** is marked. Press the **SET** button to open the menu.
- Press the **UP** or **DOWN** button until **Trip 1** is marked. Press the **SET** button to open the menu.

Trip 1 shows the distance since the last reset, such as between two refueling stops. **Trip 1** is running and counts up to **9999**.

ØCons1 indicates the average fuel consumption based on **Trip 1**.

ØSpeed1 indicates the average speed based on **Trip 1** and **Trip Time1**.

Trip Time1 shows the journey time on the basis of **Trip 1** and runs as soon as a speed signal is received.

Fuel Range indicates the possible distance you can cover with the fuel reserve.

Press and hold the **SET** button for 3 - 5 seconds.

All entries in the **Trip 1** menu are reset.

7.25.16 Trip 2

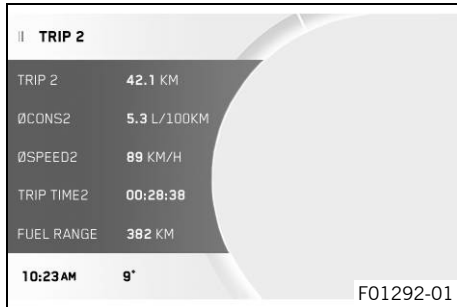

- Press the **SET** button when the menu is closed.
- Press the **UP** or **DOWN** button until **Info** is marked. Press the **SET** button to open the menu.
- Press the **UP** or **DOWN** button until **Trip 2** is marked. Press the **SET** button to open the menu.

Trip 2 shows the distance since the last reset, such as between two refueling stops. **Trip 2** is running and counts up to **9999**.

ØCons2 indicates the average fuel consumption based on **Trip 2**.

ØSpeed2 indicates the average speed based on **Trip 2** and **Trip Time2**.

Trip Time2 shows the journey time on the basis of **Trip 2** and runs as soon as a speed signal is received.

Fuel Range indicates the possible distance you can cover with the fuel reserve.

Press and hold the **SET** button for 3 - 5 seconds.

All entries in the **Trip 2** menu are reset.

7 COMBINATION INSTRUMENT

7.25.17 General Info

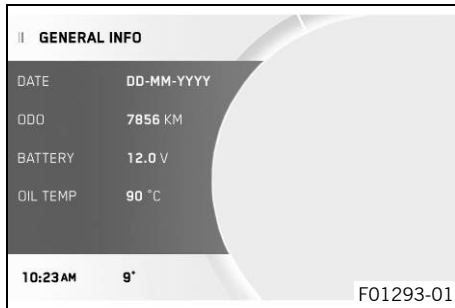

- Press the **SET** button when the menu is closed.
- Press the **UP** or **DOWN** button until **Info** is marked. Press the **SET** button to open the menu.
- Press the **UP** or **DOWN** button until **General Info** is marked. Press the **SET** button to open the menu.

Date shows the date.

ODO shows the total distance covered.

Battery indicates the battery voltage.

Oil Temperature indicates the engine oil temperature.

7.25.18 TPMS

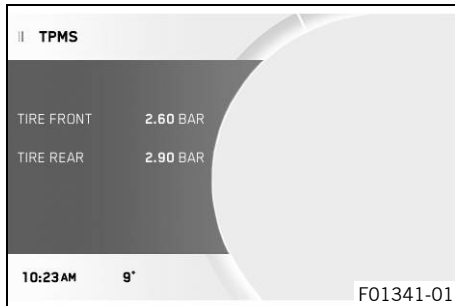

Condition

- Model with **TPMS**.
- Press the **SET** button when the menu is closed.
- Press the **UP** or **DOWN** button until **Info** is marked. Press the **SET** button to open the menu.



Warning

Danger of accidents The tire pressure control system does not eliminate the necessity to check the tires before going on a ride.

To avoid false alarms, the tire pressure values are evaluated over a period of several minutes.

- Check the tire pressure before every ride.
- Correct the tire pressure if the tire pressure deviates from the specified value.
- Even if the tire pressure values are correct, stop the vehicle immediately if its behavior indicates a pressure loss in the tires.

- Press the **UP** or **DOWN** button until **TPMS** is marked. Press the **SET** button to open the menu.

Guideline

Tire air pressure, solo/with passenger/full payload	
front: with cold tires	2.6 bar (38 psi)
rear: with cold tires	2.9 bar (42 psi)

The **TPMS** menu displays the tire air pressure of the front and rear tires.

TIRE FRONT indicates the tire air pressure at the front.

TIRE REAR indicates the tire air pressure at the rear.

7 COMBINATION INSTRUMENT

7.25.19 Warnings

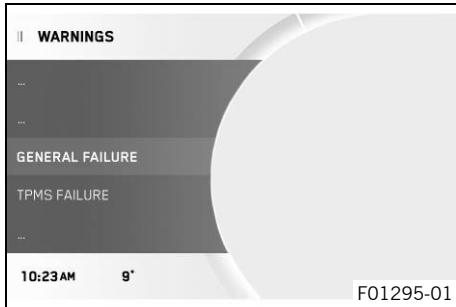

Condition

- Message or warning is present.
 - Press the **SET** button when the menu is closed.
 - Press the **UP** or **DOWN** button until **Info** is marked. Press the **SET** button to open the menu.
 - Press the **UP** or **DOWN** button until **Warnings** is marked. Press the **SET** button to open the menu.
 - Use the **UP** or **DOWN** button to navigate through the warnings.

In the **Warnings** menu, all warnings that have occurred are displayed and stored.

7.25.20 Service

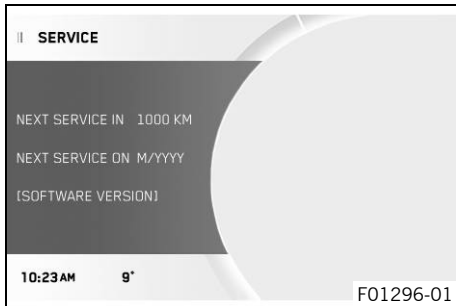

Condition

- The motorcycle is stationary.
 - Press the **SET** button when the menu is closed.
 - Press the **UP** or **DOWN** button until **Info** is marked. Press the **SET** button to open the menu.
 - Press the **UP** or **DOWN** button until **Service** is marked. Press the **SET** button to open the menu.

The next service due is shown in the **Service** menu.

7.25.21 Extra Functions

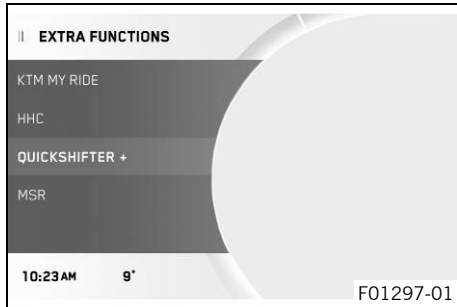

Condition

- The motorcycle is stationary.
- Motorcycle with optional supplementary function.
 - Press the **SET** button when the menu is closed.
 - Press the **UP** or **DOWN** button until **Info** is marked. Press the **SET** button to open the menu.
 - Press the **UP** or **DOWN** button until **Extra Functions** is marked. Press the **SET** button to open the menu.
 - Use the **UP** or **DOWN** button to navigate through the extra functions.

The optional extra functions are listed in **Extra Functions**.



Info

The current **KTM PowerParts** and the available software for your vehicle can be found on the KTM website.

7 COMBINATION INSTRUMENT

7.25.22 Motorcycle

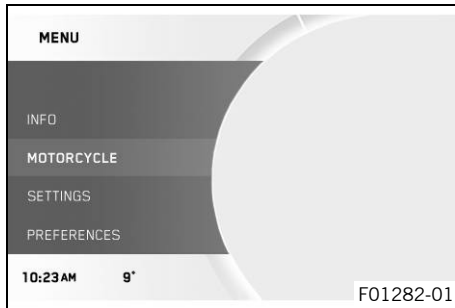

Condition

- The motorcycle is stationary.
 - Press the **SET** button when the menu is closed.
 - Press the **UP** or **DOWN** button until **Motorcycle** is marked. Press the **SET** button to open the menu.

The vehicle drive mode can be configured in **Motorcycle**.

7.25.23 Heated Grips (optional)

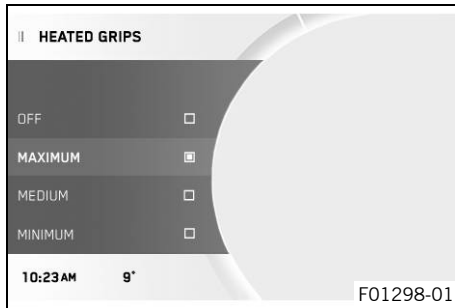

Condition

- The motorcycle is stationary.
- Menu **Heated Grips** activated.
 - Press the **SET** button when the menu is closed.
 - Press the **UP** or **DOWN** button until **Motorcycle** is marked. Press the **SET** button to open the menu.
 - Press the **UP** or **DOWN** button until **Heated Grips** is marked. Press the **SET** button to open the menu.
 - Activate the menu item using the **UP** or **DOWN** button.
 - Press the **SET** button to select the heating level or to switch the heated grip on or off.

7.25.24 Heated Seat (optional)

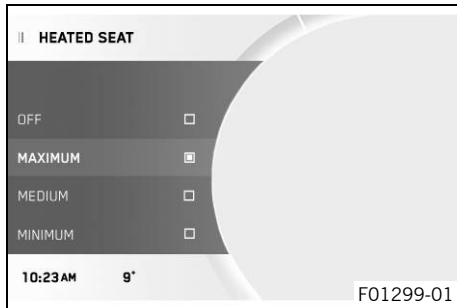
**Condition**

- The motorcycle is stationary.
 - Menu **Heated Seat Ride** activated.
 - Menu **Heated Seat Pas** activated.
- Press the **SET** button when the menu is closed.
 - Press the **UP** or **DOWN** button until **Motorcycle** is marked. Press the **SET** button to open the menu.
 - Press the **UP** or **DOWN** button until **Heated Seat** is marked. Press the **SET** button to open the menu.
 - Activate the menu item using the **UP** or **DOWN** button.
 - Press the **SET** button to select the heating level or to switch the seat heating on or off.

**Info**

The heating level for the passenger seat heating is selected using the switch next to the right grab handle.

7.25.25 Ride Mode

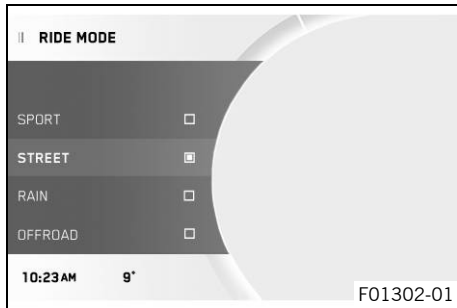

Condition

- Emergency OFF switch/electric starter button on (middle position) – This position is required for operation; the ignition circuit is closed. (📖 p. 48)
- Cruise control system function deactivated
 - Press the **SET** button when the menu is closed.
 - Press the **UP** or **DOWN** button until **Motorcycle** is marked. Press the **SET** button to open the menu.
 - Press the **UP** or **DOWN** button until **Ride Mode** is marked. Press the **SET** button to open the menu.
 - Press the **UP** or **DOWN** button to activate the menu item and select it with the **SET** button. Press the **SET** button to select the engine and motorcycle traction control settings that are coordinated with each other.
 - ✓ **SPORT** – homologated performance with very direct response; the motorcycle traction control allows greater slip on the rear wheel.
 - ✓ **STREET** – homologated performance with balanced response; the motorcycle traction control allows normal slip on the rear wheel.
 - ✓ **RAIN** – reduced homologated performance for better rideability; the motorcycle traction control allows normal slip on the rear wheel.

- ✓ OFFROAD – reduced homologated performance for better ridability; the motorcycle traction control allows high slip on the rear wheel.

**Info**

Do not open the throttle during the selection.

7.25.26 MTC

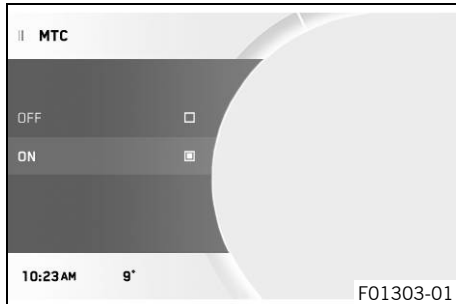
**Condition**

- The motorcycle is stationary.
 - Cruise control system function deactivated
- Press the **SET** button when the menu is closed.
 - Press the **UP** or **DOWN** button until **Motorcycle** is marked. Press the **SET** button to open the menu.
 - Press the **UP** or **DOWN** button until **MTC** is marked. Press the **SET** button to open the menu.
 - Activate the menu item using the **UP** or **DOWN** button.
 - Switch the **MTC** on or off by pressing the **SET** button.

**Info**

Do not open the throttle when switching on or off. After the ignition is switched back on, motorcycle traction control is enabled again.

7 COMBINATION INSTRUMENT

Press and hold the **SET** button for 3 - 5 seconds.

Activation of the motorcycle traction control.

7.25.27 MTC+MSR (optional)

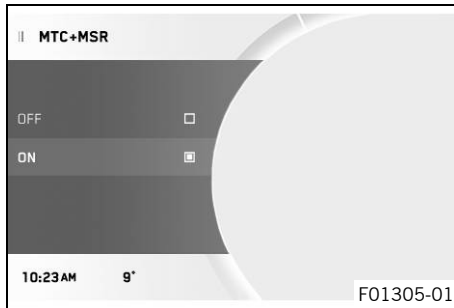

Condition

- The motorcycle is stationary.
 - Cruise control system function deactivated
- Press the **SET** button when the menu is closed.
 - Press the **UP** or **DOWN** button until **Motorcycle** is marked. Press the **SET** button to open the menu.
 - Press the **UP** or **DOWN** button until **MTC+MSR** is marked. Press the **SET** button to open the menu.
 - Activate the menu item using the **UP** or **DOWN** button.
 - Switch the **MTC+MSR** on or off by pressing the **SET** button.



Info

Do not open the throttle when switching on or off. When the ABS is switched off or the Ride Mode **Offroad** is active, the **MSR** is not active. After the ignition is switched on, the motorcycle traction control and engine traction torque control are enabled again.

Press and hold the **SET** button for 3 - 5 seconds.

Activation of the motorcycle traction control and the engine traction torque control.

7.25.28 ABS

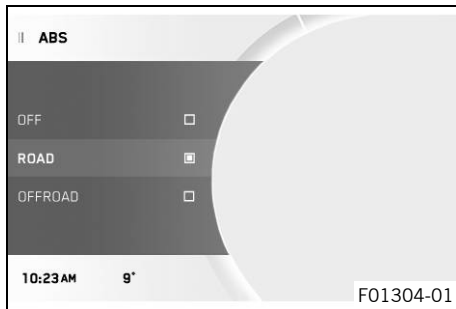

Condition

- The motorcycle is stationary.
- Press the **SET** button when the menu is closed.
- Press the **UP** or **DOWN** button until **Motorcycle** is marked. Press the **SET** button to open the menu.
- Press the **UP** or **DOWN** button until **ABS** is marked. Press the **SET** button to open the menu.
- Activate the menu item using the **UP** or **DOWN** button.
- Press the **ABS** button to switch off **SET** or to select between ABS modes.



Info

Do not open the throttle during the selection.

The ABS can only be reactivated by switching on the ignition again.

When the **Road** ABS mode is enabled, ABS controls both wheels.

When the **Offroad** ABS mode is enabled, ABS only controls the front wheel. The rear wheel is not controlled by ABS and may lock during braking maneuvers.

Press and hold the SET button for 3 - 5 seconds.	Activation of the different ABS modes.
---	--

7.25.29 HHC (optional)

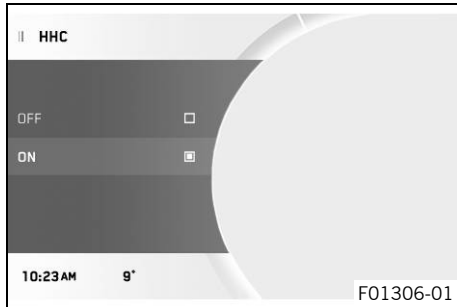

Condition

- The motorcycle is stationary.
 - Press the **SET** button when the menu is closed.
 - Press the **UP** or **DOWN** button until **Motorcycle** is marked. Press the **SET** button to open the menu.
 - Press the **UP** or **DOWN** button until **HHC** is marked. Press the **SET** button to open the menu.
 - Activate the menu item using the **UP** or **DOWN** button.
 - Switch the **HHC** on or off by pressing the **SET** button.

7.25.30 Settings

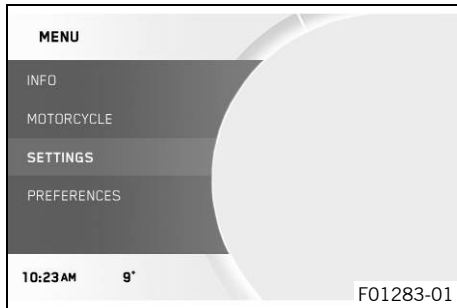

Condition

- The motorcycle is stationary.
 - Press the **SET** button when the menu is closed.
 - Press the **UP** or **DOWN** button until **Settings** is marked. Press the **SET** button to open the menu.

Favorites and quick selection can be configured in **Settings**.

7 COMBINATION INSTRUMENT

7.25.31 Favourites

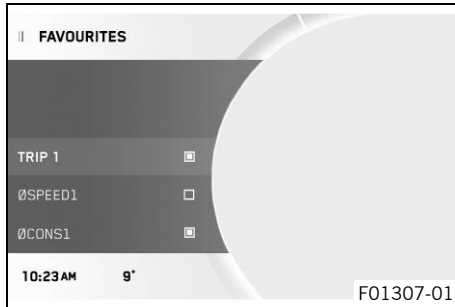

Condition

- The motorcycle is stationary.
 - Press the **SET** button when the menu is closed.
 - Press the **UP** or **DOWN** button until **Settings** is marked. Press the **SET** button to open the menu.
 - Press the **UP** or **DOWN** button until **Favourites** is marked. Press the **SET** button to open the menu.
 - Press the **UP** or **DOWN** button to activate the menu item and select it with the **SET** button.

Up to eight items of information can be selected in the **Favourites** menu.

7.25.32 Navigation Info Screen

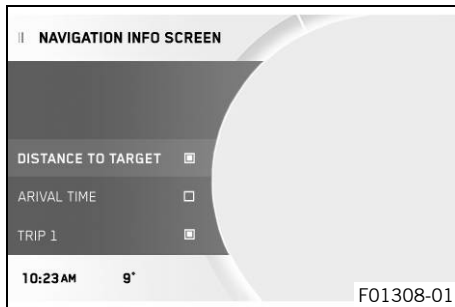

Condition

- The motorcycle is stationary.
 - Press the **SET** button when the menu is closed.
 - Press the **UP** or **DOWN** button until **Settings** is marked. Press the **SET** button to open the menu.
 - Press the **UP** or **DOWN** button until **Navigation Info Screen** is marked. Press the **SET** button to open the menu.
 - Press the **UP** or **DOWN** button to activate the menu item and select it with the **SET** button.

Up to four sets of information can be selected in the **Navigation Info Screen** menu.

7.25.33 Quick Selector 1

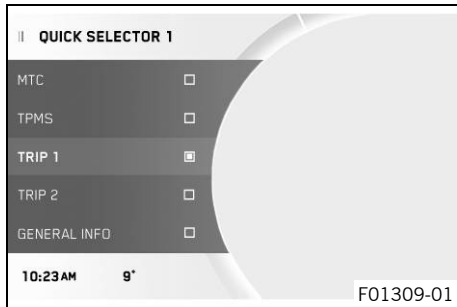

Condition

- The motorcycle is stationary.
- Press the **SET** button when the menu is closed.
- Press the **UP** or **DOWN** button until **Settings** is marked. Press the **SET** button to open the menu.
- Press the **UP** or **DOWN** button until **Quick Selector 1** is marked. Press the **SET** button to open the menu.
- Press the **UP** or **DOWN** button to activate the menu item and select it with the **SET** button.

A menu can be defined for direct selection in the **Quick Selector 1** menu.

When the menu is closed, the menu defined in **Quick Selector 1** is opened by pressing the **UP** button.

7.25.34 Quick Selector 2

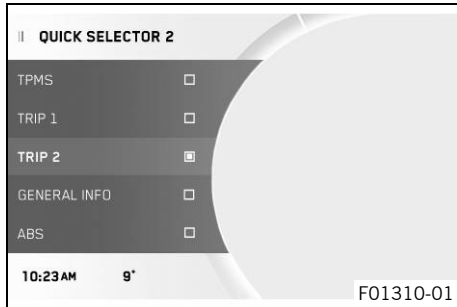

Condition

- The motorcycle is stationary.
 - Press the **SET** button when the menu is closed.
 - Press the **UP** or **DOWN** button until **Settings** is marked. Press the **SET** button to open the menu.
 - Press the **UP** or **DOWN** button until **Quick Selector 2** is marked. Press the **SET** button to open the menu.
 - Press the **UP** or **DOWN** button to activate the menu item and select it with the **SET** button.

A menu can be defined for direct selection in the **Quick Selector 2** menu.

When the menu is closed, the menu defined in **Quick Selector 2** is opened by pressing the **DOWN** button.

7.25.35 Preferences

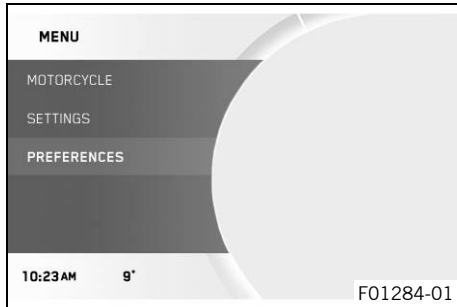

Condition

- The motorcycle is stationary.
 - Press the **SET** button when the menu is closed.
 - Press the **UP** or **DOWN** button until **Preferences** is marked. Press the **SET** button to open the menu.

The combination instrument display can be configured in **Preferences**. Settings can be made for units or various values. Several functions can be enabled or disabled.

7.25.36 Units

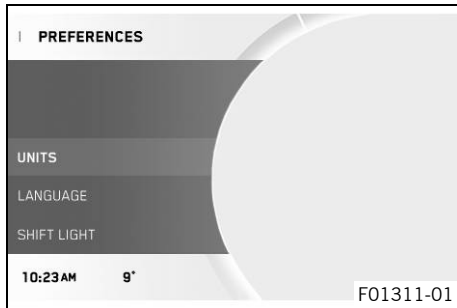

Condition

- The vehicle is stationary.
 - Press the **SET** button when the menu is closed.
 - Press the **UP** or **DOWN** button until **Preferences** is marked. Press the **SET** button to open the menu.
 - Press the **UP** or **DOWN** button until **Units** is marked.
 - Press the **SET** button to open the menu.

Units allows settings to be made for units or various values.

7 COMBINATION INSTRUMENT

7.25.37 Distance

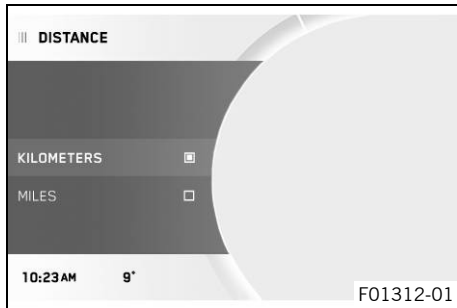

Condition

- The motorcycle is stationary.
 - Press the **SET** button when the menu is closed.
 - Press the **UP** or **DOWN** button until **Preferences** is marked. Press the **SET** button to open the menu.
 - Press the **UP** or **DOWN** button until **Units** is marked.
 - Press the **SET** button to open the menu.
 - Press the **UP** or **DOWN** button until **Distance** is marked. Press the **SET** button to open the menu.
 - Activate the menu item using the **UP** or **DOWN** button.
 - Press the **SET** button to confirm the desired unit.

7.25.38 Temperature

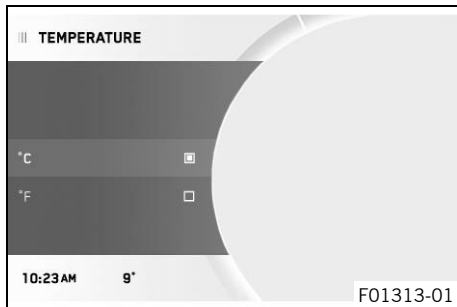

Condition

- The motorcycle is stationary.
 - Press the **SET** button when the menu is closed.
 - Press the **UP** or **DOWN** button until **Preferences** is marked. Press the **SET** button to open the menu.
 - Press the **UP** or **DOWN** button until **Units** is marked.
 - Press the **SET** button to open the menu.
 - Press the **UP** or **DOWN** button until **Temperature** is marked. Press the **SET** button to open the menu.

- Activate the menu item using the **UP** or **DOWN** button.
- Press the **SET** button to confirm the desired unit.

7.25.39 Pressure

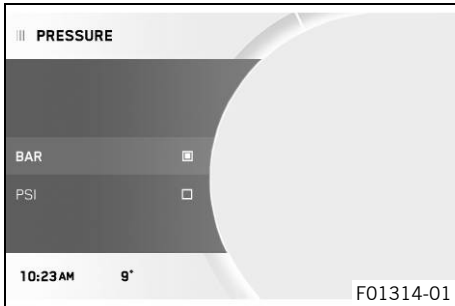

Condition

- The motorcycle is stationary.
- Press the **SET** button when the menu is closed.
- Press the **UP** or **DOWN** button until **Preferences** is marked. Press the **SET** button to open the menu.
- Press the **UP** or **DOWN** button until **Units** is marked.
- Press the **SET** button to open the menu.
- Press the **UP** or **DOWN** button until **Pressure** is marked. Press the **SET** button to open the menu.
- Activate the menu item using the **UP** or **DOWN** button.
- Press the **SET** button to confirm the desired unit.

7.25.40 Consumption

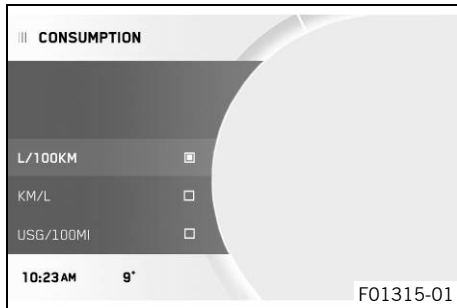

Condition

- The motorcycle is stationary.
 - Press the **SET** button when the menu is closed.
 - Press the **UP** or **DOWN** button until **Preferences** is marked. Press the **SET** button to open the menu.
 - Press the **UP** or **DOWN** button until **Units** is marked.
 - Press the **SET** button to open the menu.
 - Press the **UP** or **DOWN** button until **Consumption** is marked. Press the **SET** button to open the menu.
 - Activate the menu item using the **UP** or **DOWN** button.
 - Press the **SET** button to confirm the desired unit.

7.25.41 Language

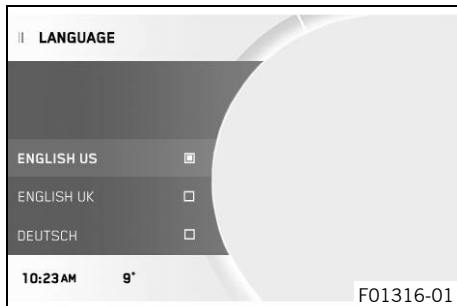

Condition

- The motorcycle is stationary.
 - Press the **SET** button when the menu is closed.
 - Press the **UP** or **DOWN** button until **Preferences** is marked. Press the **SET** button to open the menu.
 - Press the **UP** or **DOWN** button until **Language** is marked. Press the **SET** button to open the menu.
 - Press the **UP** or **DOWN** button to activate the menu item and select it with the **SET** button.

The menu languages are US English, UK English, German, Italian, French, and Spanish.

7.25.42 Shift Light

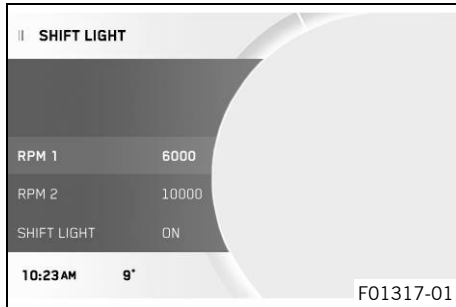

Condition

- The motorcycle is stationary.
- **ODO** > 1000 km (621 mi).
- Press the **SET** button when the menu is closed.
- Press the **UP** or **DOWN** button until **Preferences** is marked. Press the **SET** button to open the menu.
- Press the **UP** or **DOWN** button until **Shift Light** is marked. Press the **SET** button to open the menu.
- Activate the menu item using the **UP** or **DOWN** button.
- Press the **SET** button to switch the shift warning light on or off and to adjust the engine speed for the gear shift recommendation.



Info

When the engine speed reaches **RPM 1**, the speed display lights up red.

When the engine speed reaches **RPM 2**, the speed display flashes red.

7.25.43 Setting the time and date

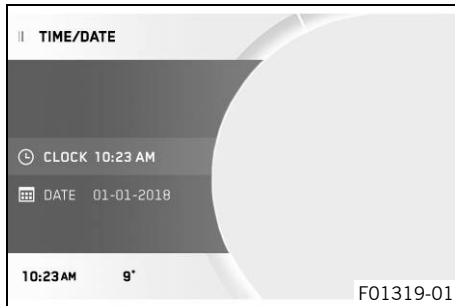
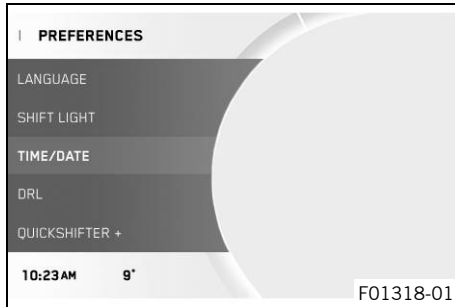

Condition

The motorcycle is stationary.

- Press the **SET** button when the menu is closed.
- Press the **UP** or **DOWN** button until **Preferences** appears. Press the **SET** button to open the menu.
- Press the **UP** or **DOWN** button until **Time/Date** is marked. Press the **SET** button to open the menu.

Setting the clock

- Press the **UP** or **DOWN** button until the time is marked.
- Press the **SET** button.
 - ✓ The hour next to **Clock** flashes.
- Press the **UP** or **DOWN** button until the current hour is set.
- Press the **SET** button.
 - ✓ The minute next to **Clock** flashes.
- Press the **UP** or **DOWN** button until the current minute is set.
- Press the **SET** button.
 - ✓ The time is stored.

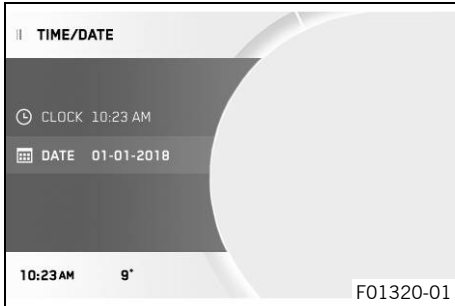

Setting the date

- Press the **UP** or **DOWN** button until the date is marked.
- Press the **SET** button.
 - ✓ The day next to **Date** flashes.
- Press the **UP** or **DOWN** button until the current day is set.
- Press the **SET** button.
 - ✓ The month next to **Date** flashes.
- Press the **UP** or **DOWN** button until the current month is set.
- Press the **SET** button.
 - ✓ The year next to **Date** flashes.
- Press the **UP** or **DOWN** button until the current year is set.
- Press the **SET** button.
 - ✓ The date is stored.



7.25.44 DRL

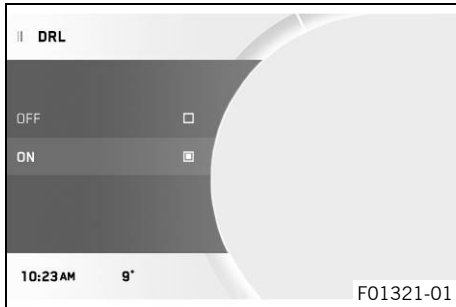

Condition

- The motorcycle is stationary.
- Press the **SET** button when the menu is closed.
- Press the **UP** or **DOWN** button until **Preferences** is marked. Press the **SET** button to open the menu.



Warning

Danger of accidents When visibility is poor, the daytime running light is not a substitute for the low beam. Automatic switching between the daytime running light and low beam may only be partially available when visibility is significantly impaired due to fog, snow or rain.

- Ensure that the appropriate type of lighting is always selected.
- If necessary switch off the daytime running lights using the menu before going on a ride or when stopped so that the low beam is switched on permanently.
- Note the legal regulations regarding the daytime running light.

- Press the **UP** or **DOWN** button until **DRL** is marked. Press the **SET** button to open the menu.
- Activate the menu item using the **UP** or **DOWN** button.
- Press the **SET** button to switch the daytime running light on or off.

7.25.45 Quickshifter + (optional)

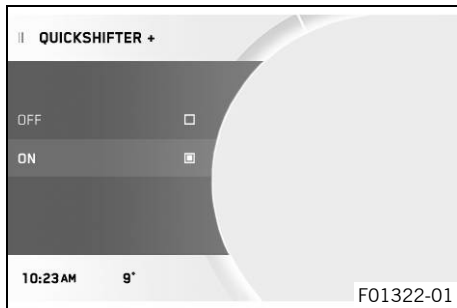

Condition

- The motorcycle is stationary.
- Press the **SET** button when the menu is closed.
- Press the **UP** or **DOWN** button until **Preferences** is marked. Press the **SET** button to open the menu.
- Press the **UP** or **DOWN** button until **Quickshifter +** is marked. Press the **SET** button to open the menu.
- Activate the menu item using the **UP** or **DOWN** button.
- Press the **SET** button to switch the quickshifter + on or off.

7 COMBINATION INSTRUMENT

7.25.46 Heated Grips (optional)

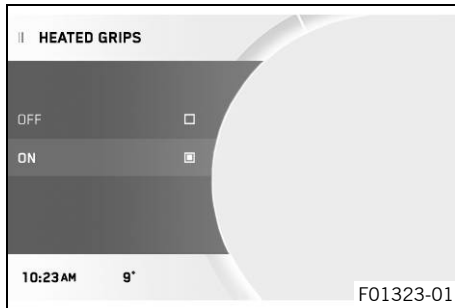

Condition

- The motorcycle is stationary.
 - Press the **SET** button when the menu is closed.
 - Press the **UP** or **DOWN** button until **Preferences** is marked. Press the **SET** button to open the menu.
 - Press the **UP** or **DOWN** button until **Heated Grips** is marked. Press the **SET** button to open the menu.
 - Activate the menu item using the **UP** or **DOWN** button.
 - Switch the **Heated Grips** on or off by pressing the **SET** button.

7.25.47 Heated Seat Rid (optional)

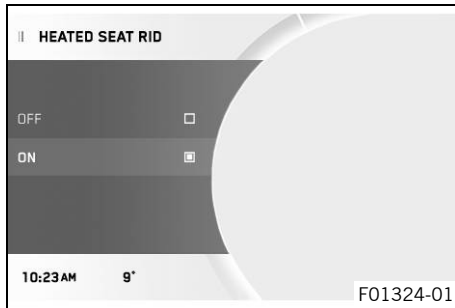

Condition

- The motorcycle is stationary.
 - Press the **SET** button when the menu is closed.
 - Press the **UP** or **DOWN** button until **Preferences** is marked. Press the **SET** button to open the menu.
 - Press the **UP** or **DOWN** button until **Heated Seat Rid** is marked. Press the **SET** button to open the menu.
 - Activate the menu item using the **UP** or **DOWN** button.
 - Switch the **Heated Seat Rid** on or off by pressing the **SET** button.

7.25.48 Heated Seat Pas (optional)

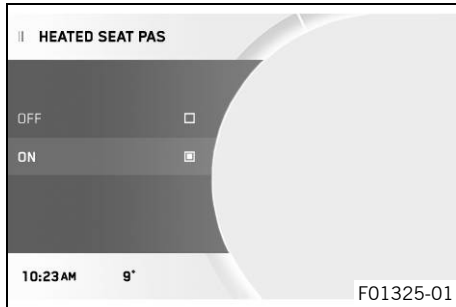

Condition

- The motorcycle is stationary.
 - Press the **SET** button when the menu is closed.
 - Press the **UP** or **DOWN** button until **Preferences** is marked. Press the **SET** button to open the menu.
 - Press the **UP** or **DOWN** button until **Heated Seat Pas** is marked. Press the **SET** button to open the menu.
 - Activate the menu item using the **UP** or **DOWN** button.
 - Switch the **Heated Seat Pas** on or off by pressing the **SET** button.

7.25.49 Cornering Light Test

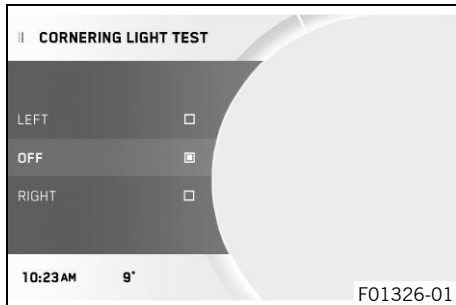

Condition

- The motorcycle is stationary.
 - Press the **SET** button when the menu is closed.
 - Press the **UP** or **DOWN** button until **Preferences** is marked. Press the **SET** button to open the menu.
 - Press the **UP** or **DOWN** button until **Cornering Light Test** is marked. Press the **SET** button to open the menu.
 - Activate the menu item using the **UP** or **DOWN** button.



Info

The **Cornering Light Test** is performed on the left cornering light in the **Left** submenu.

The **Cornering Light Test** is performed on the right cornering light in the **Right** submenu.

The **Cornering Light Test** is completed in the **Off** submenu.

- Press the **SET** button in order to perform or switch off the desired **Cornering Light Test**.
-



Info

The respective cornering light segments light up in succession, starting with the lower segment.

When the test of the respective cornering light is complete, the upper segment lights up continuously.

8.1 Handlebar position

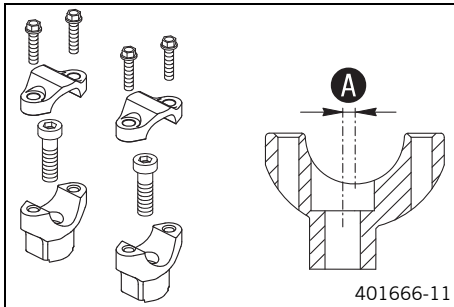

The holes on the handlebar support are placed at a distance of **A** from the center.

Hole distance A	3.5 mm (0.138 in)
------------------------	-------------------

The handlebar can be mounted in two different positions. In this way, the handlebar can be mounted in the position that is most comfortable for the rider.

8.2 Adjusting the handlebar position ↩



Warning

Danger of accidents A repaired handlebar poses a safety risk.

If the handlebar is bent or straightened, the material becomes fatigued. The handlebar may break as a result.

- Change the handlebar if the handlebar is damaged or bent.

8 ERGONOMICS

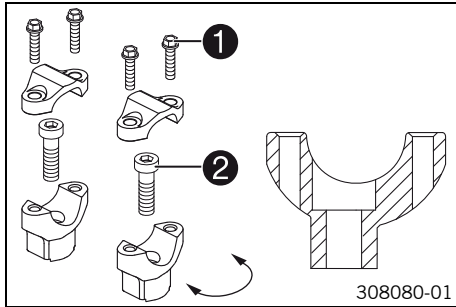

- Remove screws **1**. Take off the handlebar clamps. Remove the handlebar and lay it to one side.



Info

Cover the components to protect them against damage. Do not kink the cables and lines.

- Remove screws **2**. Take off the handlebar supports.
- Place the handlebar supports in the required position. Mount and tighten screws **2**.

Guideline

Screw, handlebar support	M10	40 Nm (29.5 lbf ft) Loctite®243™
--------------------------	-----	--



Info

Position the left and right handlebar supports evenly.

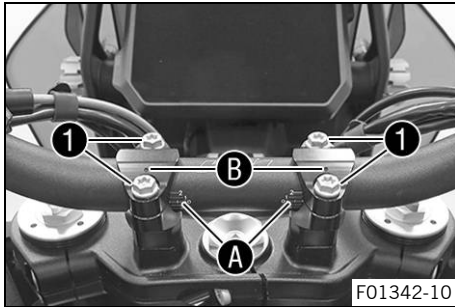

- Position the handlebar.

i Info
Make sure the cables and wiring are positioned correctly.

- Position the handlebar clamps. Mount screws **1** and tighten evenly.

Guideline

Screw, handlebar clamp	M8	20 Nm (14.8 lbf ft)
------------------------	----	---------------------

- ✓ Handlebar scale markings **A** are located centrally between the handlebar clamps.
- ✓ Markings **B** face backwards.

i Info
Make sure the gap widths are even.

8.3 Adjusting the windshield

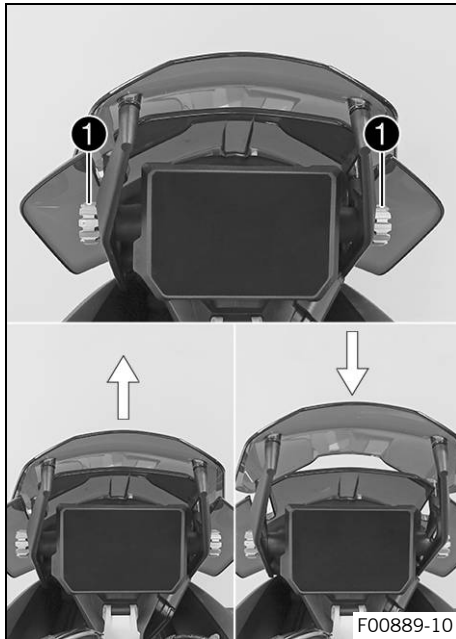

- Turn the adjusting wheel **1** to bring the windshield in the required position.

8.4 Adjusting the basic position of the clutch lever



- Adjust the basic position of the clutch lever to your hand size by turning adjusting screw ①.



Info

When the adjusting screw is turned clockwise, the clutch lever moves closer to the handlebar. When the adjusting screw is turned counterclockwise, the clutch lever moves away from the handlebar. The range of adjustment is limited. Only turn the adjusting screw by hand, and do not use force. Do not make any adjustments while riding.



8.5 Adjusting the basic position of the hand brake lever



- Adjust the basic position of the hand brake lever to your hand size by turning adjusting wheel ①.



Info

Push the hand brake lever forward and turn the adjusting wheel.

Do not make any adjustments while riding.

8.6 Rider footrests

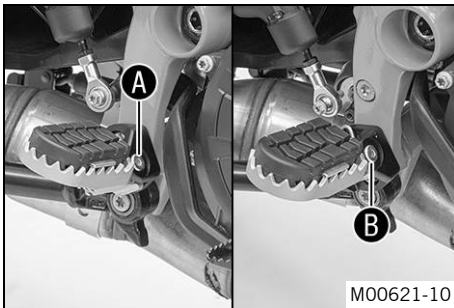

The rider footrests can be mounted in one of two positions.

Possible states

- Rider footrests, low ①
- Rider footrests, high ②

8.7 Adjusting the footrests ↩



Info

The operations on the footrest brackets are the same for the left and right sides.

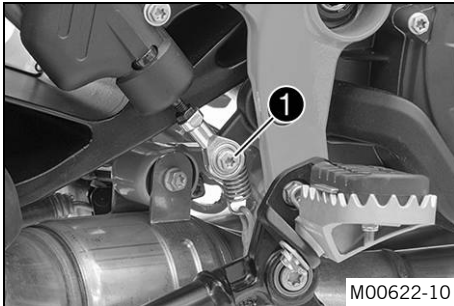

- Remove screw **1**.
- ✓ The foot brake lever swings up to the stop.

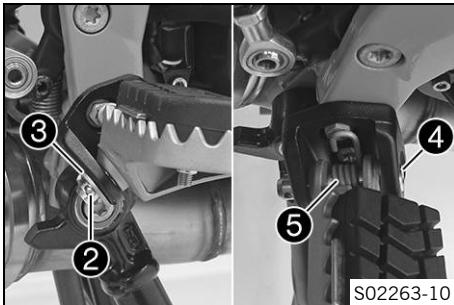

- Remove cotter pin **2** with washer **3**.
- Carefully remove the pin **4** of the rider footrest.



Info

The spring is under high tension and can pop out when the pin is removed.

- Take off the rider footrest **5** with the spring.

8 ERGONOMICS

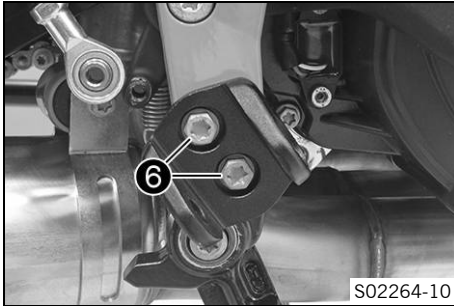

- Remove screws ⑥.



- Adjust the footrest bracket to the desired position.

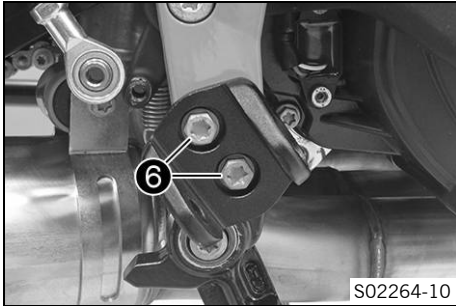

- Mount and tighten screws **6**.

Guideline

Screw, front footrest bracket	M8	25 Nm (18.4 lbf ft) Loctite®243™
-------------------------------	----	--

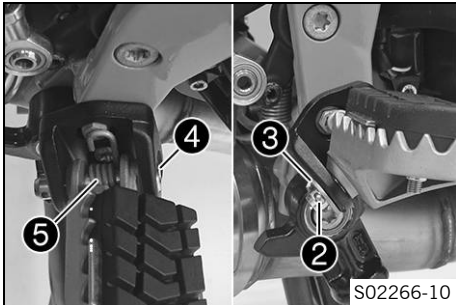

- Mount the rider footrest with spring **5** and pin **4**.

Footrest spring plier (58429083000)

- Mount washer **3** and cotter pin **2**.

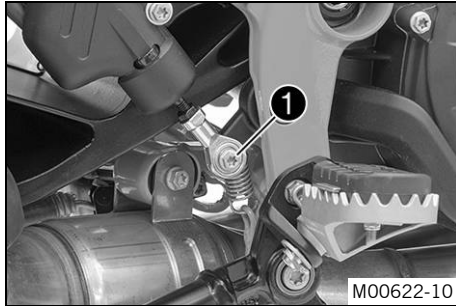

- Position the foot brake lever.
- Mount and tighten screw ①.

Guideline

Screw, ball joint of push rod on foot brake cylinder	M6	10 Nm (7.4 lbf ft) Loctite®243™
--	----	---

8.8 Checking the basic position of the shift lever



Info

When driving, the shift lever must not touch the driver's boot when in the basic position. When the shift lever keeps touching the boot, the transmission will be subject to an excessive load.

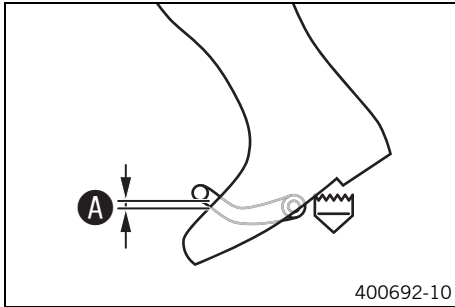

- Sit on the vehicle in the riding position and determine distance **A** between the upper edge of your boot and the shift lever.

Distance between shift lever and upper edge of boot	10 ... 20 mm (0.39 ... 0.79 in)
---	---------------------------------

- » If the distance does not meet specifications:
 - Adjust the basic position of the shift lever. 🛠️ (📖 p. 145)

8.9 Adjusting the basic position of the shift lever 🛠️

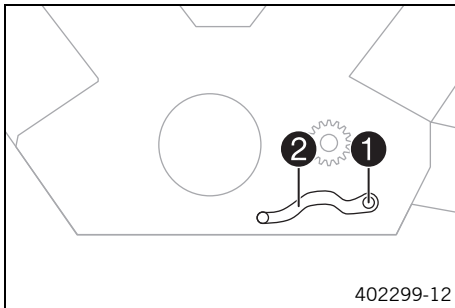

- Remove screw **1** with the washers and take off shift lever **2**.

8 ERGONOMICS

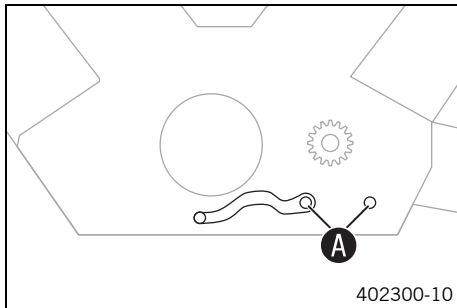

- Clean gear teeth **A** of the shift lever and shift shaft.
- Mount the shift lever on the shift shaft in the required position and engage the gearing.

i Info

The range of adjustment is limited.
The shift lever must not come into contact with any other vehicle components during the shift procedure.

- Mount and tighten screw **1** with washers.

Guideline

Screw, shift lever	M6	15 Nm (11.1 lbf ft) Loctite®243™
--------------------	----	--

8.10 Setting the shift lever stub

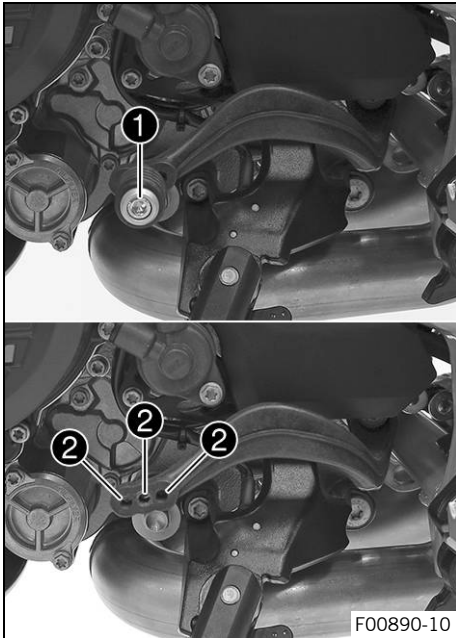

- Remove screw ① along with the shift lever stub.
- Position the shift lever stub with the screw in one of drilled holes ② depending on the desired lever length.

Guideline

Standard	Middle hole
----------	-------------

- Tighten the screw.

Guideline

Remaining chassis screws	M6	10 Nm (7.4 lbf ft)
--------------------------	----	--------------------

8.11 Adjusting the basic position of the foot brake lever ↗

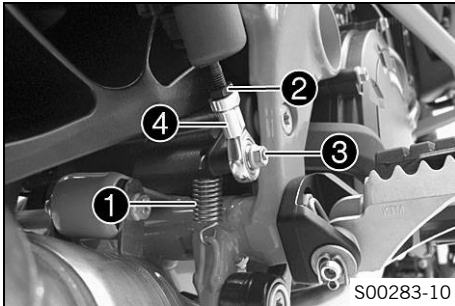

- Disconnect spring ①.
- Loosen nut ②.
- Remove screw ③.
- To adjust the basic position of the foot brake lever to individual requirements, turn ball joint ④ accordingly.



Info

The range of adjustment is limited.
The screw must be screwed into the ball joint by at least 5 turns.

- Hold ball joint ④ and tighten nut ②.

Guideline

Remaining chassis nuts	M6	10 Nm (7.4 lbf ft)
------------------------	----	--------------------

- Mount and tighten screw ③.

Guideline

Screw, ball joint of push rod on foot brake cylinder	M6	10 Nm (7.4 lbf ft) Loctite®243™
--	----	---

- Attach spring ①.

8.12 Adjusting the tilt of the combination instrument

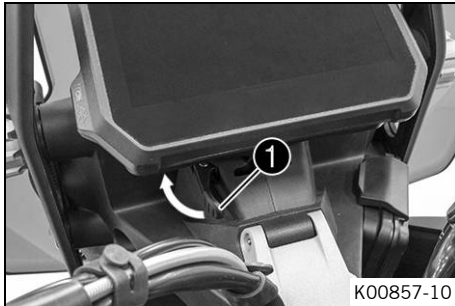

- Pull clamping lever ❶ in the direction of the arrow.
- ✓ The combination instrument is unlocked.

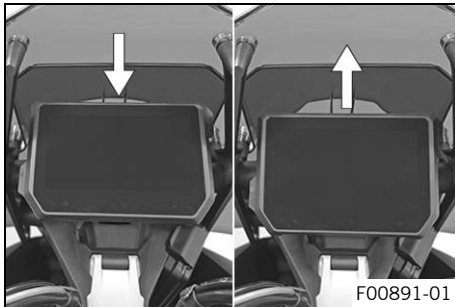

- To move the combination instrument to the desired position, press the combination instrument upward or downward.

8 ERGONOMICS



- Pull clamping lever ① in the direction of the arrow.
- ✓ The combination instrument is locked.

9.1 Advice on preparing for first use



Danger

Danger of accidents A rider who is not fit to ride poses a danger to him or herself and others.

- Do not operate the vehicle if you are not fit to ride due to alcohol, drugs or medication.
- Do not operate the vehicle if you are physically or mentally impaired.



Warning

Risk of injury Missing or poor protective clothing presents an increased safety risk.

- Wear appropriate protective clothing such as helmet, boots, gloves as well as trousers and a jacket with protectors on all rides.
- Always wear protective clothing that is in good condition and meets the legal regulations.



Warning

Danger of crashing Different tire tread patterns on the front and rear wheel impair the handling characteristic.

Different tire tread patterns can make the vehicle significantly more difficult to control.

- Make sure that only tires with a similar tire tread pattern are fitted to the front and rear wheel.



Warning

Danger of accidents Non-approved or non-recommended tires and wheels impact the handling characteristic.

- Only use tires/wheels approved by KTM with the corresponding speed index.



Warning

Danger of accidents New tires have reduced road grip.

The contact surface on new tires is not yet roughened.

- Run in new tires with moderate riding at alternating angles.
Running-in phase 200 km (124 mi)



Warning

Danger of accidents The brake system fails in the event of overheating.

If the foot brake lever is not released, the brake linings drag continuously.

- Take your foot off the foot brake lever when you are not braking.



Info

When using your vehicle, remember that others may feel disturbed by excessive noise.

- Make sure that the pre-delivery inspection work has been carried out by an authorized KTM workshop.
✓ You receive a delivery certificate and the Service and Warranty Booklet at vehicle handover.
- Before your first trip, read the entire Owner's Manual carefully.
- Get to know the controls.
- Adjust the motorcycle to your requirements, as described in the "Ergonomics" chapter.
- Get used to handling the motorcycle in a suitable area before making a longer trip. Try also to ride as slowly as possible and in a standing position to get a better feeling for the motorcycle.
- Hold the handlebar firmly with both hands and keep your feet on the footrests when riding.

- Run the engine in. (📖 p. 153)



9.2 Running in the engine

- During the running-in phase, do not exceed the specified engine speed.

Guideline

Maximum engine speed	
During the first: 1,000 km (620 mi)	6,500 rpm
After the first: 1,000 km (620 mi)	10,250 rpm

- Avoid fully opening the throttle!



Info

If the maximum engine speed is exceeded before the first service, the shift warning light flashes.



9.3 Loading the vehicle



Warning

Danger of accidents Total weight and axle loads influence the handling characteristic.

The overall weight consists of: motorcycle ready for operation and with a full tank, driver and passenger with protective clothing and helmet, and luggage.

- Do not exceed the maximum permissible overall weight or the axle loads.



Warning

Danger of accidents Improper mounting of cases or the tank rucksack impairs the handling characteristic.

- Mount and secure cases and tank rucksack according to the manufacturer's instructions.



Warning

Danger of accidents Unstable handling characteristics at high speed.

- Adapt your speed according to your payload. Ride more slowly if your motorcycle is loaded with cases or other baggage.

Maximum speed with luggage

150 km/h (93.2 mph)



Warning

Danger of accidents The luggage system will be damaged if it is overloaded.

- Read the manufacturer information on maximum payload when mounting cases.



Warning

Danger of accidents Luggage which has slipped impairs visibility.

If the tail light is covered, you are less visible to traffic behind you, especially when it is dark.

- Check that your luggage is fixed properly at regular intervals.



Warning

Danger of accidents A high payload alters the handling characteristic and increases the stopping distance.

- Adapt your speed to your payload.



Warning

Danger of accidents Pieces of luggage which have slipped impair the handling characteristic.

- Check that your luggage is fixed properly at regular intervals.



Warning

Fire hazard The hot exhaust system may burn luggage.

- Fasten your luggage in such a way that it cannot be burned or singed by the hot exhaust system.

-
- If you are carrying baggage, make sure it is fixed firmly as close as possible to the center of the vehicle and ensure even weight distribution between the front and rear wheels.
 - Do not exceed the maximum permitted total weight and the axle loads.

Guideline

Maximum permissible total weight	450 kg (992 lb.)
Maximum permissible front axle load	165 kg (364 lb.)
Maximum permissible rear axle load	285 kg (628 lb.)



10.1 Checks and maintenance measures when preparing for use

i Info

Before every trip, check the condition of the vehicle and ensure that it is roadworthy. The vehicle must be in perfect technical condition when it is being operated.

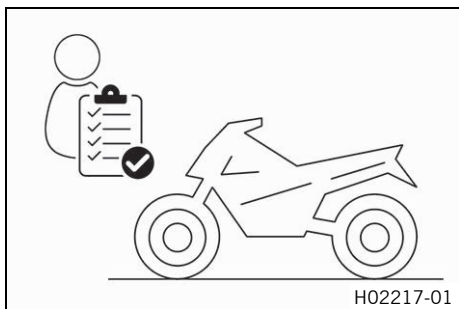

- Check the engine oil level. (📖 p. 296)
- Check the brake fluid level of the front brake. (📖 p. 235)
- Check the rear brake fluid level. (📖 p. 240)
- Check the front brake linings. (📖 p. 239)
- Check the rear brake linings. (📖 p. 244)
- Check that the brake system is functioning properly.
- Check the coolant level in the compensating tank. (📖 p. 289)
- Check the chain for dirt. (📖 p. 196)
- Check the chain tension. (📖 p. 198)
- Check the tire condition. (📖 p. 258)
- Check the tire air pressure. (📖 p. 261)
- Check the spoke tension. (📖 p. 262)
- Check the settings of all controls and ensure that they can be operated smoothly.
- Check that the electrical system is functioning properly.
- Check that luggage is properly secured.
- Check the setting of the rear mirror.

- Check the fuel level.



10.2 Starting



Danger

- Danger of poisoning** Exhaust gases are toxic and inhaling them may result in unconsciousness and death.
- Always make sure there is sufficient ventilation when running the engine.
 - Use an effective exhaust extraction system when starting or running the engine in an enclosed space.



Caution

- Danger of accidents** Electronic components and safety devices will be damaged if the battery is discharged or missing.
- Never operate the vehicle with a discharged battery or without a battery.

Note

- Engine damage** High revving speed with a cold engine negatively impacts the lifespan of the engine.
- Always run the engine warm at a low speed.

10 RIDING INSTRUCTIONS

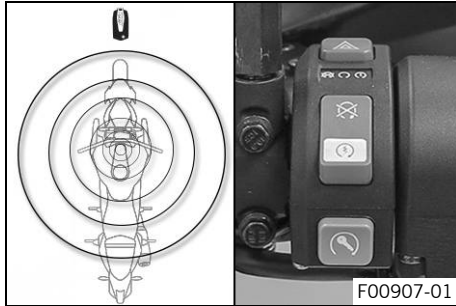

- Take the motorcycle off side stand and sit in the motorcycle.
- Bring the Race-on key within range of the antenna.
- Ensure that the Race-on key stays in range while riding.

Guideline

Maximum range of the Race-on key around the antenna	1.5 m (4.9 ft)
---	----------------



Info

The range may be reduced by decreases in battery voltage of the Race-on key and interfering radio waves. If the battery voltage of the Race-on key is too low, one of the keys must be held in area of the antenna (📖 p. 50) and must be safely stored again after starting.

- Make sure that the emergency OFF switch/electric starter button is in the middle position ○.
- Switch on ignition; to do this, briefly press the Race-on tip switch ⚡ (maximum of 1 second).
 - ✓ The steering is unlocked.
 - ✓ The function check of the combination instrument is run.
 - ✓ The ABS indicator lamp goes out when you start off.

**Info**

If the handlebar does not unlock, move the handlebar slightly.

- Shift the transmission to idle **N**.
- ✓ The green idling speed indicator lamp **N** lights up.
- Turn the emergency OFF switch/electric starter button to the lower position **Ⓢ**.

**Info**

Do not press the emergency off switch/electric starter button into the lower position **Ⓢ** until the combination instrument function check has been completed.

When starting, **DO NOT** open the throttle. If you open the throttle during the starting procedure, fuel is not injected by the engine management system and the engine cannot start.

Press the emergency OFF switch/electric starter button into the lower position **Ⓢ** for a maximum of 5 seconds. Wait for at least 5 seconds before trying again.

This motorcycle is equipped with a safety starting system. You can only start the engine if the transmission is in neutral or if the clutch lever is pulled when a gear is engaged. If the side stand is folded out and you shift into gear, the engine stops.



10 RIDING INSTRUCTIONS

10.3 Starting off

- Pull the clutch lever, engage 1st gear, release the clutch lever slowly and simultaneously open the throttle carefully.



10.4 Quickshifter + (optional)

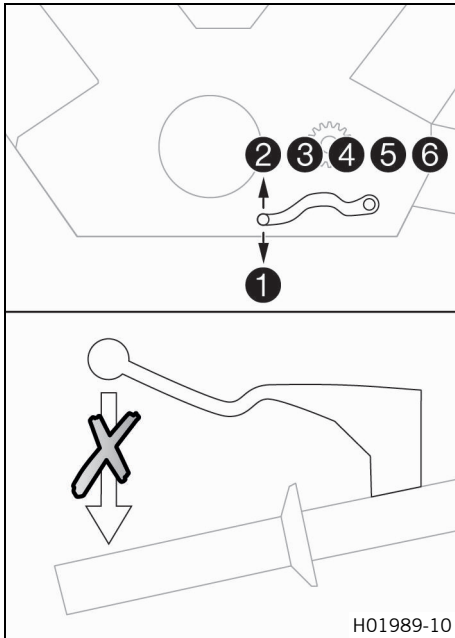

If the quickshifter + (optional) is activated, you can shift up and down without actuating the clutch.

Because there is no need to close the throttle grip, uninterrupted gear shifts are possible.

The quickshifter + uses the shifter shaft position to check whether or not a shift should be initiated, and sends a corresponding signal to the engine control.

If the quickshifter + is disabled in the combination instrument, the clutch needs to be actuated in the normal way for each shift.

10.5 Starting off with HHC (optional)

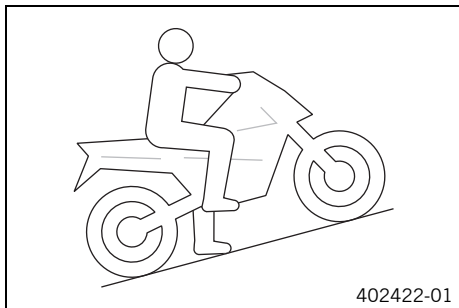

The **HHC** is an optional auxiliary function of the brake system. The **HHC** prevents accidental rolling back of the motorcycle on hills.

The **HHC** recognizes stopping on hills and operates the rear brake. After releasing the brake lever, the brake force is maintained for a maximum of 5 seconds as long as the motorcycle is not moving forward.

When driving off the **HHC** releases the rear brake automatically.

i Info

When the **HHC** is active, the TC indicator lamp  flashes. When the ignition is switched on, the **HHC** can still be active even if the engine is stopped.

To roll back with active **HHC**, wait 5 seconds, shift to neutral, or switch off the ignition.

If the **HHC** does not detect a start off after 5 seconds, the braking force is automatically reduced gently.

When a brake lever is actuated, the **HHC** is re-activated.

10.6 Shifting, riding



Warning

Danger of accidents Abrupt load alterations can cause the vehicle to get out of control.

- Avoid abrupt load alterations and sudden braking actions.
- Adapt your speed to the road conditions.



Warning

Danger of accidents If you change down at high engine speed, the rear wheel blocks and the engine races.

- Do not change into a low gear at high engine speed.



Warning

Danger of accidents Adjustments to the vehicle distract attention from traffic activity.

- Make all adjustments when the vehicle is at a standstill.



Warning

Risk of injury The passenger may fall from the motorcycle if they conduct themselves incorrectly.

- Ensure that the passenger sits correctly on the passenger seat, places his or her feet on the passenger foot rest and holds on to the rider or the grab handles.
- Note the regulations governing the minimum age of passengers in your country.

10 RIDING INSTRUCTIONS



Warning

Danger of accidents A risky riding style constitutes a major risk.

- Comply with traffic regulations and ride defensively and with foresight to detect sources of danger as early as possible.



Warning

Danger of accidents Cold tires have reduced road grip.

- Ride the first miles carefully on every journey at moderate speed until the tires reach operating temperature.



Warning

Danger of accidents New tires have reduced road grip.

The contact surface on new tires is not yet roughened.

- Run in new tires with moderate riding at alternating angles.
Running-in phase 200 km (124 mi)



Warning

Danger of accidents Total weight and axle loads influence the handling characteristic.

The overall weight consists of: motorcycle ready for operation and with a full tank, driver and passenger with protective clothing and helmet, and luggage.

- Do not exceed the maximum permissible overall weight or the axle loads.

**Warning**

Danger of accidents Pieces of luggage which have slipped impair the handling characteristic.

- Check that your luggage is fixed properly at regular intervals.

**Warning**

Danger of accidents A fall can damage the vehicle more seriously than it may first appear.

- Check the vehicle after a fall as you do when preparing for use.

Note

Engine damage Unfiltered intake air has a negative effect on the service life of the engine.

Dust and dirt will enter the engine without an air filter.

- Never start to use the vehicle without an air filter.

Note

Engine failure Overheating damages the engine.

- If the coolant temperature warning is displayed, stop immediately and take care not to endanger yourself or other traffic participants in the process.
- Allow the engine and cooling system to cool down.
- Check and, if necessary, correct the coolant level on the cooling system while it is in a cooled state.

Note

Transmission damage Incorrect use of the quickshifter+ will damage the transmission.

The quickshifter+ can only be used if the function is enabled in the combination instrument.

The quickshifter+ is not active if you pull the clutch lever.

- Only use the quickshifter+ in the permitted speed range shown.



Info

If you hear unusual noises while riding, stop immediately, switch off the engine, and contact an authorized KTM workshop.

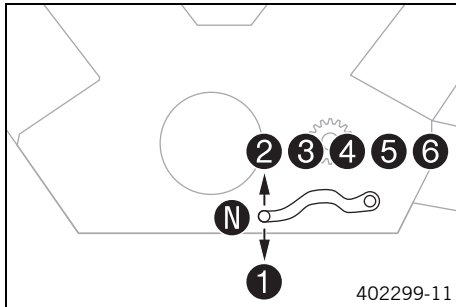

- Shift into a higher gear when conditions allow (incline, road situation, etc.).
- Release the throttle while simultaneously pulling the clutch lever, shift into the next gear, release the clutch lever, and open the throttle.





Info

You can see the positions of the 6 forward gears in the figure. The idle position is between the first and second gears. First gear is used for starting off or for steep inclines.

- After reaching maximum speed by fully opening the throttle grip, turn the throttle back so it is $\frac{3}{4}$ open. This will barely

reduce the speed but fuel consumption will be considerably lower.

- Accelerate only up to a speed suitable for the road surface and weather conditions. Particularly in bends, do not shift, and accelerate very carefully.
- Brake if necessary and close the throttle at the same time in order to shift down.
- Pull the clutch lever and shift into a lower gear, release the clutch lever slowly, and open the throttle or shift again.
- If the engine stalls (e.g. at a crossroads), just pull the clutch lever and press the electric starter button. You do not have to shift into neutral.
- Switch off the engine if running at idle or stationary for a long time.
- If the oil pressure warning lamp  lights up during a trip, stop immediately and switch off the engine. Contact an authorized KTM workshop.
- If the malfunction indicator lamp  lights up during a trip, please contact an authorized KTM workshop as soon as possible.
- If the general warning lamp  lights up during a trip, the display shows a message for 10 seconds.

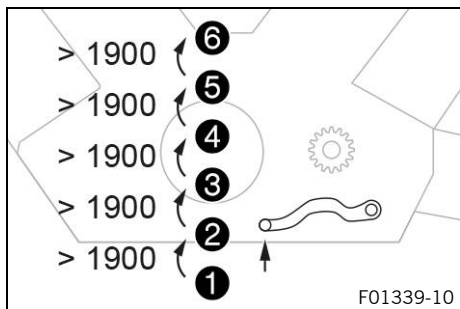

Info

Very important messages are stored in the **Warning** menu.

- If the icy road symbol ❄ appears in the combination instrument, the roads may be icy. Adjust your speed to the road conditions.

Condition

Quickshifter + (optional) activated.

- If the quickshifter + is enabled in the combination instrument, you can shift up in the speed range shown without pulling the clutch lever.



Info

The minimum engine speed before shifting up in revolutions per minute is shown in the figure. Pull the shift lever quickly back to the stop without changing the throttle twist grip position.

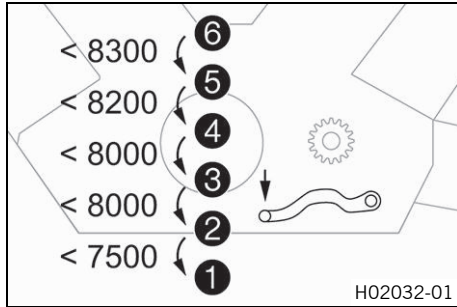

- If the quickshifter + is enabled in the combination instrument, you can shift down in the speed range shown without pulling the clutch lever.



Info

The maximum engine speed before shifting down in revolutions per minute is shown in the figure. Depress the shift lever quickly back to the stop without changing the throttle twist grip position.



10.7 MSR (optional)

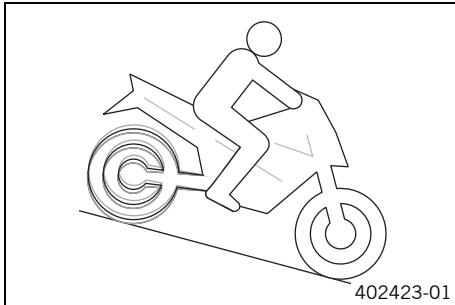

The **MSR** is an optional auxiliary function of the engine control. If the engine braking effect is too great, the **MSR** prevents the rear wheel from locking or sliding away on a sloping position. To avoid slip of the rear wheel, the **MSR** only opens the throttle valve as far as absolutely necessary. The **MSR** is applied on surfaces, where the friction is too low to open the anti-hopping clutch. To further increase ride safety, the **MSR** is slope dependent.



Info

If **ABS** is disabled, **MTC** is disabled or **ABS Mode Offroad** is enabled, the **MSR** is not active.

10.8 Applying the brakes



Warning

Danger of accidents Moisture and dirt impair the brake system.

- Brake carefully several times to dry out and remove dirt from the brake linings and the brake discs.



Warning

Danger of accidents A spongy pressure point on the front or rear brake reduces braking efficiency.

- Check the brake system and do not continue riding until the problem is eliminated. (Your authorized KTM workshop will be glad to help.)



Warning

Danger of accidents The brake system fails in the event of overheating.

If the foot brake lever is not released, the brake linings drag continuously.

- Take your foot off the foot brake lever when you are not braking.



Warning

Danger of accidents Higher total weight increases the stopping distance.

- Take the longer stopping distance into account when carrying a passenger or luggage with you.



Warning

Danger of accidents Salt on the roads impairs the brake system.

- Brake carefully several times to remove salt from the brake linings and the brake discs.

**Warning**

Danger of accidents ABS may increase the stopping distance in certain situations.

- Adjust application of the brakes to the respective riding situation and riding surface conditions.

**Warning**

Danger of accidents Excessively forceful application of the brakes blocks the wheels.

The ABS effectiveness is only ensured if it is switched on.

- Leave the ABS switched on in order to benefit from the protective effect.

**Warning**

Danger of accidents Driving aids can only prevent a rollover within the physical limitations.

It is not always possible to compensate for extreme riding situations, for example with luggage loaded with a high center of gravity, varying road surfaces, steep descents or full braking without disengaging the gear.

- Adapt your riding style to the road conditions and your driving ability.

-
- When braking, release the throttle and apply the front and rear brakes at the same time.

**Info**

When the ABS is enabled, you can achieve maximum braking power even on low grip surfaces such as sandy, wet, or slippery terrain without locking of the wheels.



Warning

Danger of accidents The rear wheel can lock due to the engine braking effect.

- Pull in the clutch, if you perform emergency or full braking, or if you brake on a slippery ground.



Warning

Danger of accidents Banked or laterally sloping ground reduces the maximum possible delay.

- If possible finish braking before going into a bend.

- Braking should always be completed before you go into a bend. Change down to a lower gear appropriate to your road speed.
- On long downhill stretches, use the braking effect of the engine. Change down one or two gears, but do not over-rev the engine. In this way, you have to brake far less and the brakes do not overheat.



10.9 Stopping, parking



Warning

Risk of injury People who act without authorization endanger themselves and others.

If a valid transponder is in range, the vehicle can be started.

- Do not leave the vehicle unattended if the engine is running.
- Never leave the vehicle unattended if the Race-on key or the black Race-on key are close to the vehicle.
- Protect the vehicle against access by unauthorized persons.
- Lock the steering if you leave the vehicle unattended.



Warning

Danger of burns Some vehicle components become very hot when the vehicle is operated.

- Do not touch any parts such as the exhaust system, radiator, engine, shock absorber, or brake system before the vehicle parts have cooled down.
- Let the vehicle parts cool down before you perform any work on the vehicle.

Note

Fire hazard Hot vehicle components pose a fire hazard and explosion risk.

- Do not park the vehicle near to materials which are highly flammable or explosive.
- Allow the vehicle to cool down before covering it.

Note

Material damage The vehicle may be damaged by incorrect procedure when parking. Significant damage may be caused if the vehicle rolls away or falls over. The components for parking the vehicle are designed only for the weight of the vehicle.

- Park the vehicle on a firm and level surface.
 - Ensure that nobody sits on the vehicle when the vehicle is parked on a stand.
-
- Apply the brakes on the motorcycle.
 - Shift the transmission to idle **N**.
 - Switch off ignition - to do this briefly press the Race-on button  (maximum of 1 second) with the ignition switched on.



Info



If the engine is switched off with the emergency OFF switch and the ignition remains switched on at the Race-on tip switch, the power supply to most power consumers remains unbroken. This discharges the battery. You should therefore always switch off the engine with the Race-on tip switch – the emergency OFF switch is intended for emergencies only.

-
- Park the motorcycle on a firm surface.

Alternative 1

- Swing the side stand forward with your foot as far as it will go and lean the vehicle on it.

Alternative 2

- Raise the vehicle with the center stand.  p. 193
- Move handlebar fully to the left and press and hold the Race-on button  (for at least 2 seconds).
 - ✓ The steering is locked.

**Info**

If the handlebar lock does not engage, move the handlebar slightly.



10.10 Transporting

Note

Danger of damage The parked vehicle can roll away or fall over.

- Park the vehicle on a firm and level surface.

Note

Fire hazard Hot vehicle components pose a fire hazard and explosion risk.

- Do not park the vehicle near to materials which are highly flammable or explosive.
 - Allow the vehicle to cool down before covering it.
-

10 RIDING INSTRUCTIONS

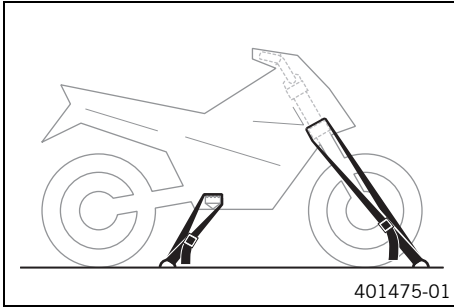

- Switch off the engine.
- Use tension belts or other suitable devices to secure the motorcycle against falling over or rolling away.

10.11 Refueling



Danger

Fire hazard Fuel is highly flammable.

The fuel in the fuel tank expands when warm and can escape if overfilled.

- Do not refuel the vehicle in the vicinity of open flames or lit cigarettes.
- Switch off the engine for refueling.
- Make sure that no fuel is spilled; particularly not on hot parts of the vehicle.
- If any fuel is spilled, wipe it off immediately.
- Observe the specifications for refueling.

**Warning**

Danger of poisoning Fuel is poisonous and a health hazard.

- Avoid skin, eye and clothing contact with fuel.
- Immediately consult a doctor if you swallow fuel.
- Do not inhale fuel vapors.
- In case of skin contact, rinse the affected area with plenty of water.
- Rinse the eyes thoroughly with water, and consult a doctor in case of fuel contact with the eyes.
- Change your clothing in case of fuel spills on them.

Note

Material damage Inadequate fuel quality causes the fuel filter to quickly become clogged.

In some countries and regions, the available fuel quality and cleanliness may not be sufficient. This will result in problems with the fuel system.

- Refuel only with clean fuel that meets the specified standards. (Your authorized KTM workshop will be glad to help.)

**Warning**

Environmental hazard Improper handling of fuel is a danger to the environment.

- Do not allow fuel to enter the groundwater, the soil, or the sewage system.
-

10 RIDING INSTRUCTIONS

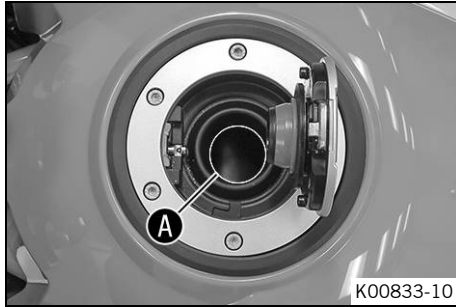

- Switch off the engine.
- Open the filler cap. (📖 p. 53)
- Fill the fuel tank with fuel up to the lower edge **A** of the filler neck.

Total fuel tank capacity, approx.	23 l (6.1 US gal)	Super unleaded (ROZ 95/RON 95/PON 91) (📖 p. 347)
-----------------------------------	----------------------	---

- Close the filler cap. (📖 p. 55)

11.1 Additional information

Any further work that results from the required work or from the recommended work must be ordered separately and can be invoiced separately.

Different service intervals may apply in your country, depending on the local operating conditions.

Individual service intervals and scopes may change in the course of technical developments. The most up-to-date service schedule can always be found on KTM Dealer.net. Your authorized KTM dealer will be happy to advise you.

11.2 Required work

	Every two years				
	Every year				
	every 30,000 km (18,600 mi)				
	every 15,000 km (9,300 mi)				
	after 1,000 km (620 mi)				
Read out the trouble code memory using the KTM diagnostics tool. 🛠️	○	●	●	●	●
Check that the electrical system is functioning properly. 🛠️	○	●	●	●	●
Change the engine oil and oil filter and clean the oil screens. 🛠️ (📖 p. 297)	○	●	●	●	●
Check the front brake linings. (📖 p. 239)	○	●	●	●	●
Check the rear brake linings. (📖 p. 244)	○	●	●	●	●
Check the brake discs. (📖 p. 234)	○	●	●	●	●
Check the brake lines for damage and leakage. 🛠️	○	●	●	●	●
Change the front brake fluid. 🛠️					●

11 SERVICE SCHEDULE

	Every two years				
	Every year				
	every 30,000 km (18,600 mi)				
	every 15,000 km (9,300 mi)				
	after 1,000 km (620 mi)				
Change the rear brake fluid. 🛠️					●
Change the hydraulic clutch fluid. 🛠️					●
Check the brake fluid level of the front brake. (📖 p. 235)	○	●	●	●	
Check the rear brake fluid level. (📖 p. 240)	○	●	●	●	
Check/correct the fluid level of the hydraulic clutch. (📖 p. 204)		●	●	●	
Check the shock absorber and fork for leaks. Perform service as needed and depending on how the vehicle is used. 🛠️	○	●	●	●	●
Clean the dust boots of the fork legs. 🛠️ (📖 p. 219)		●	●		
Check the steering head bearing play. (📖 p. 206)	○	●	●	●	●
Check the tire condition. (📖 p. 258)	○	●	●	●	●
Check the tire air pressure. (📖 p. 261)	○	●	●	●	●
Retighten the spokes. 🛠️	○				
Check the spoke tension. (📖 p. 262)		●	●	●	●
Check the rim run-out. 🛠️	○	●	●	●	●
Check the chain, rear sprocket, and engine sprocket. (📖 p. 201)		●	●	●	●
Check the chain tension. (📖 p. 198)	○	●	●	●	●
Change the spark plugs (air filter removed). 🛠️			●		

	Every two years				
	Every year				
	every 30,000 km (18,600 mi)				
	every 15,000 km (9,300 mi)				
	after 1,000 km (620 mi)				
Check the valve clearance (air filter and spark plugs removed). 🛠️			•		
Change the SAS membrane. 🛠️			•		
Check the cables for damage and routing without sharp bends. (fuel tank removed) 🛠️		•	•	•	•
Check the coolant level in the compensating tank. (📖 p. 289)	○	•	•	•	•
Change the air filter, clean the air filter box. 🛠️		•	•		
Check the fuel pressure. 🛠️		•	•	•	•
Check the CO adjustment using the KTM diagnostics tool. 🛠️	○	•	•		
Check the headlight setting. (📖 p. 285)	○	•	•		
Check that the radiator fan is functioning properly. 🛠️	○	•	•	•	•
Final check: Check the vehicle is roadworthy and take a test ride. 🛠️	○	•	•	•	•
Read out the error memory after the test ride using the KTM diagnostics tool. 🛠️	○	•	•	•	•
Set the service interval display. 🛠️	○	•	•	•	•
Make the service entry in KTM Dealer.net and in the Service and Manufacturer Warranty Booklet. 🛠️	○	•	•	•	•

- One-time interval
- Periodic interval

11 SERVICE SCHEDULE

11.3 Recommended work

		Every four years			
		Every year			
		every 30,000 km (18,600 mi)			
		every 15,000 km (9,300 mi)			
		after 1,000 km (620 mi)			
Check the frame. 🛠️			•		
Check the swingarm. 🛠️			•		
Check/clean the oil nozzle for clutch lubrication. 🛠️	○	•	•		
Check the swingarm bearing for play. 🛠️		•	•		
Check the wheel bearing for play. 🛠️		•	•		
Grease all moving parts (e.g., side stand, hand lever, chain, ...) and check for smooth operation. 🛠️	○	•	•	•	•
Empty the drainage hoses. 🛠️	○	•	•	•	•
Check all hoses (e.g. fuel, cooling, bleeder, drainage, etc.) and sleeves for cracking, leaks, and incorrect routing. 🛠️		•	•	•	•
Check the screws and nuts for tightness. 🛠️	○	•	•	•	•
Check the antifreeze. 🛠️	○	•	•	•	
Change the coolant. 🛠️					•

- One-time interval
- Periodic interval

12.1 Fork/shock absorber

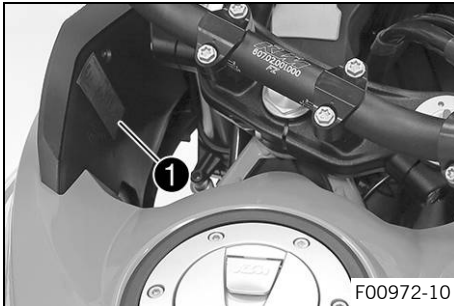

The fork and the shock absorber offer many options of adapting the suspension to the riding style and the payload.

i Info

The recommendations for the suspension setting are shown in table 1. The table is found on the left inside cover.

These adjustments are guidelines and should always be the basis for a suspension setting. If the guidelines are not adhered to, the riding characteristics could deteriorate, particularly at high speeds.

12.2 Adjusting the compression damping of the fork

i Info

The hydraulic compression damping determines the fork suspension behavior.

12 SUSPENSION SETTING



- Turn white adjusting screw ① clockwise as far as it will go.

i **Info**

Adjusting screw ① is located at the upper end of the left fork leg.
The compression damping is located in left fork leg **COMP** (white adjusting screw). The rebound damping is located in right fork leg **REB** (red adjusting screw).

-
- Turn counterclockwise by the number of clicks corresponding to the fork type.

Guideline

Compression damping	
Comfort	17 clicks
Standard	12 clicks
Sport	7 clicks
Full payload	7 clicks

i **Info**

Turn clockwise to increase damping; turn counterclockwise to reduce damping.

12.3 Adjusting the rebound damping of the fork



Info

The hydraulic rebound damping determines the fork suspension behavior.



- Turn red adjusting screw **1** clockwise as far as it will go.



Info

Adjusting screw **1** is located at the upper end of the right fork leg.

The rebound damping is located in right fork leg **REB** (red adjusting screw). The compression damping is located in left fork leg **COMP** (white adjusting screw).

- Turn counterclockwise by the number of clicks corresponding to the fork type.

Guideline

Rebound damping	
Comfort	17 clicks
Standard	12 clicks
Sport	7 clicks
Full payload	7 clicks



Info

Turn clockwise to increase damping; turn counterclockwise to reduce damping.

12.4 Adjusting the spring pretension of the fork

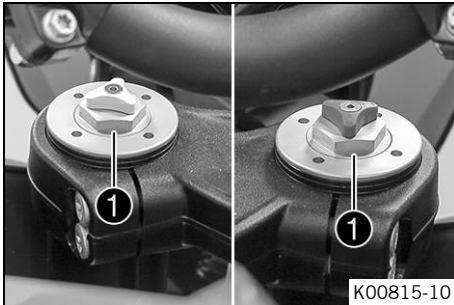

- Turn adjusting screws **1** counterclockwise all the way.



Info

Make the same adjustment on both fork legs.

- Turn clockwise by the number of turns corresponding to the fork type.

Guideline

Spring preload - Preload Adjuster	
Comfort	2 turns
Standard	5 turns
Sport	5 turns
Full payload	8 turns

**Info**

Turn clockwise to increase the spring pretension; turn counterclockwise to reduce the spring preload. Adjusting the spring pretension has no influence on the absorption setting of the rebound damping. Basically, however, you should set the rebound damping higher with a higher spring pretension.



12.5 Compression damping of the shock absorber

The compression damping of the shock absorber is divided into two ranges: high-speed and low-speed.

High-speed and low-speed refer to the compression speed of the rear wheel suspension and not to the vehicle speed.

The high-speed setting, for example, has an effect when riding over an asphalt edge: the rear wheel suspension compresses quickly.

The low-speed setting, for example, has an effect when riding over long ground swells: the rear wheel suspension compresses slowly.

These two ranges can be adjusted separately, although the transition between high-speed and low-speed is gradual. Thus, changes in the high-speed range affect the compression damping in the low-speed range and vice versa.

12.6 Adjusting the low-speed compression damping of the shock absorber



Caution

Risk of injury Parts of the shock absorber will move around if the shock absorber is detached incorrectly. The shock absorber is filled with highly compressed nitrogen.

- Please follow the description provided. (Your authorized KTM workshop will be glad to help.)



Info

The effect of the low-speed setting can be seen in slow to normal compression of the shock absorber.

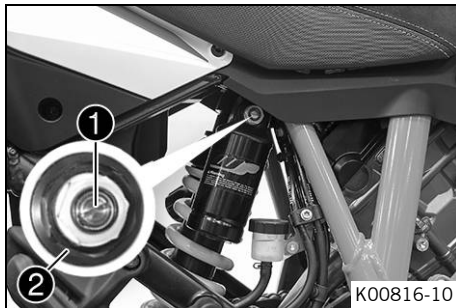

- Turn adjusting screw **1** clockwise with a screwdriver up to the last perceptible click.



Info

Do not loosen fitting **2**!

- Turn counterclockwise by the number of clicks corresponding to the shock absorber type.

Guideline

Compression damping, low-speed	
Comfort	20 clicks
Standard	15 clicks
Sport	10 clicks
Full payload	10 clicks



Info

Turn clockwise to increase damping; turn counterclockwise to reduce damping.



12.7 Adjusting the high-speed compression damping of the shock absorber



Caution

Risk of injury Parts of the shock absorber will move around if the shock absorber is detached incorrectly. The shock absorber is filled with highly compressed nitrogen.

- Please follow the description provided. (Your authorized KTM workshop will be glad to help.)



Info

The effect of the high-speed setting can be seen in fast compression of the shock absorber.

12 SUSPENSION SETTING

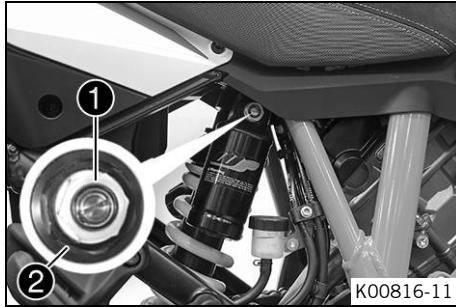

- Turn adjusting screw ① all the way clockwise with a socket wrench.



Info

Do not loosen fitting ②!

- Turn counterclockwise by the number of turns corresponding to the shock absorber type.

Guideline

Compression damping, high-speed	
Comfort	1.5 turns
Standard	1.5 turns
Sport	1 turn
Full payload	1 turn



Info

Turn clockwise to increase damping; turn counterclockwise to reduce damping.

12.8 Adjusting the rebound damping of the shock absorber



Caution

Risk of injury Parts of the shock absorber will move around if the shock absorber is detached incorrectly. The shock absorber is filled with highly compressed nitrogen.

- Please follow the description provided. (Your authorized KTM workshop will be glad to help.)

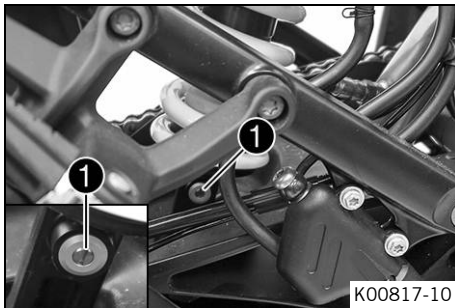

- Turn adjusting screw ❶ clockwise up to the last perceptible click.
- Turn counterclockwise by the number of clicks corresponding to the shock absorber type.

Guideline

Rebound damping	
Comfort	20 clicks
Standard	15 clicks
Sport	10 clicks
Full payload	10 clicks



Info

Turn clockwise to increase damping; turn counterclockwise to reduce damping.

12.9 Adjusting the spring pretension of the shock absorber

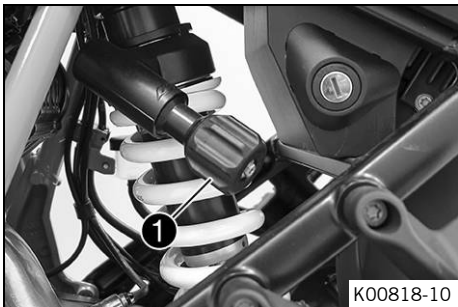

- Turn handwheel ① counterclockwise as far as it will go.
- Turn it clockwise by the number of turns corresponding to the shock absorber type and use.

Guideline

Spring preload	
Comfort	12 turns
Standard	12 turns
Sport	12 turns
Full payload	18 turns



Info

Turn clockwise to increase the spring pretension; turn counterclockwise to reduce the spring pretension.

13.1 Raising the vehicle with the center stand

Note

Material damage The vehicle may be damaged by incorrect procedure when parking. Significant damage may be caused if the vehicle rolls away or falls over. The components for parking the vehicle are designed only for the weight of the vehicle.

- Park the vehicle on a firm and level surface.
- Ensure that nobody sits on the vehicle when the vehicle is parked on a stand.

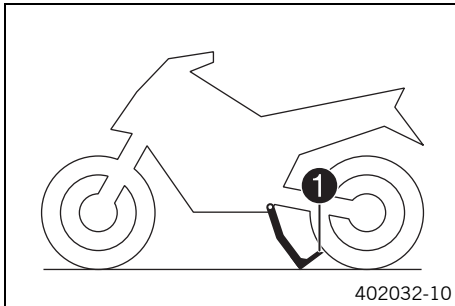

- Stand to the left of the vehicle.
 - Hold the handlebar with your left hand and push the center stand onto the ground with your right foot.
 - Put your entire weight on arm ❶ of the center stand while pulling the vehicle up at the left grab handle.
- ✓ The center stand is folded out to the stop.



13 SERVICE WORK ON THE CHASSIS

13.2 Removing the vehicle from the center stand

Note

Danger of damage The parked vehicle can roll away or fall over.

- Park the vehicle on a firm and level surface.

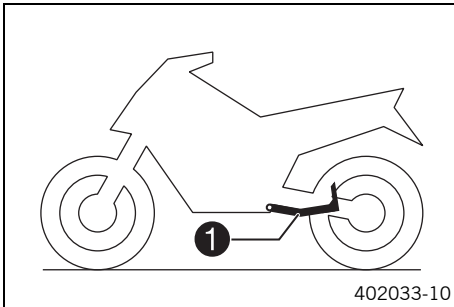

- Make sure that the steering is unlocked.
- Move the vehicle forward with both hands on the handlebar.
- While the vehicle tips off the center stand, actuate the front brake to stop the vehicle from rolling away.
- Check that the center stand ❶ is folded all the way up.

13.3 Removing the seat

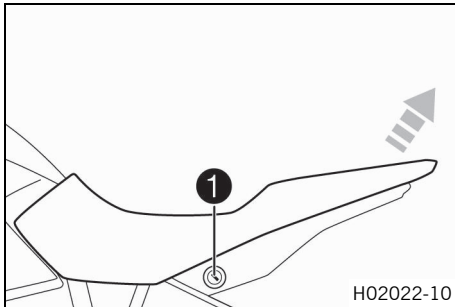

- Insert the Race-on key or the black ignition key into the seat lock **1** and turn clockwise.
- Raise the rear of the seat, pull the seat back, and lift it off.
- Remove the key.



13.4 Mounting the seat

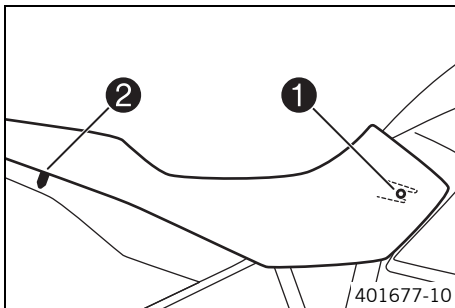

- Hook the catch **1** of the seat onto the fuel tank, lower the rear and push it forward.
- Insert locking pin **2** into the lock housing and push down the rear of the seat until the locking pin engages with a click.
- Check that the seat is correctly mounted.



13 SERVICE WORK ON THE CHASSIS

13.5 Checking for chain dirt

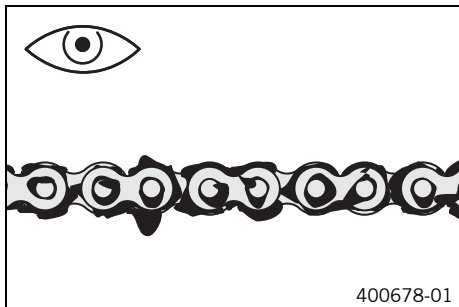

- Check the chain for coarse dirt accumulation.
 - » If the chain is very dirty:
 - Clean the chain. (📖 p. 196)

13.6 Cleaning the chain



Warning

Danger of accidents Oil or grease on the tires reduces the road grip.

- Remove the lubricant from the tires using a suitable cleaning agent.



Warning

Danger of accidents Oil or grease on the brake discs reduces the braking effect.

- Always keep the brake discs free of oil and grease.
- Clean the brake discs with brake cleaner when necessary.



Warning

Environmental hazard Hazardous substances cause environmental damage.

- Dispose of oils, grease, filters, fuel, cleaning agents, brake fluid, etc., correctly and in compliance with the applicable regulations.



Info

The service life of the chain depends largely on its maintenance.

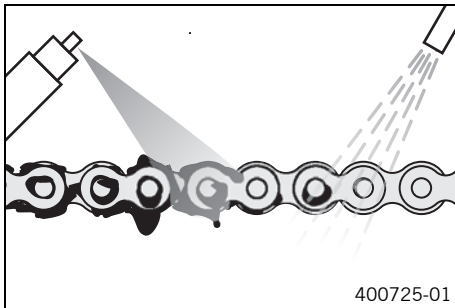

Preparatory work

- Raise the vehicle with the center stand. (📖 p. 193)

Main work

- Rinse off loose dirt with a soft jet of water.
- Remove old grease residue with chain cleaner.

Chain cleaner (📖 p. 348)

- After drying, apply chain spray.

Chain lube for road use (📖 p. 348)

Finishing work

- Remove the vehicle from the center stand. (📖 p. 194)



13.7 Checking the chain tension



Warning

Danger of accidents Incorrect chain tension damages components and results in accidents.

If the chain is tensioned too much, the chain, engine sprocket, rear sprocket, transmission and rear wheel bearings wear more quickly. Some components may break if overloaded.

If the chain is too loose, the chain may fall off the engine sprocket or the rear sprocket. As a result, the rear wheel locks or the engine will be damaged.

- Check the chain tension regularly.
- Set the chain tension in accordance with the specification.

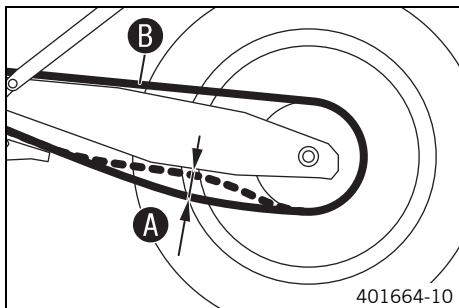

Preparatory work

- Raise the vehicle with the center stand. (📖 p. 193)

Main work

- Shift the transmission to idle **N**.
- In the area in front of the chain guide, push the chain up and determine chain tension **A**.



Info

The upper part of the chain **B** must be taut. Chain wear is not always even, so you should repeat this measurement at different chain positions.

Chain tension	40 ... 45 mm (1.57 ... 1.77 in)
---------------	---------------------------------

- » If the chain tension does not meet the specification:
 - Adjust the chain tension. (📖 p. 199)

Finishing work

- Remove the vehicle from the center stand. (📖 p. 194)



13.8 Adjusting the chain tension



Warning

Danger of accidents Incorrect chain tension damages components and results in accidents.

If the chain is tensioned too much, the chain, engine sprocket, rear sprocket, transmission and rear wheel bearings wear more quickly. Some components may break if overloaded.

If the chain is too loose, the chain may fall off the engine sprocket or the rear sprocket. As a result, the rear wheel locks or the engine will be damaged.

- Check the chain tension regularly.
- Set the chain tension in accordance with the specification.

Preparatory work

- Raise the vehicle with the center stand. (📖 p. 193)
- Check the chain tension. (📖 p. 198)

13 SERVICE WORK ON THE CHASSIS

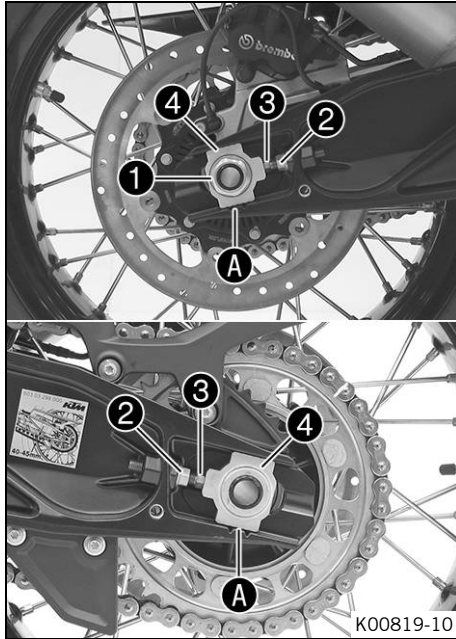

Main work

- Loosen nut ❶.
- Loosen nuts ❷.
- Adjust the chain tension by turning adjusting screws ❸ left and right.

Guideline

Chain tension	40 ... 45 mm (1.57 ... 1.77 in)
Turn the adjusting screws ❸ on the left and right so that the markings on the left and right chain adjusters ❹ are in the same position relative to the reference marks ❶. The rear wheel is then correctly aligned.	

Info

The upper part of the chain must be taut. Chain wear is not always even, so you should check the setting at different chain positions.

- Tighten nuts ❷.
- Make sure that chain adjusters ❹ are fitted correctly on adjusting screws ❸.
- Tighten nut ❶.

Guideline

Nut, rear wheel spindle	M25x1.5	90 Nm (66.4 lbf ft) Thread greased
-------------------------	---------	---------------------------------------



Info

Chain adjusters ④ can be turned by 180°.

Finishing work

- Remove the vehicle from the center stand. (📖 p. 194)



13.9 Checking the chain, rear sprocket, and engine sprocket

Preparatory work

- Raise the vehicle with the center stand. (📖 p. 193)

Main work

- Check the rear sprocket and engine sprocket for wear.
 - » If the rear sprocket and engine sprocket are worn:
 - Change the drivetrain kit. 🛠️



Info

The engine sprocket, rear sprocket and chain should always be replaced together.

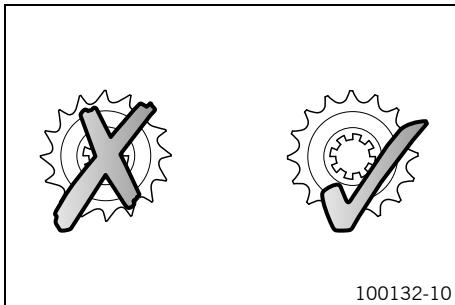

13 SERVICE WORK ON THE CHASSIS

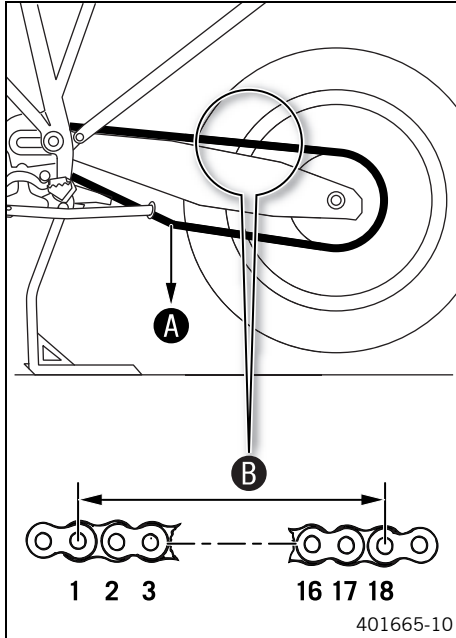

- Shift the transmission to idle **N**.
- Pull the lower chain section with specified weight **A**.

Guideline

Weight, chain wear measurement	15 kg (33 lb.)
--------------------------------	----------------

- Measure the distance **B** of 18 chain rollers on the upper part of the chain.



Info

Chain wear is not always even, so you should repeat this measurement at different chain positions.

Maximum distance B from 18 chain rollers at the longest chain section	272 mm (10.71 in)
--	-------------------

- » If distance **B** is greater than the specified measurement:
 - Change the drivetrain kit. 🛠️



Info

When a new chain is mounted, the rear sprocket and engine sprocket should also be changed. New chains wear out faster on old, worn sprockets. For safety reasons, the chain has no chain joint.

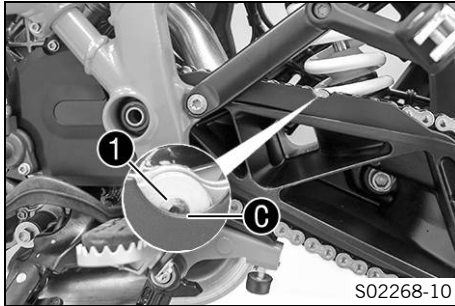

- Check the chain sliding guard for wear at the recess.



Info

When the chain sliding guard is new, the rivets **1** are half visible at the bottom edge **C** of the recess.

- » When the rivets of the chain are no longer visible at the bottom edge of the recess of the chain sliding guard:
 - Change the chain sliding guard. 🛠️
- Check that the chain sliding guard is firmly seated.
 - » If the chain sliding guard is loose:
 - Tighten the screws on the chain sliding guard.

Guideline

Screw, chain sliding guard	M5	5 Nm (3.7 lbf ft)
----------------------------	----	-------------------

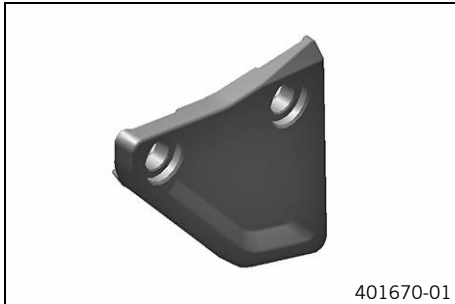

- Check the chain guide for wear.
 - » If the chain guide is worn:
 - Change the chain guide. 🛠️
- Check that the chain guide is firmly seated.
 - » If the chain guide is loose:
 - Tighten the screws on the chain guide.

Guideline

Screw, chain guide	M6	5 Nm (3.7 lbf ft)
--------------------	----	-------------------

Finishing work

- Remove the vehicle from the center stand. (📖 p. 194)

13.10 Checking/correcting the fluid level of the hydraulic clutch

Info

The fluid level rises with increasing wear of the clutch facing discs.

Never use DOT 5 brake fluid. It is silicone-based and purple in color. Oil seals and clutch lines are not designed for DOT 5 brake fluid.

Avoid contact between brake fluid and painted parts. Brake fluid attacks paint.

Only use clean brake fluid from a sealed container.

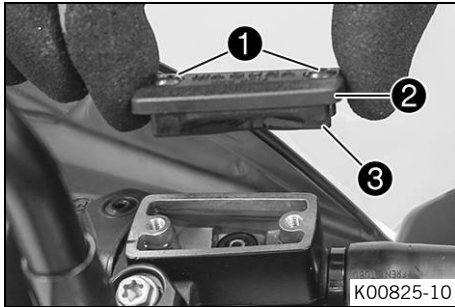

- Move the clutch fluid reservoir mounted on the handlebar to a horizontal position.
- Remove screws ①.
- Remove cover ② with membrane ③.
- Check the fluid level.

Fluid level below container rim	4 mm (0.16 in)
---------------------------------	----------------

- » If the fluid level does not meet specifications:
 - Correct the fluid level of the hydraulic clutch.

Brake fluid DOT 4 / DOT 5.1 (📖 p. 344)
--

- Position the cover with the membrane. Mount and tighten the screws.



Info

Clean up overflowed or spilled brake fluid immediately with water.



13.11 Checking the steering head bearing play



Warning

Danger of accidents Incorrect steering head bearing play impairs the handling characteristic and damages components.

- Correct incorrect steering head bearing play immediately. (Your authorized KTM workshop will be glad to help.)



Info

If the vehicle is operated for a lengthy period with play in the steering head bearing, the bearings and the bearing seats in the frame can become damaged over time.

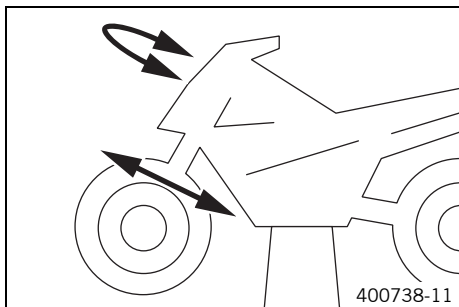

Preparatory work

- Raise the vehicle with the center stand. (📖 p. 193)

Main work

- Place a load on the rear of the vehicle.
 - ✓ The front wheel is not in contact with the ground.
- Move the handlebar to the straight-ahead position. Move the fork legs back and forth in the direction of travel.

Play should not be detectable on the steering head bearing.

- » If there is no detectable play:
 - Adjust the steering head bearing play. 🛠️
- Move the handlebar to and fro over the entire steering range.

It must be possible to move the handlebar easily over the entire steering range. There should be no detectable detent positions.

- » If detent positions are detected:
 - Adjust the steering head bearing play. 🛠️
 - Check the steering head bearing and adjust if necessary.

Finishing work

- Remove the vehicle from the center stand. (📖 p. 194)



13.12 Removing the bottom triple clamp cover

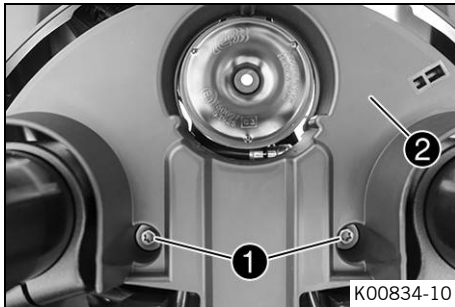

- Remove screws ①.
- Lower triple clamp cover ② slightly.

13 SERVICE WORK ON THE CHASSIS

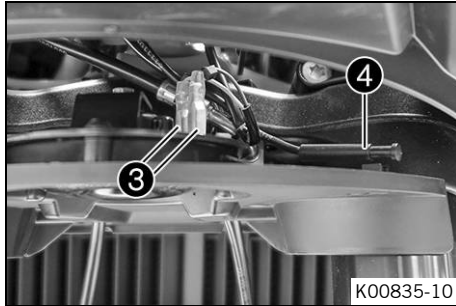

- Disconnect plugs **3** of the horn.
- Detach temperature sensor **4**.
- Remove the triple clamp cover.

13.13 Installing the bottom triple clamp cover

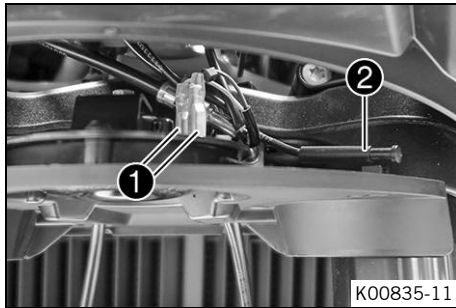

- Plug in connectors **1** of the horn.
- Attach temperature sensor **2**.

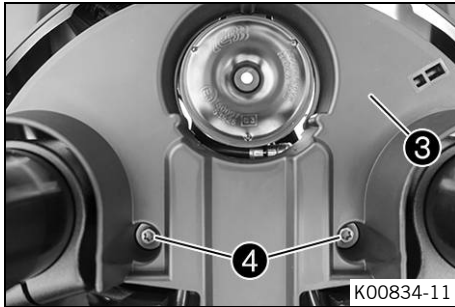

- Position the triple clamp cover ③.
- Mount and tighten screws ④.

Guideline

Remaining chassis screws	M6	10 Nm (7.4 lbf ft)
--------------------------	----	--------------------

13.14 Removing the front side cover



- Remove screws ①.
- Remove side cover ②.
- Repeat these steps on the opposite side.

13 SERVICE WORK ON THE CHASSIS

13.15 Installing the front side cover

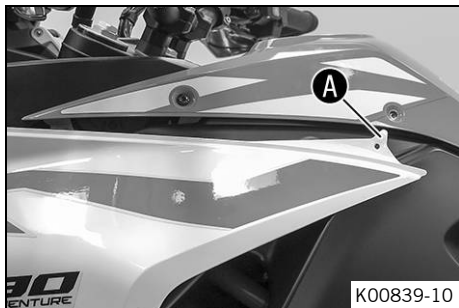

- Position the side cover in the area **A** under the tank cover.

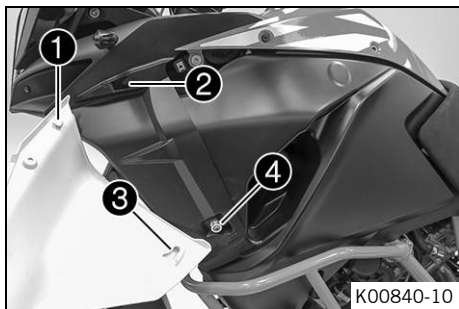

- Attach side cover to bracket **2** using the catch **1**.
- Attach catch **3** of the side cover to bracket **4** and position on the fuel tank.



- Mount and tighten screws ⑤.

Guideline

Screw, cover part	M5x12	3.5 Nm (2.58 lbf ft)
-------------------	-------	-------------------------

- Repeat these steps on the opposite side.



13.16 Removing the mask spoiler 🛠️

Preparatory work

- Remove the seat. (📖 p. 195)
- Remove the front side cover. (📖 p. 209)
- Remove the tank cover. (📖 p. 220)

13 SERVICE WORK ON THE CHASSIS

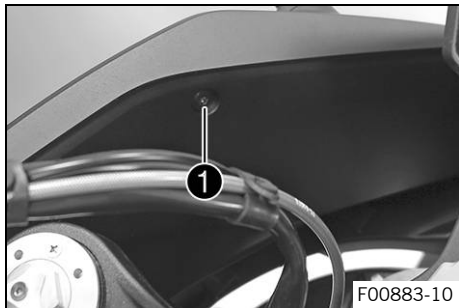

Main work

- Remove screw ①.

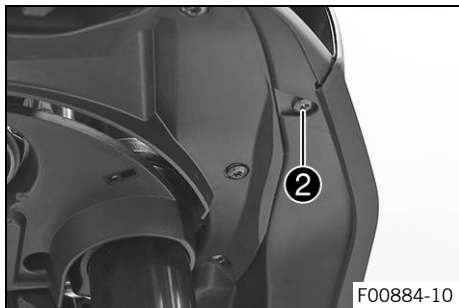

- Remove screw ②.

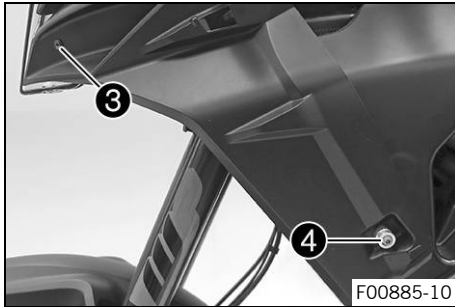

- Remove screw ③.
- Remove screw ④ with the bushing.

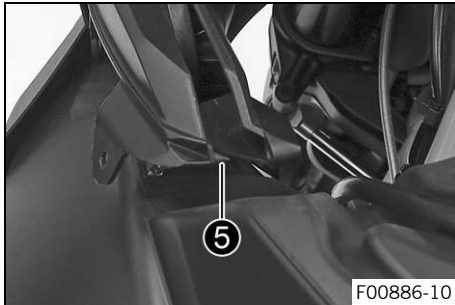

- Loosen holding lug ⑤ from the inside cover.

13 SERVICE WORK ON THE CHASSIS

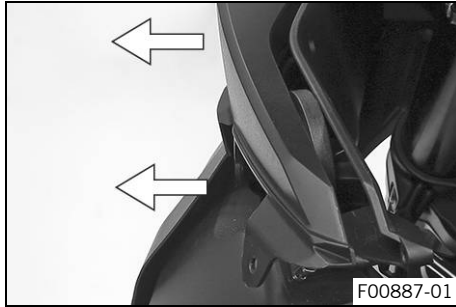

- Remove the mask spoiler laterally from the supports.



Info

Pay attention to the turn signal cable.

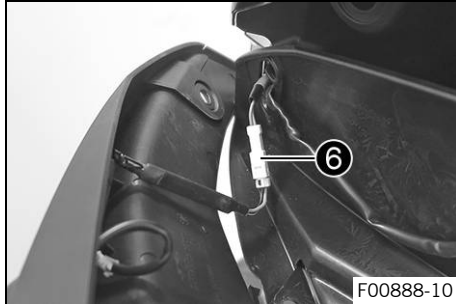

- Disconnect plug-in connector **6**.
- Remove the mask spoiler with the turn signal.
- Repeat these steps on the opposite side.

13.17 Installing the mask spoiler ↩

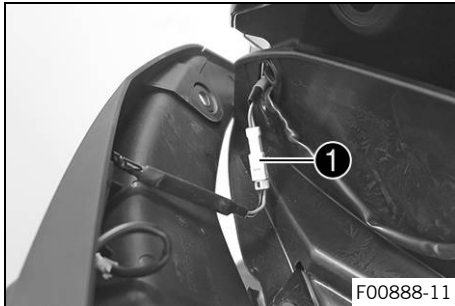

Main work

- Connect plug-in connector ①.

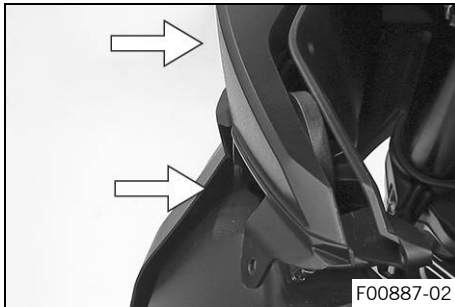

- Position the mask spoiler and press laterally into the supports.



Info

Ensure that the turn signal cable is placed correctly.

13 SERVICE WORK ON THE CHASSIS

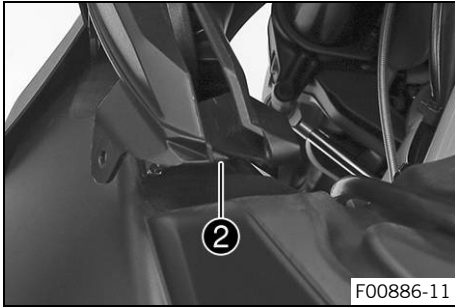

- Position holding lug ② in the drill hole.

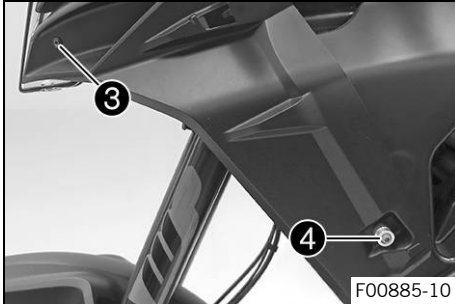

- Mount and tighten screw ③.

Guideline

Screw, mask spoiler	M5x17	3.5 Nm (2.58 lbf ft)
---------------------	-------	-------------------------

- Mount and tighten screw ④ with the bushing.

Guideline

Screw, bushing	M6	4 Nm (3 lbf ft)
----------------	----	-----------------

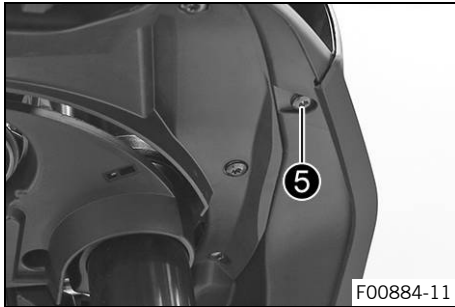

- Mount and tighten screw ⑤.

Guideline

Screw, mask spoiler	M5x17	3.5 Nm (2.58 lbf ft)
---------------------	-------	-------------------------

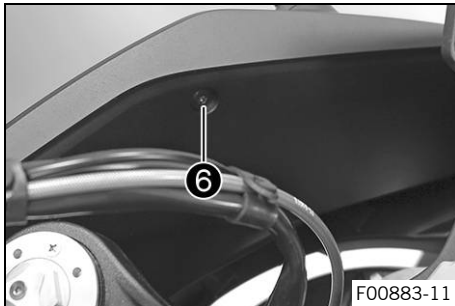

- Mount and tighten screw ⑥.

Guideline

Screw, mask spoiler	M5x17	3.5 Nm (2.58 lbf ft)
---------------------	-------	-------------------------

- Repeat these steps on the opposite side.

Finishing work

- Install the tank cover. (📖 p. 223)
- Install the front side cover. (📖 p. 210)
- Mount the seat. (📖 p. 195)



13 SERVICE WORK ON THE CHASSIS

13.18 Removing front fender

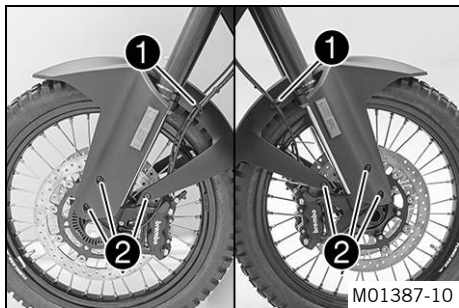

- Open holder **1** and detach the brake lines and cable.
- Remove screws **2**.
- Take the fender off to the front.



Info

Pay attention to the brake lines and the cable.

13.19 Installing front fender

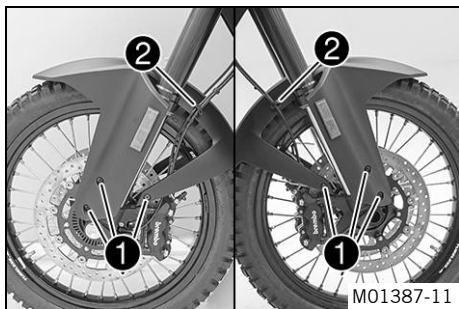

- Position the fender.



Info

Pay attention to the routing of the brake lines and the cable.

- Mount and tighten screws **1**.

Guideline

Screw, fender	M5x12	3.5 Nm (2.58 lbf ft)
---------------	-------	-------------------------

- Insert the brake lines and cable in brackets ② and close the holder.



13.20 Cleaning the dust boots of the fork legs

Preparatory work

- Raise the vehicle with the center stand. (📖 p. 193)
- Remove front fender. (📖 p. 218)

Main work

- Push dust boots ① of both fork legs downward.

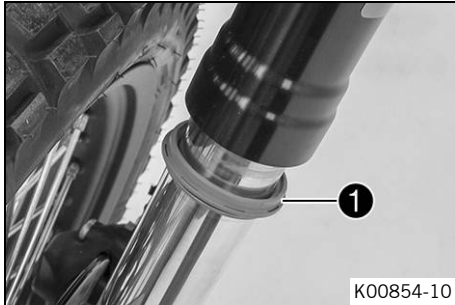

Info

The dust boots should remove dust and coarse dirt particles from the fork tubes. Over time, dirt can accumulate behind the dust boots. If this dirt is not removed, the oil seals behind can start to leak.



Warning

Danger of accidents Oil or grease on the brake discs reduces the braking effect.

- Always keep the brake discs free of oil and grease.
- Clean the brake discs with brake cleaner when necessary.

13 SERVICE WORK ON THE CHASSIS

- Clean and oil the dust boots and inner fork tubes of both fork legs.

Universal oil spray (📖 p. 349)

- Press dust boots ① back into their installation position.
- Remove excess oil.

Finishing work

- Install front fender. (📖 p. 218)
- Remove the vehicle from the center stand. (📖 p. 194)

13.21 Removing the tank cover

Preparatory work

- Remove the seat. (📖 p. 195)
- Remove the front side cover. (📖 p. 209)

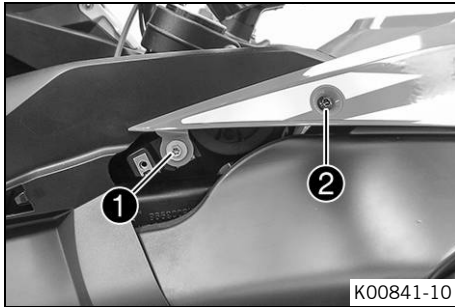

Main work

- Remove screw ①.
- Remove screw ②.

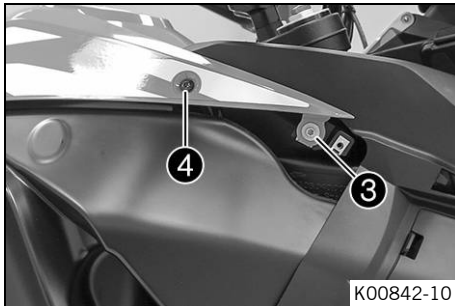

- Remove screw ③.
- Remove screw ④.

13 SERVICE WORK ON THE CHASSIS

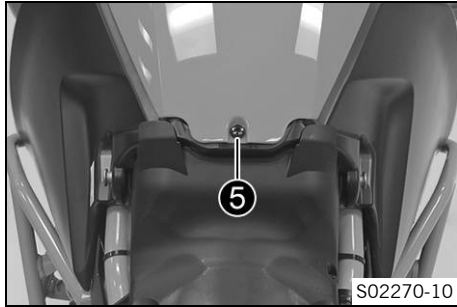

- Remove screw 5.



- Raise the tank cover at the rear and take it off in a forward direction.

13.22 Installing the tank cover

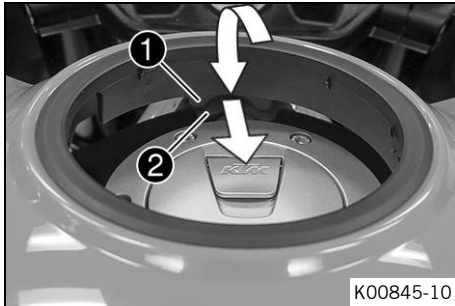

Main work

- Position the tank cover.
- ✓ The catch ① engages under the tank ②.



Info

Pay attention to the sealing lip and the bleeder hose.

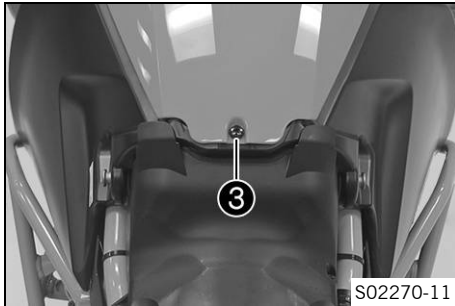

- Mount and tighten screw ③.

Guideline

Screw, cover part	M5x12	3.5 Nm (2.58 lbf ft)
-------------------	-------	-------------------------

13 SERVICE WORK ON THE CHASSIS

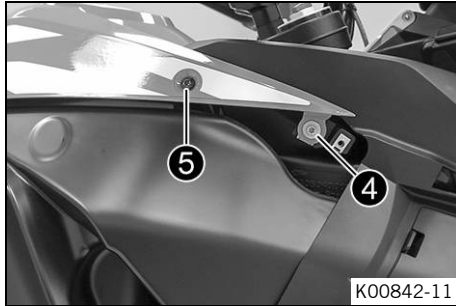

- Mount and tighten screw ④.

Guideline

Screw, cover part	M6	6 Nm (4.4 lbf ft)
-------------------	----	-------------------

- Mount and tighten screw ⑤.

Guideline

Screw, cover part	M5x12	3.5 Nm (2.58 lbf ft)
-------------------	-------	-------------------------

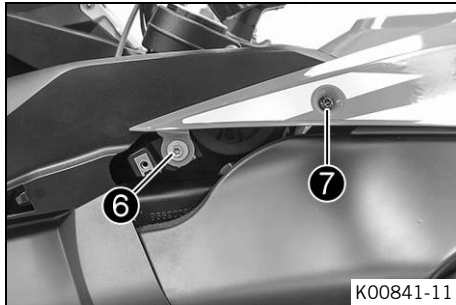

- Mount and tighten screw ⑥.

Guideline

Screw, cover part	M6	6 Nm (4.4 lbf ft)
-------------------	----	-------------------

- Mount and tighten screw ⑦.

Guideline

Screw, cover part	M5x12	3.5 Nm (2.58 lbf ft)
-------------------	-------	-------------------------

Finishing work

- Install the front side cover. (📖 p. 210)
- Mount the seat. (📖 p. 195)

13.23 Removing the wind shield

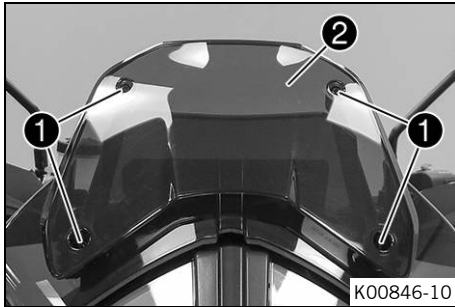

- Remove screws **1** and wind shield **2**.

13.24 Installing the wind shield

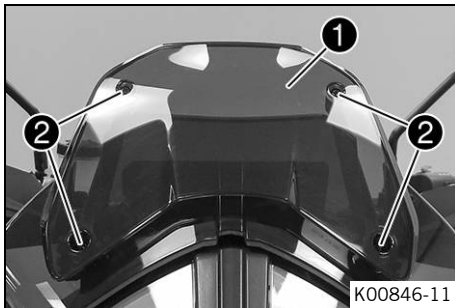

- Position wind shield **1**.
- Mount and tighten screws **2**.

Guideline

Screw, wind shield	M5	3.5 Nm (2.58 lbf ft)
--------------------	----	-------------------------

13 SERVICE WORK ON THE CHASSIS

13.25 Removing the engine guard

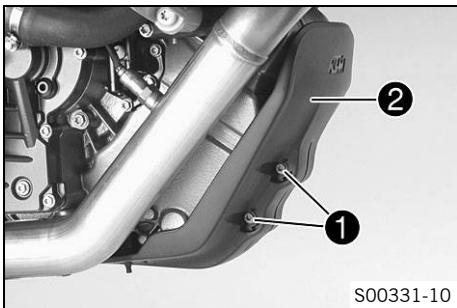

- Remove screws ① with bushings and engine guard ②.

13.26 Installing the engine guard

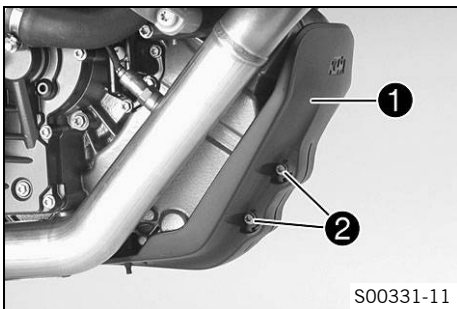

- Position engine guard ①, mount screws ② with bushings and tighten.

Guideline

Screw, engine guard	M6	10 Nm (7.4 lbf ft)
---------------------	----	--------------------

13.27 Removing the crash bar

Preparatory work

- Raise the vehicle with the center stand. ( p. 193)

Main work

- Remove fittings **1**.

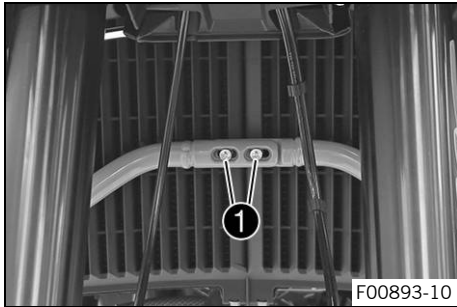

- Remove screws **2** and take off the clamp halves.
- Remove screw **3**.
- Remove screw **4** and take off right crash bar.

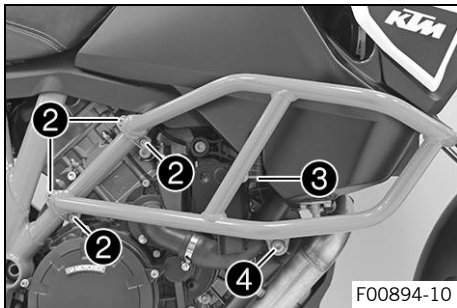

13 SERVICE WORK ON THE CHASSIS

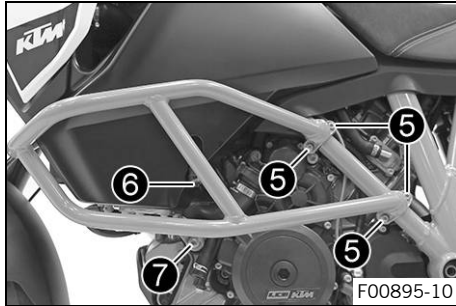

- Remove screws **5** and take off the clamp halves.
- Remove screw **6**.
- Remove screw **7** and take off left crash bar.

13.28 Installing the crash bar

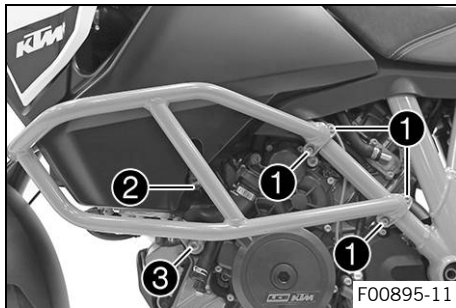

- Position the left crash bar with frame protector and attach the clamp to the frame tube.



Info

Cover the components to protect them against damage.

- Mount screws **1** but do not tighten yet.

Guideline

Remaining chassis screws	M6	10 Nm (7.4 lbf ft)
--------------------------	----	--------------------

- Mount screw **2** but do not tighten yet.

Guideline

Remaining chassis screws	M6	10 Nm (7.4 lbf ft)
--------------------------	----	--------------------

- Mount screw **3** but do not tighten yet.

Guideline

Remaining chassis screws	M10	45 Nm (33.2 lbf ft)
--------------------------	-----	---------------------

- Position the right crash bar with frame protector and attach the clamp to the frame tube.



Info

Cover the components to protect them against damage.

- Mount screws **4** but do not tighten yet.

Guideline

Remaining chassis screws	M6	10 Nm (7.4 lbf ft)
--------------------------	----	--------------------

- Mount screw **5** but do not tighten yet.

Guideline

Remaining chassis screws	M6	10 Nm (7.4 lbf ft)
--------------------------	----	--------------------

- Mount screw **6** but do not tighten yet.

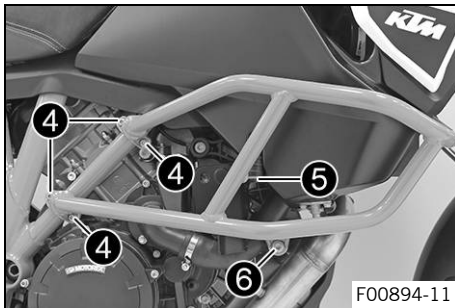

13 SERVICE WORK ON THE CHASSIS

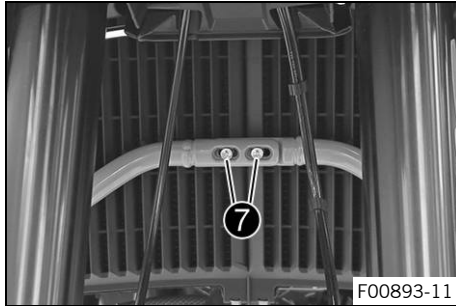

Guideline

Remaining chassis screws	M10	45 Nm (33.2 lbf ft)
--------------------------	-----	---------------------

- Mount and tighten fittings 7.

Guideline

Remaining chassis screws	M6	10 Nm (7.4 lbf ft)
--------------------------	----	--------------------

- ✓ The crash bars are equally aligned with each other.

- Tighten all the screws of the crash bar.

Guideline

Remaining chassis screws	M6	10 Nm (7.4 lbf ft)
Remaining chassis screws	M10	45 Nm (33.2 lbf ft)

14.1 Antilock brake system (ABS)

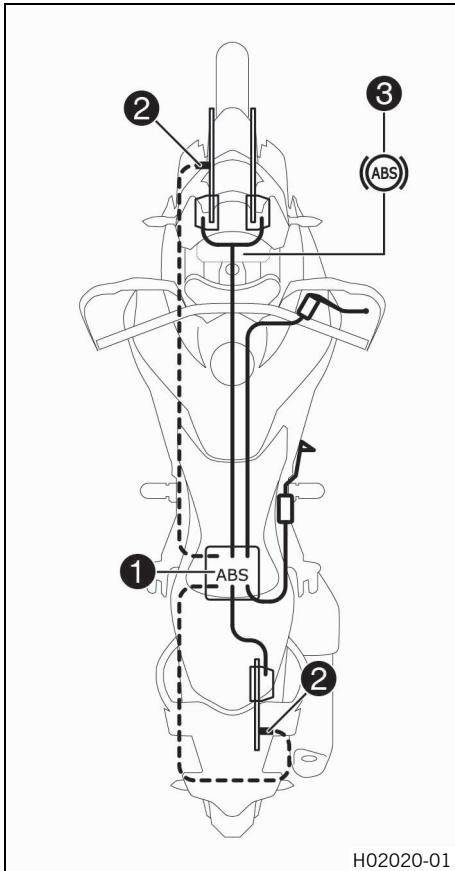

The ABS unit **1**, which consists of a hydraulic unit, brake electronics control unit, and return pump, is installed under the seat. One wheel speed sensor **2** is located in each case on the front and the rear wheel.

**Warning**

Danger of accidents Changes to the vehicle impair the function of the ABS.

- Only allow the rear wheel to spin with the front brake applied away from public road traffic if the ABS is switched off.
- Do not make any changes to the suspension travel.
- Only use spare parts on the brake system which have been approved and recommended by KTM.
- Only use tires/wheels approved by KTM with the corresponding speed index.
- Maintain the specified tire air pressure.
- Service work and repairs must be performed professionally. (Your authorized KTM workshop will be glad to help.)

ABS is a safety system that prevents locking of the wheels when driving straight ahead without the influence of lateral forces.



Warning

Danger of accidents Driving aids can only prevent a rollover within the physical limitations.

It is not always possible to compensate for extreme riding situations, for example with luggage loaded with a high center of gravity, varying road surfaces, steep descents or full braking without disengaging the gear.

- Adapt your riding style to the road conditions and your driving ability.

ABS has two operating modes: the **Road** and **Offroad** ABS modes. In the **Road** ABS mode, the brakes are also applied to the rear wheel when the front brake is applied. ABS can intervene on both wheels.

In the **Offroad** ABS mode, the front brake slows the front wheel. The rear brake slows the rear wheel. There is no ABS intervention on the rear wheel. The ABS indicator lamp  flashes slowly to remind you that the **Offroad** ABS mode is enabled.



Info

In the **Offroad** ABS mode, the rear wheel may lock and there is a risk of falling.

The ABS operates with two independent brake circuits (front and rear brakes). When the brake electronics control unit detects a

locking tendency in a wheel, ABS begins regulating the brake pressure. The regulating process causes a slight pulsing of the hand and foot brake levers.

The ABS indicator lamp **3** must light up after the ignition is switched on and go out after starting off. If it does not go out after starting off or if it is lit while riding, this indicates a fault in the ABS. In this case, the ABS is no longer enabled and the wheels may lock during braking. The brake system itself stays functional; only ABS control is not available.

The ABS indicator lamp may also light up if the rotating speeds of the front and rear wheels differ greatly under extreme riding conditions, for example when making "wheelies" or if the rear wheel spins. This causes the ABS to switch off.

To reactivate the ABS, stop the vehicle and switch off the ignition. The ABS is reactivated when the vehicle is switched on again. The ABS indicator lamp goes out when you start off.

MSC

The **MSC** is a supplementary function for the ABS that can prevent blocking and slipping of the wheels during braking when the vehicle is inclined (riding in curves) within the physical limitations. By means of the 5D sensor, ABS control is now dependent on the inclination and pitch angle.

ABS control that is dependent on the inclination and pitch angle improves the riding stability and braking effect in all riding situations. The **MSC** also reduces the righting moment during hard braking in curves. This prevents the motorcycle from righting itself from an inclined angle and moving along a larger curve radius.

Due to the additional electronic control of the brake force distribution between the two wheels, the braking force is optimally distributed and the motorcycle is additionally stabilized.



Info

The **MSC** is only active in **Road** ABS mode.

14.2 Checking the brake discs



Warning

Danger of accidents Worn-out brake discs reduce the braking effect.

- Make sure that worn-out brake discs are replaced immediately. (Your authorized KTM workshop will be glad to help.)

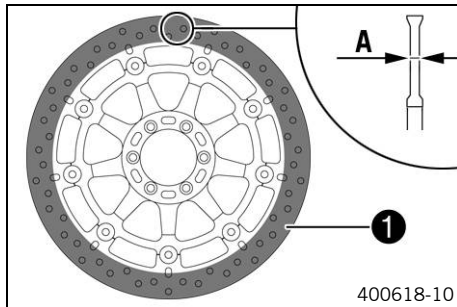

- Check the front and rear brake disc thickness at multiple points for the dimension **A**.



Info

Wear will reduce the thickness of the brake disc at contact surface **1** of the brake linings.

Brake discs - wear limit

front	4 mm (0.16 in)
rear	4.5 mm (0.177 in)

- » If the brake disc thickness is less than the specified value.
 - Change the front brake discs. 🛠️
 - Change the rear brake disc. 🛠️
- Check the front and rear brake discs for damage, cracking, and deformation.
 - » If the brake disc exhibits damage, cracking, or deformation:
 - Change the front brake discs. 🛠️
 - Change the rear brake disc. 🛠️



14.3 Checking the brake fluid level of the front brake



Warning

Danger of accidents An insufficient brake fluid level will cause the brake system to fail.

If the brake fluid level drops below the **MIN** marking, the brake system is leaking or the brake linings are worn down.

- Check the brake system and do not continue riding until the problem is eliminated. (Your authorized KTM workshop will be glad to help.)

14 BRAKE SYSTEM



Warning

Danger of accidents Old brake fluid reduces the braking effect.

- Make sure that brake fluid for the front and rear brake is changed in accordance with the service schedule. (Your authorized KTM workshop will be glad to help.)

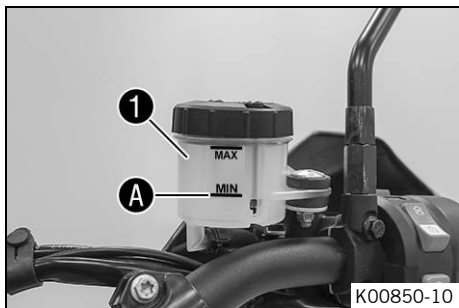

- Move the brake fluid reservoir mounted on the handlebar to a horizontal position.
- Check the brake fluid level in the brake fluid reservoir **1**.
 - » If the brake fluid has dropped below marking **MIN A**:
 - Add front brake fluid. 🗨️ (p. 236)

14.4 Adding front brake fluid 🗨️



Warning

Danger of accidents An insufficient brake fluid level will cause the brake system to fail.

If the brake fluid level drops below the **MIN** marking, the brake system is leaking or the brake linings are worn down.

- Check the brake system and do not continue riding until the problem is eliminated. (Your authorized KTM workshop will be glad to help.)

**Warning**

Skin irritation Brake fluid causes skin irritation.

- Keep brake fluid out of the reach of children.
- Wear suitable protective clothing and safety glasses.
- Do not allow brake fluid to come into contact with the skin, the eyes or clothing.
- Consult a doctor immediately if brake fluid has been swallowed.
- Rinse the affected area with plenty of water in the event of contact with the skin.
- Rinse eyes thoroughly with water immediately and consult a doctor if brake fluid comes into contact with the eyes.
- If brake fluid spills on to your clothing, change the clothing.

**Warning**

Danger of accidents Old brake fluid reduces the braking effect.

- Make sure that brake fluid for the front and rear brake is changed in accordance with the service schedule. (Your authorized KTM workshop will be glad to help.)

**Warning**

Environmental hazard Hazardous substances cause environmental damage.

- Dispose of oils, grease, filters, fuel, cleaning agents, brake fluid, etc., correctly and in compliance with the applicable regulations.
-

i Info

Never use DOT 5 brake fluid. It is silicone-based and purple in color. Oil seals and brake lines are not designed for DOT 5 brake fluid.

Avoid contact between brake fluid and painted parts. Brake fluid attacks paint.

Only use clean brake fluid from a sealed container.

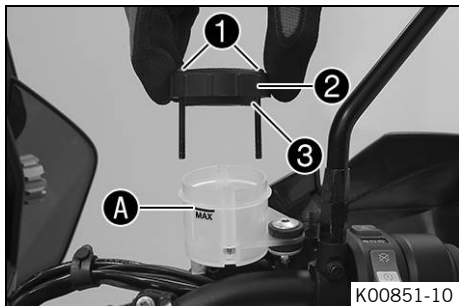

Preparatory work

- Check the front brake linings. (📖 p. 239)

Main work

- Move the brake fluid reservoir mounted on the handlebar to a horizontal position.
- Remove screws ①.
- Remove cover ② with membrane ③.
- Add brake fluid up to **MAX** marking A.

Brake fluid DOT 4 / DOT 5.1 (📖 p. 344)

- Position cover ② with membrane ③.
- Mount and tighten screws ①.

i Info

Clean up overflowed or spilled brake fluid immediately with water.

14.5 Checking the front brake linings



Warning

Danger of accidents Worn-out brake linings reduce the braking effect.

- Ensure that worn-out brake linings are replaced immediately. (Your authorized KTM workshop will be glad to help.)



Warning

Danger of accidents Damaged brake discs reduce the braking effect.

If the brake linings are not changed in time, the brake lining carriers grind against the brake disc. As a consequence, the braking effect is greatly reduced and the brake discs are destroyed.

- Check the brake linings regularly.

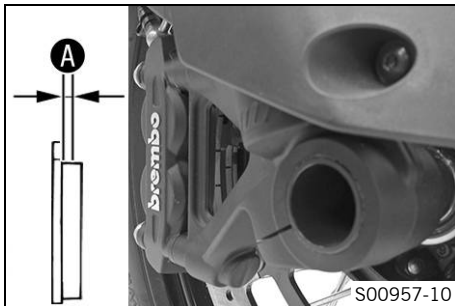

- Check all brake linings on both brake calipers to ensure they have minimum thickness **A**.

Minimum thickness A	$\geq 1 \text{ mm } (\geq 0.04 \text{ in})$
----------------------------	---

- » If the minimum thickness is less than specified:
 - Change the front brake linings. 🛠️
- Check all brake linings on both brake calipers for damage and cracking.
 - » If there is wear or tearing:
 - Change the front brake linings. 🛠️

14.6 Checking the rear brake fluid level



Warning

Danger of accidents An insufficient brake fluid level will cause the brake system to fail.

If the brake fluid level drops below the **MIN** marking, the brake system is leaking or the brake linings are worn down.

- Check the brake system and do not continue riding until the problem is eliminated. (Your authorized KTM workshop will be glad to help.)



Warning

Danger of accidents Old brake fluid reduces the braking effect.

- Make sure that brake fluid for the front and rear brake is changed in accordance with the service schedule. (Your authorized KTM workshop will be glad to help.)

Preparatory work

- Raise the vehicle with the center stand. (📖 p. 193)

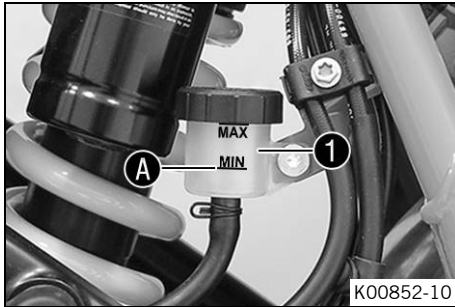

Main work

- Check the brake fluid level in the brake fluid reservoir **1**.
 - » If the fluid level reaches the **MIN** marking **A**:
 - Add rear brake fluid. 🛠️ (📖 p. 241)



14.7 Adding rear brake fluid 🛠️



Warning

Danger of accidents An insufficient brake fluid level will cause the brake system to fail.

If the brake fluid level drops below the **MIN** marking, the brake system is leaking or the brake linings are worn down.

- Check the brake system and do not continue riding until the problem is eliminated. (Your authorized KTM workshop will be glad to help.)



Warning

Skin irritation Brake fluid causes skin irritation.

- Keep brake fluid out of the reach of children.
- Wear suitable protective clothing and safety glasses.
- Do not allow brake fluid to come into contact with the skin, the eyes or clothing.
- Consult a doctor immediately if brake fluid has been swallowed.
- Rinse the affected area with plenty of water in the event of contact with the skin.
- Rinse eyes thoroughly with water immediately and consult a doctor if brake fluid comes into contact with the eyes.
- If brake fluid spills on to your clothing, change the clothing.



Warning

Danger of accidents Old brake fluid reduces the braking effect.

- Make sure that brake fluid for the front and rear brake is changed in accordance with the service schedule. (Your authorized KTM workshop will be glad to help.)



Warning

Environmental hazard Hazardous substances cause environmental damage.

- Dispose of oils, grease, filters, fuel, cleaning agents, brake fluid, etc., correctly and in compliance with the applicable regulations.
-



Info

Never use DOT 5 brake fluid. It is silicone-based and purple in color. Oil seals and brake lines are not designed for DOT 5 brake fluid.

Avoid contact between brake fluid and painted parts. Brake fluid attacks paint.

Only use clean brake fluid from a sealed container.

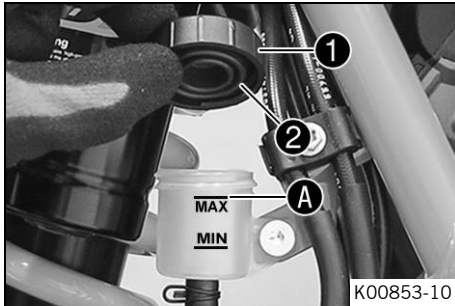

Preparatory work

- Raise the vehicle with the center stand. (📖 p. 193)
- Check the rear brake linings. (📖 p. 244)

Main work

- Remove screw cap ① with membrane ②.
- Add brake fluid up to **MAX** marking **A**.

Brake fluid DOT 4 / DOT 5.1 (📖 p. 344)

- Mount and tighten screw cap ① with membrane ②.



Info

Clean up overflowed or spilled brake fluid immediately with water.

14.8 Checking the rear brake linings



Warning

Danger of accidents Worn-out brake linings reduce the braking effect.

- Ensure that worn-out brake linings are replaced immediately. (Your authorized KTM workshop will be glad to help.)



Warning

Danger of accidents Damaged brake discs reduce the braking effect.

If the brake linings are not changed in time, the brake lining carriers grind against the brake disc. As a consequence, the braking effect is greatly reduced and the brake discs are destroyed.

- Check the brake linings regularly.

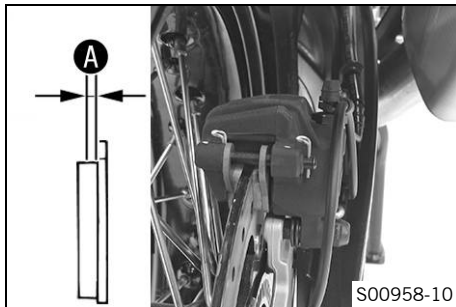

- Check the brake linings for minimum thickness **A**.

Minimum thickness A	$\geq 1 \text{ mm } (\geq 0.04 \text{ in})$
----------------------------	---

- » If the minimum thickness is less than specified:
 - Change the rear brake linings. 🛠️
- Check the brake linings for damage and cracking.
 - » If there is wear or tearing:
 - Change the rear brake linings. 🛠️

15.1 Removing the front wheel ↘

Preparatory work

- Raise the vehicle with the center stand. (📖 p. 193)

Main work

- Place a load on the rear of the vehicle.
- ✓ The front wheel is not in contact with the ground.
- Remove screw ❶ and pull wheel speed sensor ❷ out of the hole.

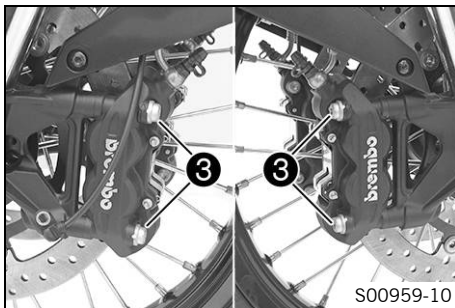
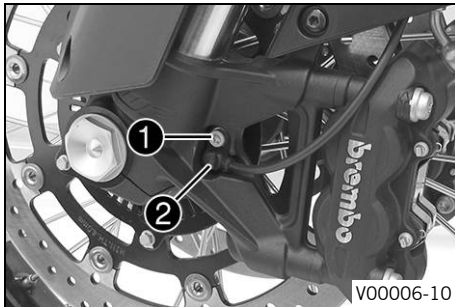

- Remove screws ❸ from both brake calipers.
- Press back the brake linings with a slight lateral tilting of the brake calipers on the brake disc.
- Pull the brake calipers carefully back from the brake discs and hang them to one side loosely.



Info

Do not pull the hand brake lever when the brake caliper has been removed.

15 WHEELS, TIRES

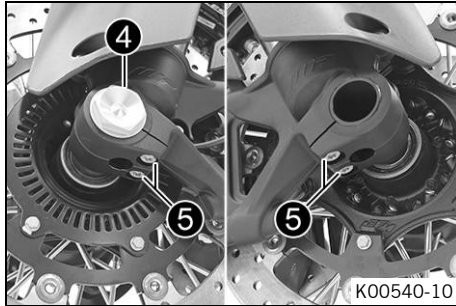

- Loosen screw 4 by several rotations.
- Loosen screws 5.
- Press on screw 4 to push the wheel spindle out of the axle clamp.
- Remove screw 4.



Warning

Danger of accidents Damaged brake discs reduce the braking effect.

- Always lay the wheel down in such a way that the brake discs are not damaged.

- Hold the front wheel and remove the wheel spindle. Take the front wheel out of the fork.



Info

Do not pull the hand brake lever when the front wheel is removed.

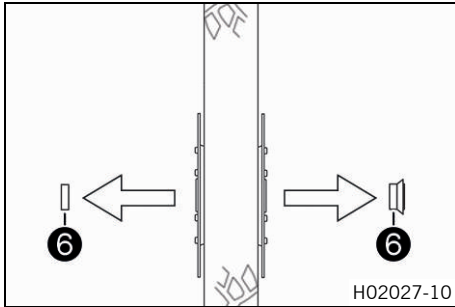

- Remove spacers ⑥.



15.2 Installing the front wheel 🐾



Warning

Danger of accidents Oil or grease on the brake discs reduces the braking effect.

- Always keep the brake discs free of oil and grease.
- Clean the brake discs with brake cleaner when necessary.

15 WHEELS, TIRES

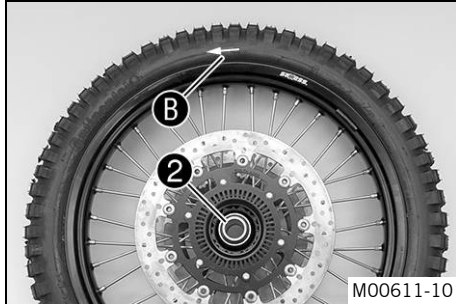
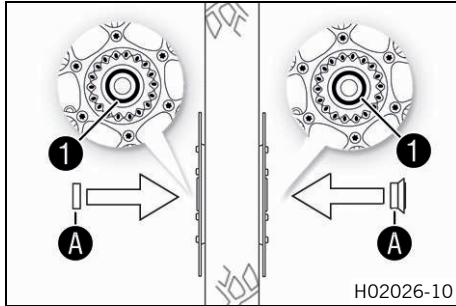

- Check the wheel bearing for damage and wear.
 - » If the wheel bearing is damaged or worn:
 - Change front wheel bearing. 🛠️
- Clean and grease shaft seal rings **1** and contact surface **A** of the spacers.

Long-life grease (📖 p. 348)

- Insert wide spacer **2** on the left in the direction of travel.

i Info

Arrow **B** indicates the direction of travel of the front wheel.
The ABS sensor wheel is on the left viewed in the direction of travel.

- Insert the narrow spacer on the right in the direction of travel.

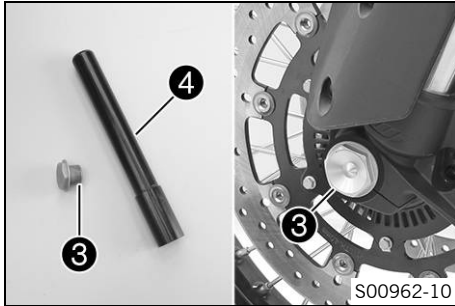

Warning

Danger of accidents Oil or grease on the brake discs reduces the braking effect.

- Always keep the brake discs free of oil and grease.
- Clean the brake discs with brake cleaner when necessary.

- Clean and grease screw **3** and wheel spindle **4**.

Long-life grease (📖 p. 348)

- Jack up the front wheel into the fork, position it, and insert the wheel spindle.
- Mount and tighten screw **3**.

Guideline

Screw, front wheel spindle	M25x1.5	45 Nm (33.2 lbf ft) Thread greased
----------------------------	---------	---------------------------------------

15 WHEELS, TIRES

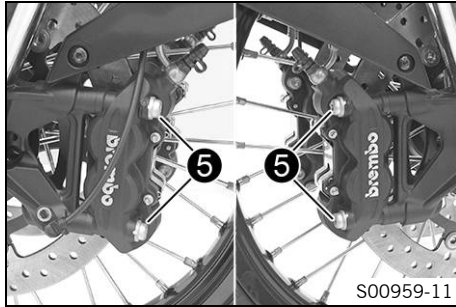

- Position the brake calipers.
 - ✓ The brake linings are correctly positioned.
- Mount screws **5** on both brake calipers but do not tighten yet.
- Operate the hand brake lever repeatedly until the brake linings are in contact with the brake disc and there is a pressure point. Fix the hand brake lever in the activated position.
 - ✓ The brake calipers straighten.
- Tighten screws **5** on both brake calipers.

Guideline

Screw, front brake caliper	M10	45 Nm (33.2 lbf ft) Loctite®243™
----------------------------	-----	--

- Remove the locking piece of the hand brake lever.
- Position wheel speed sensor **6** in the drill hole.
- Mount and tighten screw **7**.

Guideline

Remaining chassis screws	M6	10 Nm (7.4 lbf ft)
--------------------------	----	--------------------

- Remove the vehicle from the center stand. (📖 p. 194)

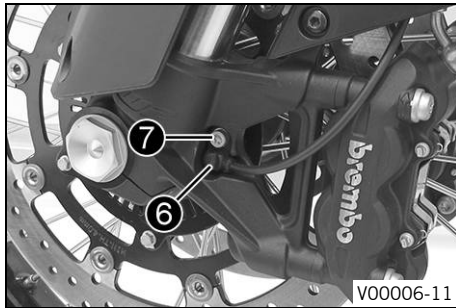

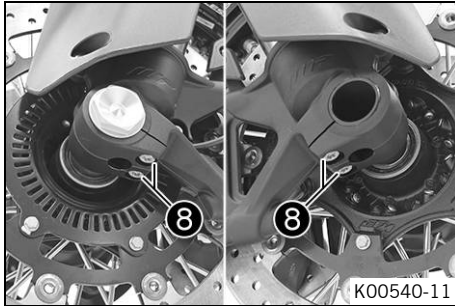

- Operate the front brake and compress the fork a few times firmly.
- ✓ The fork legs straighten.
- Tighten screws 8.

Guideline

Screw, fork stub	M8	15 Nm (11.1 lbf ft)
------------------	----	---------------------

15.3 Removing the rear wheel

Preparatory work

- Raise the vehicle with the center stand. (📖 p. 193)

Main work

- Press the brake caliper onto the brake disc by hand in order to push back the brake pistons.

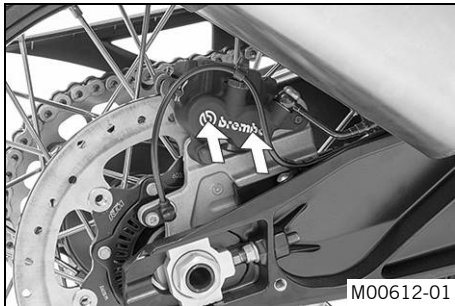

15 WHEELS, TIRES

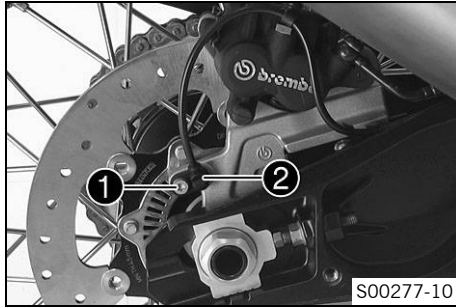

- Remove screw **1** and pull wheel speed sensor **2** out of the hole.

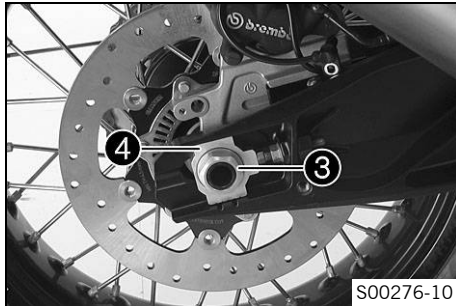

- Remove nut **3**. Remove chain adjuster **4**.

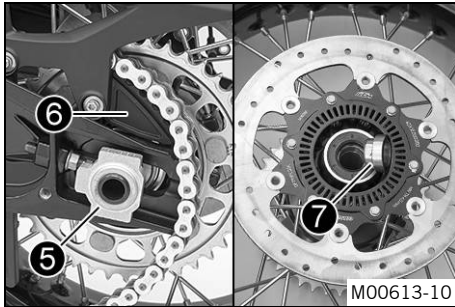

- Pull out wheel spindle **5** far enough to allow the rear wheel to be pushed forward.
- Push the rear wheel forward as far as possible. Take the chain off of the rear sprocket and place it on chain sprocket guard **6**.



Warning

Danger of accidents Reduced braking effect caused by damaged brake discs.

- Always lay the wheel down in such a way that the brake discs are not damaged.

- Holding the rear wheel, withdraw the wheel spindle. Take the rear wheel out of the swingarm.



Info

Do not operate the foot brake when the rear wheel is removed.

- Remove spacer **7**.



15.4 Installing the rear wheel 🛠️



Warning

Danger of accidents Oil or grease on the brake discs reduces the braking effect.

- Always keep the brake discs free of oil and grease.
- Clean the brake discs with brake cleaner when necessary.



Warning

Danger of accidents There is no braking effect to start with at the rear brake after installing the rear wheel.

- Actuate the foot brake several times before going on a ride until you can feel a firm pressure point.

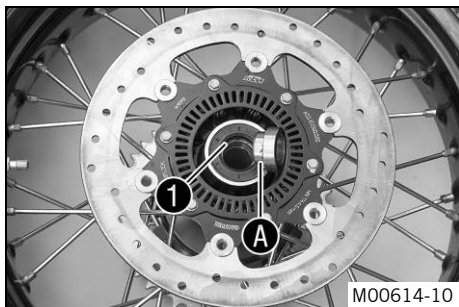

- Check the rear hub rubber dampers. 🛠️ (📖 p. 257)
- Check the wheel bearing for damage and wear.
 - » If the wheel bearing is damaged or worn:
 - Change the rear wheel bearing. 🛠️
- Clean and grease shaft seal ring **1** and contact surface **A** of the spacer.

Long-life grease (📖 p. 348)

- Insert the spacer.
- Clean and grease the thread of the wheel spindle and nut.

Long-life grease (📖 p. 348)

- Mount the rubber dampers and rear sprocket carrier on the rear wheel.
- Place the rear wheel in the swingarm and bring the brake disc into contact with the brake caliper.
- Mount wheel spindle ② but do not push it in all the way.
- Push the rear wheel forward as far as possible and lay the chain on the rear sprocket.

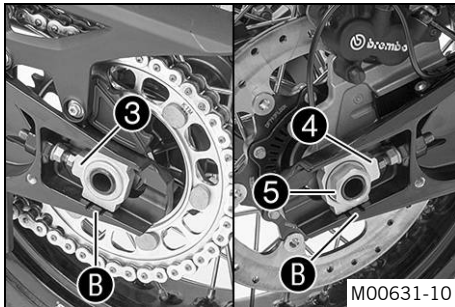
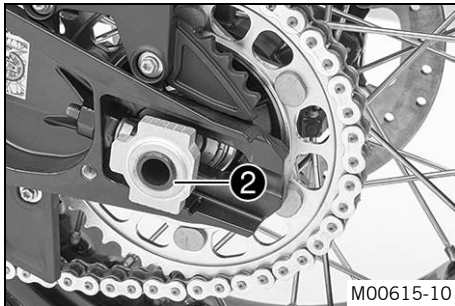

- Push the wheel spindle in all the way and mount chain adjuster ④ and nut ⑤.



Info

Mount chain adjusters ③ and ④ in the same position.

- Make sure that the chain adjusters are fitted correctly on the adjusting screws.

15 WHEELS, TIRES

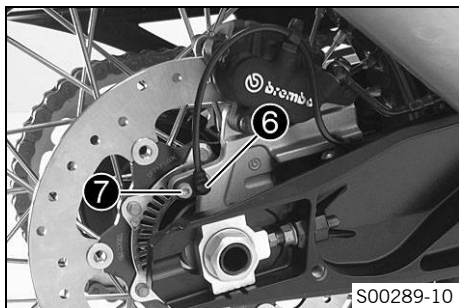

Guideline

In order for the rear wheel to be correctly aligned, the markings on the left and right chain adjusters must be in the same position relative to reference markings **B**.

- Tighten nut **5**.

Guideline

Nut, rear wheel spindle	M25x1.5	90 Nm (66.4 lbf ft) Thread greased
-------------------------	---------	---------------------------------------

- Position wheel speed sensor **6** in the drill hole.
- Mount and tighten screw **7**.

Guideline

Remaining chassis screws	M6	10 Nm (7.4 lbf ft)
--------------------------	----	--------------------

- Operate the foot brake lever repeatedly until the brake linings are in contact with the brake disc and there is a pressure point.

15.5 Checking the rear hub rubber dampers 🛠️

i Info

The engine power is transmitted from the rear sprocket to the rear wheel via 6 rubber dampers. The rubber dampers wear out during operation. If the rubber dampers are not changed in time, the rear sprocket carrier and the rear hub will be damaged.

Preparatory work

- Raise the vehicle with the center stand. (📖 p. 193)
- Remove the rear wheel. 🛠️ (📖 p. 251)

Main work

- Check the rubber dampers ❶ of the rear hub for damage and wear.
 - » If the rubber dampers of the rear hub are damaged or worn:
 - Change all rubber dampers in the rear hub. 🛠️

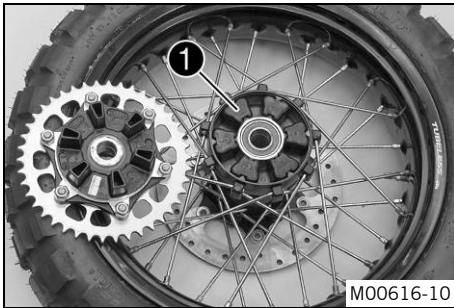

15 WHEELS, TIRES

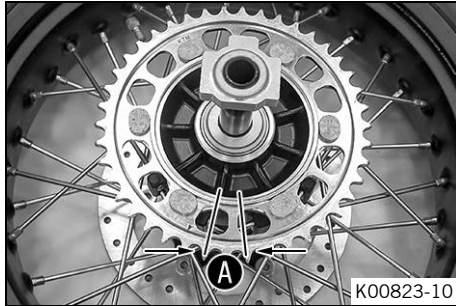

- Lay the rear wheel on a workbench with the rear sprocket facing upwards and insert the wheel spindle in the hub.
- Check the rear sprocket play **A**.



Info

Measure the play on the outside of the rear sprocket.

Play in rubber dampers, rear wheel	$\leq 5 \text{ mm } (\leq 0.2 \text{ in})$
------------------------------------	--

- » If clearance **A** is larger than the specified value:
 - Change all rubber dampers in the rear hub. 🛠️

Finishing work

- Install the rear wheel. 🛠️ (📖 p. 254)

15.6 Checking the tire condition



Warning

Danger of accidents If a tire bursts while riding, the vehicle becomes uncontrollable.

- Ensure that damaged or worn tires are replaced immediately. (Your authorized KTM workshop will be glad to help.)



Warning

Danger of crashing Different tire tread patterns on the front and rear wheel impair the handling characteristic.

Different tire tread patterns can make the vehicle significantly more difficult to control.

- Make sure that only tires with a similar tire tread pattern are fitted to the front and rear wheel.



Warning

Danger of accidents Non-approved or non-recommended tires and wheels impact the handling characteristic.

- Only use tires/wheels approved by KTM with the corresponding speed index.



Warning

Danger of accidents New tires have reduced road grip.

The contact surface on new tires is not yet roughened.

- Run in new tires with moderate riding at alternating angles.
Running-in phase 200 km (124 mi)



Info

Tire type, tire condition, and tire air pressure influence the braking and handling characteristics of the vehicle.

Worn tires are particularly unfavorable on wet surfaces.

15 WHEELS, TIRES

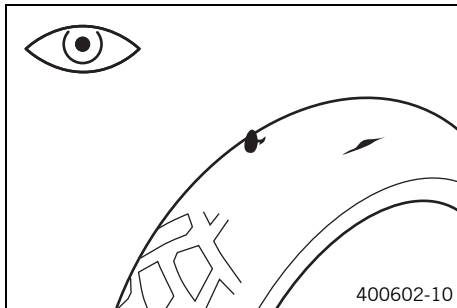

- Check the front and rear tires for cuts, run-in objects, and other damage.
 - » If the tires have cuts, run-in objects, or other damage:
 - Change the tires. 🛠️
- Check the tread depth.



Info

Adhere to the legally required minimum tread depth.

Minimum tread depth	$\geq 2 \text{ mm } (\geq 0.08 \text{ in})$
---------------------	---

- » If the tread depth is less than the minimum tread depth:
 - Change the tires. 🛠️

- Check the tire age.



Info

The tire date of manufacture is usually contained in the tire label and is indicated by the last four digits of the **DOT** number. The first two digits indicate the week of manufacture and the last two digits the year of manufacture.

KTM recommends that the tires be changed after 5 years at the latest, regardless of the actual state of wear.

- » If the tires are more than 5 years old:

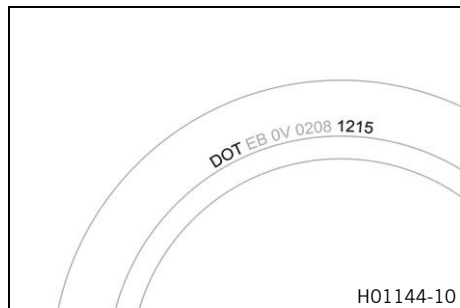

- Change the tires. 🐞



15.7 Checking the tire air pressure



Info

Low tire air pressure leads to abnormal wear and overheating of the tire.
Correct tire air pressure ensures optimal riding comfort and maximum tire service life.

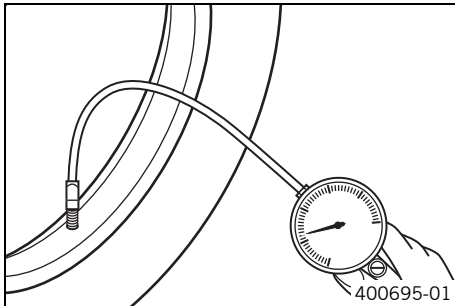

- Remove the dust cap.
- Check the tire air pressure when the tires are cold.

Tire air pressure, solo/with passenger/full payload	
front: with cold tires	2.6 bar (38 psi)
rear: with cold tires	2.9 bar (42 psi)

- » If the tire pressure does not meet specifications:
 - Correct the tire pressure.
- Mount the dust cap.



15.8 Checking spoke tension



Warning

Danger of accidents Incorrectly tensioned spokes impair the handling characteristic and result in secondary damage.

The spokes break due to being overloaded if they are too tightly tensioned. If the tension in the spokes is too low, then lateral and radial run-out will form in the wheel. Other spokes will become looser as a result.

- Check spoke tension regularly, and in particular on a new vehicle. (Your authorized KTM workshop will be glad to help.)

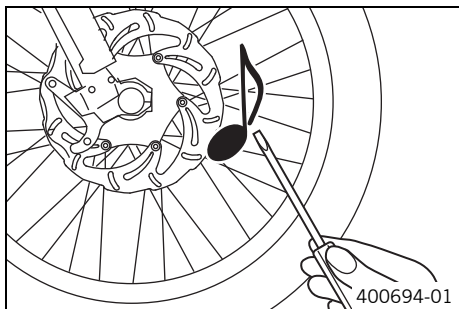

- Strike each spoke briefly using a screwdriver blade.

Info

The frequency of the sound depends on the spoke length and spoke diameter. If spokes of the same length and diameter vibrate with a different tone, this is an indication that the spoke tensions differ.

You should hear a high note.

- » If the spoke tension differs:
 - Correct the spoke tension. 🛠️

15.9 Tubeless tire system

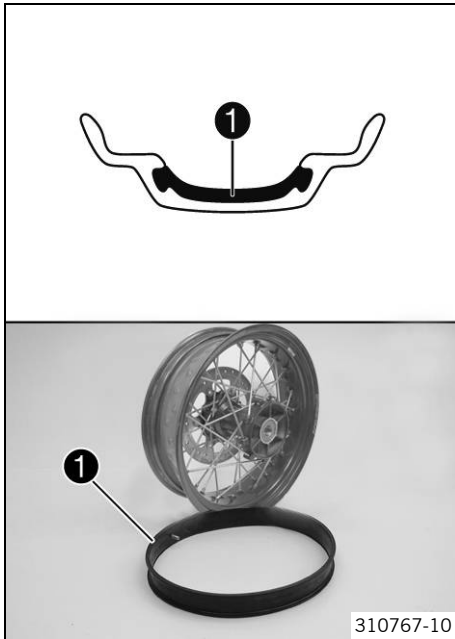

This vehicle makes use of a tubeless tire system in which a tubeless sealing profile ❶ is used instead of the conventional tube. The advantage of the tubeless system is that there is no risk of a defective tube. This greatly reduces the risk of a sudden loss in pressure.

The masses and moments of inertia of these wheels are smaller than in conventional spoke wheels with a tube. This results in better handling and riding comfort.

The rigid rim design results in a spoke wheel that is almost entirely maintenance-free.

KTM recommends that the tubeless sealing profile be changed after 5 years at the latest, regardless of the actual state of wear.

16.1 Daytime running light (DRL)

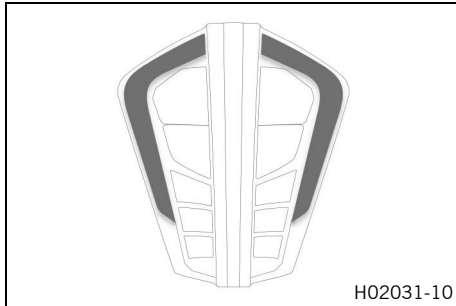

Warning

Danger of accidents When visibility is poor, the daytime running light is not a substitute for the low beam.

Automatic switching between the daytime running light and low beam may only be partially available when visibility is significantly impaired due to fog, snow or rain.

- Ensure that the appropriate type of lighting is always selected.
- If necessary switch off the daytime running lights using the menu before going on a ride or when stopped so that the low beam is switched on permanently.
- Note the legal regulations regarding the daytime running light.

The daytime running (DRL)/position light is integrated in the main headlight. The daytime running light is brighter than the position light.

The daytime running light must only be switched on when visibility conditions are good.

Control is provided by the brightness sensor in the combination instrument. When visibility conditions are good, the low beam

with position light is switched off and the daytime running light is switched on.
 When the daytime running light is switched off, the low beam with position light lights up.
 On high beam or headlight flasher, the daytime running light changes automatically to the position light.

16.2 Cornering headlight

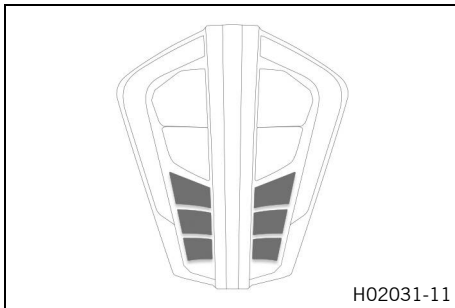

The cornering headlights are integrated in the main headlight.

i Info

To activate the cornering light, the low beam must be switched on and the daytime running light switched off.

The cornering headlights are activated with:

Lean angle for the lower LED	$\geq 12^\circ$
Lean angle for the middle LED	$\geq 20^\circ$
Lean angle for the upper LED	$\geq 28^\circ$
Speed	$\geq 6 \text{ km/h}$ ($\geq 3.7 \text{ mph}$)

16.3 Removing the battery ↵



Warning

Risk of injury Battery acid and battery gases cause serious chemical burns.

- Keep batteries out of the reach of children.
- Wear suitable protective clothing and safety glasses.
- Avoid contact with battery acid and battery gases.
- Keep sparks or open flames away from the battery.
- Only charge batteries in well-ventilated rooms.
- Rinse the affected area immediately with plenty of water in the event of contact with the skin.
- Rinse eyes with water for at least 15 minutes and consult a doctor immediately if battery acid and battery gases get into the eyes.





Caution

Danger of accidents Electronic components and safety devices will be damaged if the battery is discharged or missing.

- Never operate the vehicle with a discharged battery or without a battery.

Preparatory work

- Switch off ignition - to do this briefly press the Race-on button  (maximum of 1 second) with the ignition switched on.
- Remove the seat.  p. 195

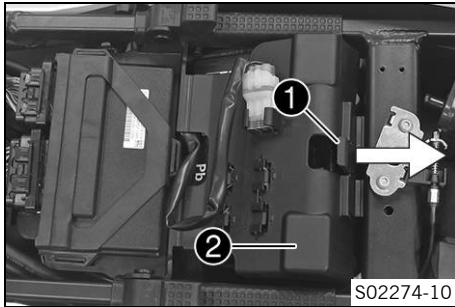

Main work

- Pull locking mechanism **1** in the direction of the arrow.
- Fold open cover **2**.

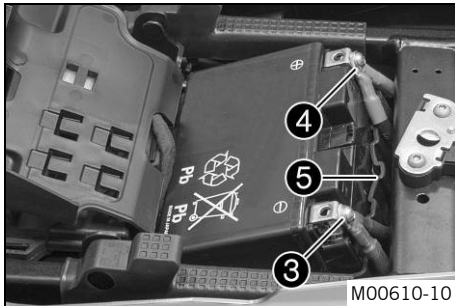

- Disconnect both negative cables **3** from the battery.
- Disconnect both positive cables **4** from the battery.
- Take the battery and battery case **5** out of the battery compartment.

16.4 Installing the battery ↴



Warning

Risk of injury Battery acid and battery gases cause serious chemical burns.

- Keep batteries out of the reach of children.
- Wear suitable protective clothing and safety glasses.
- Avoid contact with battery acid and battery gases.
- Keep sparks or open flames away from the battery.
- Only charge batteries in well-ventilated rooms.
- Rinse the affected area immediately with plenty of water in the event of contact with the skin.
- Rinse eyes with water for at least 15 minutes and consult a doctor immediately if battery acid and battery gases get into the eyes.



Caution

Danger of accidents Electronic components and safety devices will be damaged if the battery is discharged or missing.

- Never operate the vehicle with a discharged battery or without a battery.

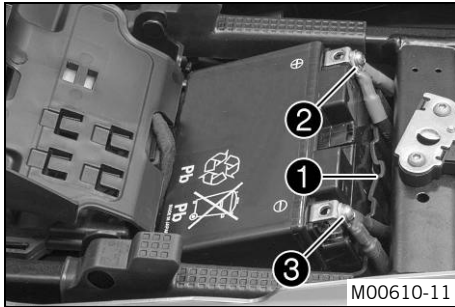

Main work

- Position the battery in battery case ①.

Guideline

The even side of the battery case must be opposite the poles.

- Position the battery and battery case in the battery compartment.
- Position the positive cable ② and mount and tighten the screw.

Guideline

Screw, battery terminal	M6	4.5 Nm (3.32 lbf ft)
-------------------------	----	-------------------------

- Position the negative cable ③ and mount and tighten the screw.

Guideline

Screw, battery terminal	M6	4.5 Nm (3.32 lbf ft)
-------------------------	----	-------------------------

16 ELECTRICAL SYSTEM

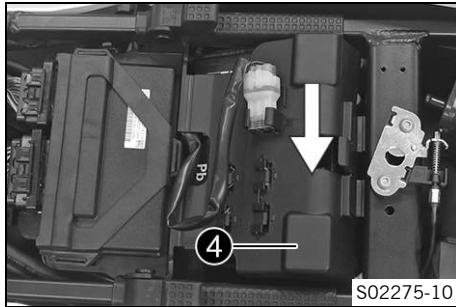

- Close the cover ④ and push down slightly.
- ✓ The cover engages with an audible click.

Finishing work

- Mount the seat. (📖 p. 195)
- Set the time and date.

16.5 Recharging the battery ↩



Warning

Risk of injury Battery acid and battery gases cause serious chemical burns.

- Keep batteries out of the reach of children.
- Wear suitable protective clothing and safety glasses.
- Avoid contact with battery acid and battery gases.
- Keep sparks or open flames away from the battery.
- Only charge batteries in well-ventilated rooms.
- Rinse the affected area immediately with plenty of water in the event of contact with the skin.
- Rinse eyes with water for at least 15 minutes and consult a doctor immediately if battery acid and battery gases get into the eyes.



Warning

Environmental hazard Batteries contain environmentally-hazardous materials.

- Do not dispose of batteries as household waste.
- Dispose of batteries at a collection point for used batteries.



Warning

Environmental hazard Hazardous substances cause environmental damage.

- Dispose of oils, grease, filters, fuel, cleaning agents, brake fluid, etc., correctly and in compliance with the applicable regulations.



Info

Even when there is no load on the battery, it discharges steadily.

The charge state and the type of charge are very important for the service life of the battery.

Rapid recharging with a high charging current shortens the service life of the battery.

If the charging current, charging voltage, and charging time are exceeded, electrolyte escapes through the safety valves. This reduces the battery capacity.

If the battery is depleted from starting the vehicle repeatedly, the battery must be charged immediately.



If the battery is left in a discharged state for an extended period, over-discharge and sulfating occurs, destroying the battery.

The battery is maintenance-free, i.e., the acid level does not have to be checked.

If the battery is not charged using the KTM battery charger, the battery must be removed for charging.

Otherwise, overvoltage may damage electronic components. Charge the battery according to the instructions on the battery housing.

Preparatory work

- Switch off ignition - to do this briefly press the Race-on button  (maximum of 1 second) with the ignition switched on.
- Remove the seat. ( p. 195)

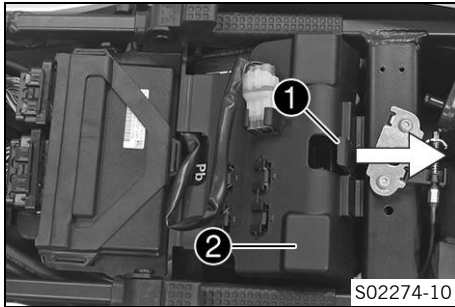

Main work

- Pull locking mechanism **1** in the direction of the arrow.
- Fold open cover **2**.

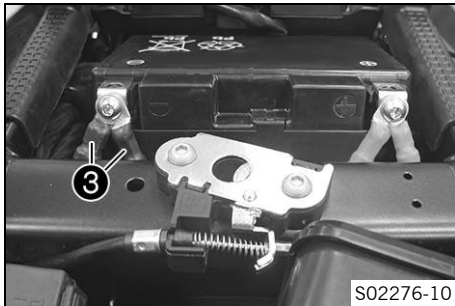

- Disconnect both negative cables **3** of the battery to avoid damage to the motorcycle's electronics.



- Connect the battery charger to the battery. Switch on the battery charger.

Battery charger (58429074000)



Info

You can also use the battery charger to test the open-circuit voltage and start potential of the battery, and to test the alternator. With this device, you cannot overcharge the battery.

Charge the battery at no more than 10 % of the capacity specified on the battery housing.

- Switch off the battery charger after charging and disconnect from the battery.

Guideline

The charging current, charging voltage, and charging time must not be exceeded.

Charge the battery regularly when the motorcycle is not in use

3 months

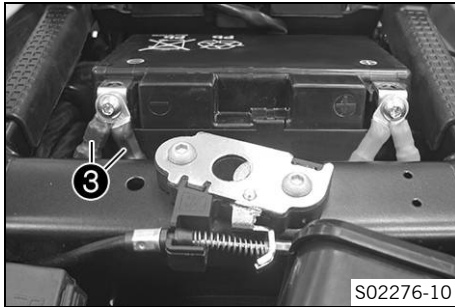

- Connect both negative cables ③ to the battery.

Guideline

Screw, battery terminal	M6	4.5 Nm (3.32 lbf ft)
-------------------------	----	-------------------------

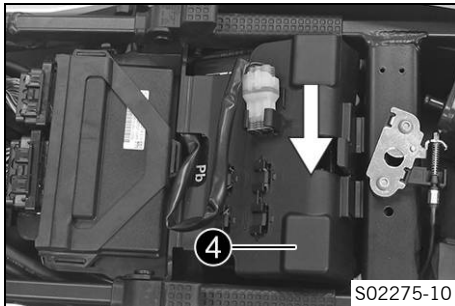

- Close cover ④ and push down slightly.
- ✓ The cover engages with an audible click.

Finishing work

- Mount the seat. (📖 p. 195)
- Set the time and date.



16.6 Changing the Race-on key battery

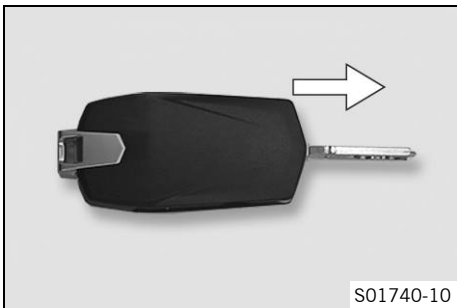

- Fold out the key bit of the Race-on key.
- Push the lower half of the Race-on key in the direction of the arrow and take off.

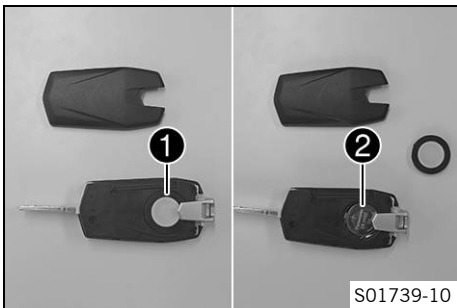

- Remove battery cover ①.
- Remove battery ②.
- Insert the new battery with the marking facing upward.

Battery for Race-on key (CR 2032) (📖 p. 329)

- Mount battery cover ①.

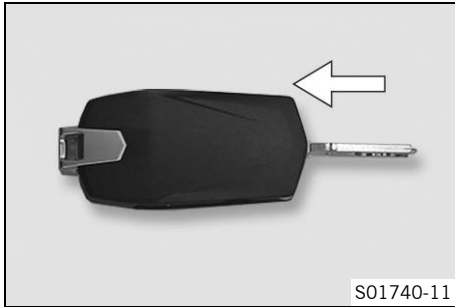

- Fit lower half of the Race-on key and snap into place in the direction of the arrow.



16.7 Changing the main fuse





Warning

Fire hazard Incorrect fuses overload the electrical system.

- Only use fuses with the required ampere value.
- Do not bypass or repair fuses.

Preparatory work

- Switch off ignition - to do this briefly press the Race-on button  (maximum of 1 second) with the ignition switched on.
- Remove the seat. ( p. 195)

16 ELECTRICAL SYSTEM

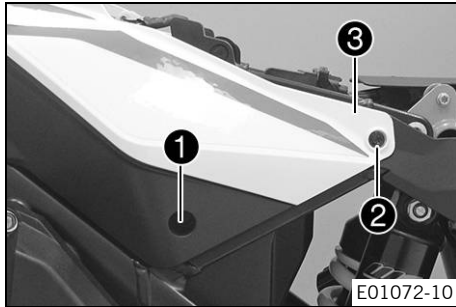

Main work

- Remove screw ❶ and screw ❷.
- Carefully raise rear fairing ❸ slightly.

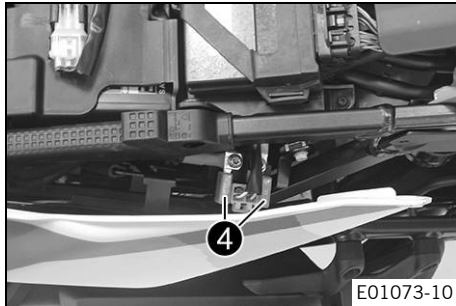

- Take off protection caps ❹.

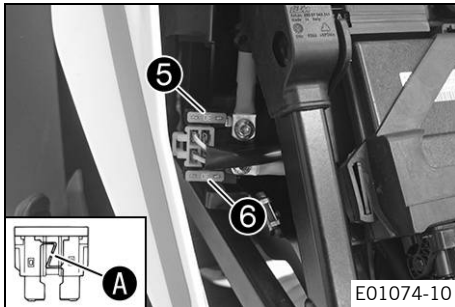

- Remove faulty main fuse **5**.



Info

You can recognize a faulty fuse by a burned-out fuse wire **A**.

A spare fuse **6** is located in the starter relay.

The main fuse protects all power consumers of the vehicle.

- Install a new main fuse.

Fuse (58011109130) (📖 p. 329)

- Check that the electrical system is functioning properly.
- Mount the protection caps.



Tip

Insert a new spare fuse into the starter relay to have it available when needed.

16 ELECTRICAL SYSTEM

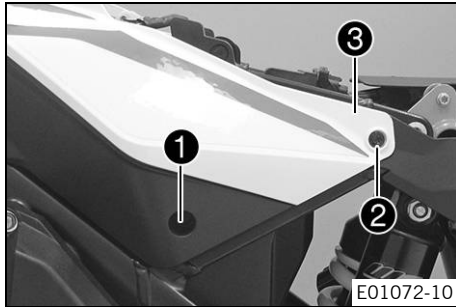

- Position rear fairing ③.
- Mount and tighten screw ②.

Guideline

Screw, cover part	M5x17	3.5 Nm (2.58 lbf ft)
-------------------	-------	-------------------------

- Mount and tighten screw ①.

Guideline

Screw, cover part	M5x12	3.5 Nm (2.58 lbf ft)
-------------------	-------	-------------------------

Finishing work

- Mount the seat. (📖 p. 195)
- Set the time and date.

16.8 Changing the fuses in the fuse box



Warning



Fire hazard Incorrect fuses overload the electrical system.

- Only use fuses with the required ampere value.
- Do not bypass or repair fuses.

**Info**

The fuse box containing the fuses of individual power consumers is located under the seat.

Preparatory work

- Switch off ignition - to do this briefly press the Race-on button  (maximum of 1 second) with the ignition switched on.
- Remove the seat. ( p. 195)

Main work

- Open fuse box cover **1**.

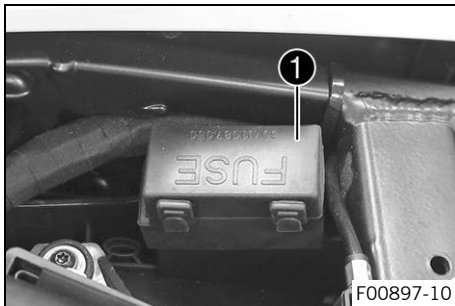

16 ELECTRICAL SYSTEM

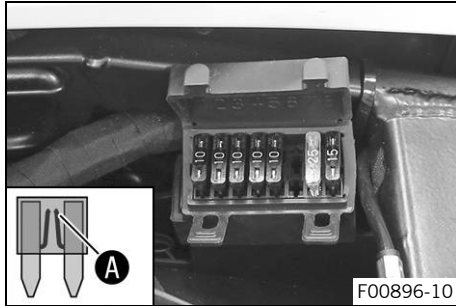

- Check the fuses.



Info

You can recognize a faulty fuse by a burned-out fuse wire **A**.

- Remove the faulty fuse.

Guideline

Fuse 1 - 10 A - power supply for control units and components
Fuse 2 - 10 A - permanent positive for auxiliary equipment (ACC1), accessories connected with ignition for auxiliary equipment (ACC2)
Fuse 3 - 10 A - headlight control unit
Fuse 4 - 10 A - headlight control unit
Fuse 5 - 10 A - engine electronics control unit
Fuse 6 - not assigned
Fuse 7 - 25 A - ABS return pump
Fuse 8 - 15 A - ABS hydraulic unit

- Use spare fuses with the correct rating only.

Fuse (58011109110) (📖 p. 329)
Fuse (58011109115) (📖 p. 329)
Fuse (58011109125) (📖 p. 329)

**Tip**

Insert a spare fuse so that it is available if needed.

- Check that the power consumer is functioning properly.
- Close the fuse box cover.

Finishing work

- Mount the seat. (📖 p. 195)
- 

16.9 Changing the turn signal bulb

Note

Damage to reflector Grease on the reflector reduces the brightness.

Grease on the bulb will evaporate due to the heat and be deposited on the reflector.

- Clean and degrease the bulbs before mounting.
 - Do not touch the bulbs with your bare hands.
-

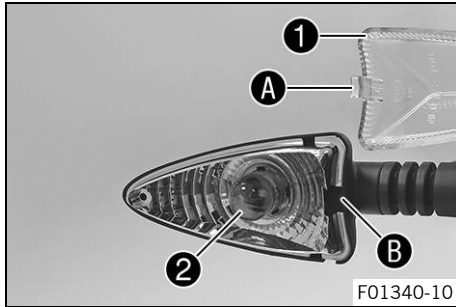

- Remove the screw on the front of the turn signal housing.
- Carefully remove diffuser ①.
- Press bulb ② carefully into the socket, turn it counterclockwise by about 30°, and pull it out of the socket.



Info

Do not touch the reflector with your fingers, and keep it free from grease.

- Press the new bulb carefully into the socket and turn it clockwise until it stops.

Turn signal (RY10W / socket BAU15s) (📖 p. 329)

- Check the turn signal to make sure it is functioning properly.
- Position the diffuser.



Info

Hook in projection ① at recess ②.

- Insert the screw and first turn it counterclockwise until it engages in the thread. Tighten the screw slightly.

16.10 Checking the headlight setting

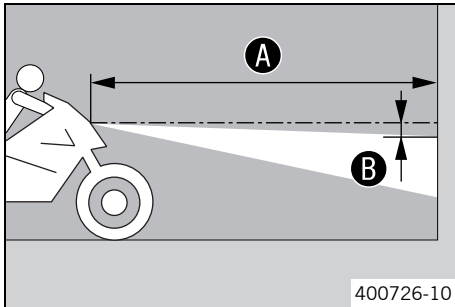

- Park the vehicle on a horizontal surface in front of a light-colored wall and make a mark at the height of the center of the low beam headlight.
- Make another mark at a distance **B** under the first marking.

Guideline

Distance B	5 cm (2 in)
-------------------	-------------

- Position the vehicle perpendicular to the wall at a distance **A** from the wall and switch on the low beam.

Guideline

Distance A	5 m (16 ft)
-------------------	-------------

- The rider, with luggage and passenger if applicable, now mounts the motorcycle.
- Check the headlight setting.

The light-dark boundary must lie exactly on the lower mark when the motorcycle is ready to operate with the rider mounted along with any luggage and a passenger if applicable.

- » If the boundary between light and dark does not meet specifications:
 - Adjust the headlight range. (📖 p. 286)



16.11 Adjusting the headlight range

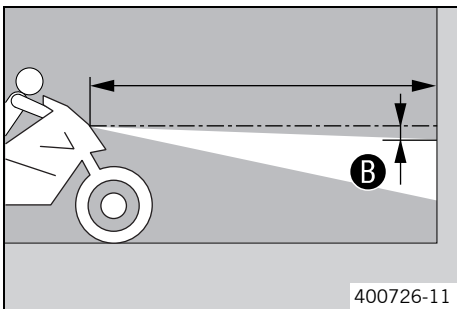

Preparatory work

- Check the headlight setting. (📖 p. 285)

Main work

- Turn adjusting wheel **1** to adjust the headlight range.

Info

Turn counterclockwise to increase the headlight range; turn clockwise to reduce the headlight range. If you have a payload, you may have to correct the headlight range.

- Set the headlight to marking **B**.

Guideline

The light-dark boundary must lie exactly on lower mark **B** when the motorcycle is ready to operate with the rider mounted along with any luggage and a passenger if applicable.

16.12 Diagnostics connector

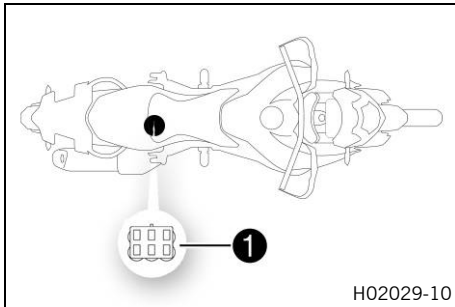

Diagnostics connector **1** is located under the front rider's seat.

16.13 Front ACC1 and ACC2

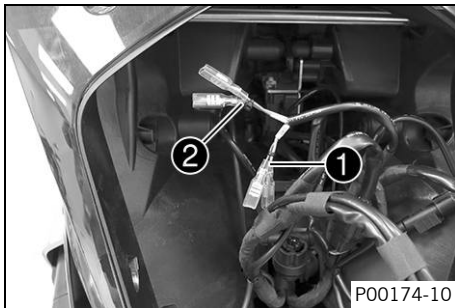

Installation location

- The front power supplies ACC1 **1** and ACC2 **2** are located behind the headlight.

i Info

The power supplies are protected by a fuse, however this fuse also protects other power consumers. The maximum continuous load is therefore significantly lower than the value of the fuse. Do not use a stronger fuse.

16.14 ACC1 and ACC2 rear

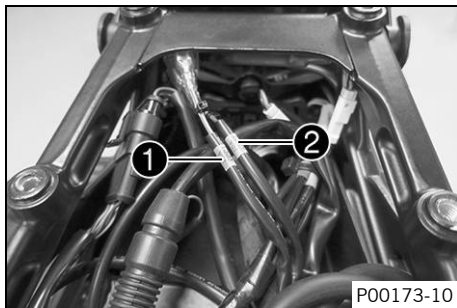

Installation location

- The rear power supplies ACC1 ① and ACC2 ② are located under the luggage rack plate.

i Info

The power supplies are protected by a fuse, however this fuse also protects other power consumers. The maximum continuous load is therefore significantly lower than the value of the fuse. Do not use a stronger fuse.

17.1 Checking the coolant level in the compensating tank



Warning

Danger of scalding During motorcycle operation, the coolant gets very hot and is under pressure.

- Do not open the radiator, the radiator hoses or other cooling system components if the engine or the cooling system are at operating temperature.
- Allow the cooling system and the engine to cool down before you open the radiator, the radiator hoses or other components of the cooling system.
- In the event of scalding, rinse the area affected immediately with lukewarm water.



Warning

Danger of poisoning Coolant is toxic and a health hazard.

- Keep coolant out of the reach of children.
- Do not allow coolant to come into contact with the skin, the eyes and clothing.
- Consult a doctor immediately if coolant is swallowed.
- Rinse the affected area immediately with plenty of water in the event of contact with the skin.
- Rinse eyes thoroughly with water and consult a doctor immediately if coolant gets into the eyes.
- Change clothing if coolant spills onto your clothing.

Condition

The engine is cold.

The radiator is completely full.

17 COOLING SYSTEM

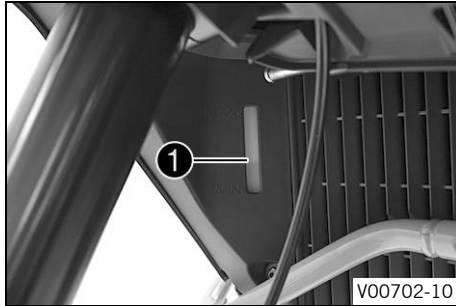

- Park the motorcycle on a horizontal surface.
- Check the coolant level in the compensating tank ①.

The coolant level must be between **MIN** and **MAX**.

- » If there is no coolant in the compensating tank:
 - Check the cooling system for leaks. 🛠️



Info

Do not start up the motorcycle!

- Add coolant/bleed the cooling system. 🛠️
- » If the coolant in the compensating tank is not at the required level, but the tank is not empty:
 - Correct the coolant level in the compensating tank. (📖 p. 291)

17.2 Correcting the coolant level in the compensating tank



Warning

Danger of scalding During motorcycle operation, the coolant gets very hot and is under pressure.

- Do not open the radiator, the radiator hoses or other cooling system components if the engine or the cooling system are at operating temperature.
- Allow the cooling system and the engine to cool down before you open the radiator, the radiator hoses or other components of the cooling system.
- In the event of scalding, rinse the area affected immediately with lukewarm water.



Warning

Danger of poisoning Coolant is toxic and a health hazard.

- Keep coolant out of the reach of children.
- Do not allow coolant to come into contact with the skin, the eyes and clothing.
- Consult a doctor immediately if coolant is swallowed.
- Rinse the affected area immediately with plenty of water in the event of contact with the skin.
- Rinse eyes thoroughly with water and consult a doctor immediately if coolant gets into the eyes.
- Change clothing if coolant spills onto your clothing.

Condition

The engine is cold.

The radiator is completely full.

Preparatory work

- Check the coolant level in the compensating tank. (📖 p. 289)
- Remove the front side cover. (📖 p. 209)



Info

Only disassemble the right-hand side.

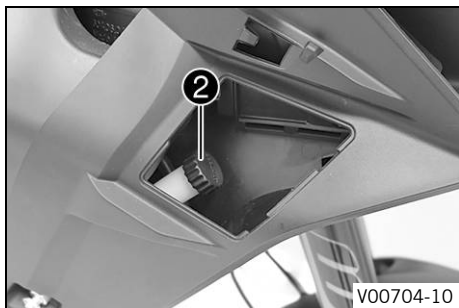

Main work

- Remove cover **1**.

- Remove cover **2** of the compensating tank.



- Add coolant until the coolant reaches the specified level.

Guideline

The coolant level must be between **MIN** and **MAX**.

Coolant (📖 p. 344)

- Mount cover ❷ of the compensating tank.
- Mount cover ❶.

Finishing work

- Install the front side cover. (📖 p. 210)



18.1 Ride Mode



Possible states

- **SPORT** – Homologated performance with very direct response; the traction control allows greater slip on the rear wheel.
- **STREET** – Homologated performance with balanced response; the traction control allows normal slip on the rear wheel.
- **RAIN** – Reduced homologated performance for better rideability; the traction control allows normal slip on the rear wheel.
- **OFFROAD** – Reduced homologated performance for better rideability; the traction control allows high slip on the rear wheel

Various vehicle tunings can be selected in the **Ride Mode** menu.

SPORT, **STREET**, **RAIN** and **OFFROAD** are available.

The drive mode selected last is displayed in the combination instrument.

The drive mode can also be changed while riding with a closed throttle grip and deactivated speed sensor.

18.2 Motorcycle traction control (MTC)

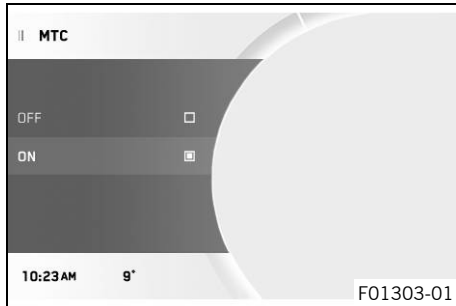



The motorcycle traction control (MTC) lowers the engine torque in case of loss of traction in the rear wheel. Depending on the motorcycle traction control setting, a slight slip on the rear wheel may be desirable. Example: offroad.

i Info

When motorcycle traction control is switched off, the rear wheel may spin during strong acceleration and on surfaces with low grip, resulting in a risk of crashing. After the ignition is switched back on, motorcycle traction control is enabled again.

The motorcycle traction control is controlled via the **Motorcycle** menu on the combination instrument. The motorcycle traction control can be switched off in the **MTC** menu.

i Info

When the motorcycle traction control is active, the TC indicator lamp  flashes. When motorcycle traction control is switched off, the TC indicator lamp  lights up.

19.1 Checking the engine oil level

i Info

Oil consumption depends on the riding style and the operating conditions.

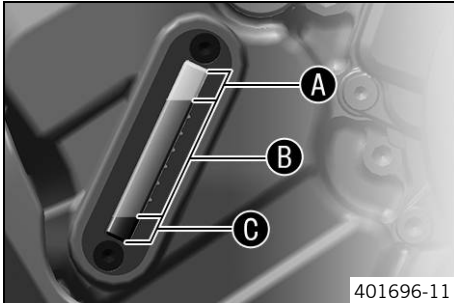

Condition

The engine is at operating temperature.

Preparatory work

- Stand the motorcycle upright on a horizontal surface.

Main work



- Check the engine oil level in the engine oil level viewer.

i Info

After switching off the engine, wait one minute before checking the level.

The engine oil level should be in the upper part of the range **B** of the engine oil level viewer.

- » When the engine oil level is in area **A** of the engine oil level viewer:
 - Do not add engine oil.
- » When the engine oil level is in area **B** of the engine oil level viewer:
 - Engine oil can be added.

- » When the engine oil level is in area  of the engine oil level viewer:
 - Add engine oil. ( p. 304)



19.2 Changing the engine oil and oil filter, cleaning the oil screens



Warning

Danger of scalding Engine and gear oil get very hot when the motorcycle is ridden.

- Wear suitable protective clothing and safety gloves.
- In the event of scalding, rinse the area affected immediately with lukewarm water.



Warning

Environmental hazard Hazardous substances cause environmental damage.

- Dispose of oils, grease, filters, fuel, cleaning agents, brake fluid, etc., correctly and in compliance with the applicable regulations.

Preparatory work

- Remove the engine guard. ( p. 226)

19 SERVICE WORK ON THE ENGINE

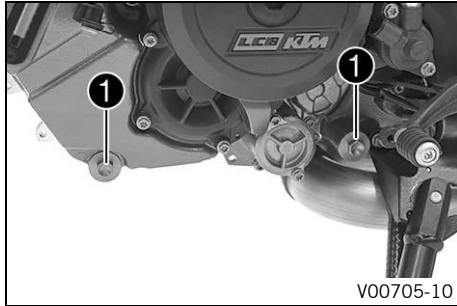

Main work

- Stand the motorcycle on its side stand on a horizontal surface.
- Place a suitable container under the engine.
- Remove oil drain plugs **1** with the magnets, O-rings, and oil screens.

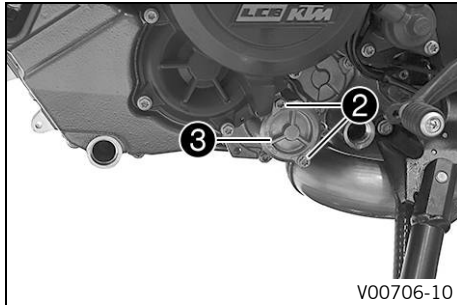

- Remove screws **2**. Remove oil filter cover **3** with the O-ring.

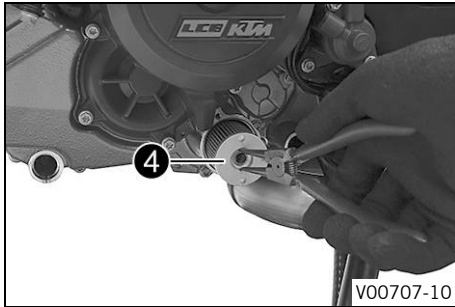

- Pull oil filter ④ out of the oil filter housing.

Lock ring plier (51012011000)

- Completely drain the engine oil.
- Thoroughly clean the parts and sealing surface.

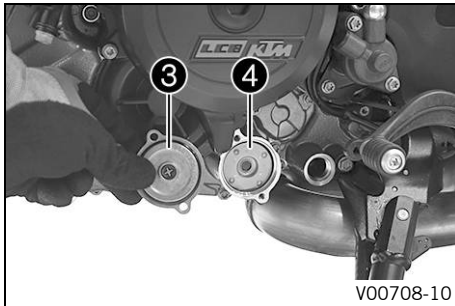

- Insert new oil filter ④.
- Oil the O-ring of the oil filter cover. Mount oil filter cover ③.

19 SERVICE WORK ON THE ENGINE

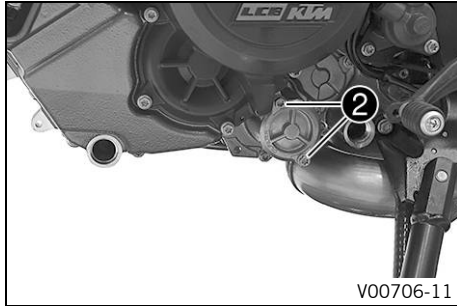

- Mount and tighten screws ②.

Guideline

Remaining engine screws	M5	6 Nm (4.4 lbf ft)
-------------------------	----	-------------------

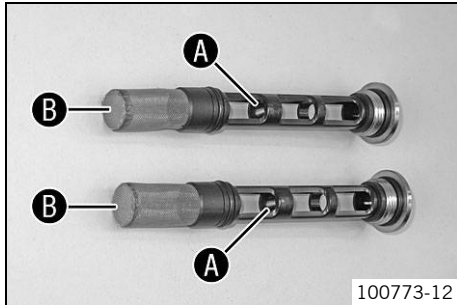

- Thoroughly clean magnets ① and oil screens ② of the oil drain plugs.

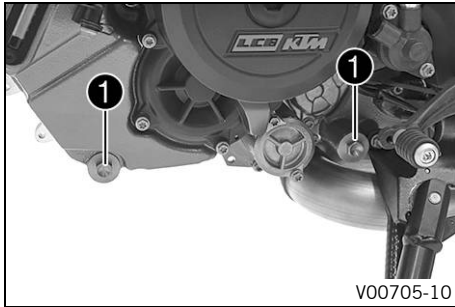

- Mount and tighten oil drain plugs **1** with the magnets, O-rings, and oil screens.

Guideline

Oil drain plug	M20x1.5	20 Nm (14.8 lbf ft)
----------------	---------	---------------------

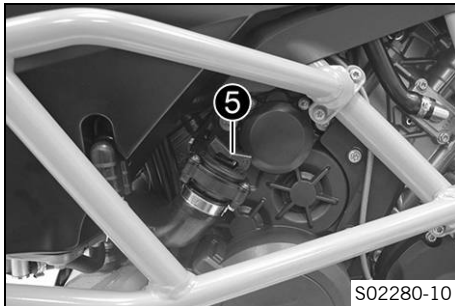

- Have the entire filling quantity available.

Engine oil Outside temperature: ≥ 0 °C (≥ 32 °F)	3.60 l (3.8 qt.)	Engine oil (SAE 10W/50) (📖 p. 345)
Engine oil Outside temperature: < 0 °C (< 32 °F)		Engine oil (SAE 5W/40) (📖 p. 346)

- Add the oil quantity quantity in two separate operations.
- Remove screw plug **5** and fill up with initial partial quantity.

Engine oil (1st partial quantity) approx. Outside temperature: ≥ 0 °C (≥ 32 °F)	3.0 l (3.2 qt.)	Engine oil (SAE 10W/50) (📖 p. 345)
---	-----------------	--

Engine oil (1st partial quantity) approx. Outside temperature: < 0 °C (< 32 °F)	3.0 l (3.2 qt.)	Engine oil (SAE 5W/40) (📖 p. 346)
---	-----------------	-----------------------------------

- Mount screw plug ⑤.



Danger

Danger of poisoning Exhaust gases are toxic and inhaling them may result in unconsciousness and death.

- Always make sure there is sufficient ventilation when running the engine.
 - Use an effective exhaust extraction system when starting or running the engine in an enclosed space.
-
- Start the engine and check that it is oil-tight.
 - Switch off the engine.

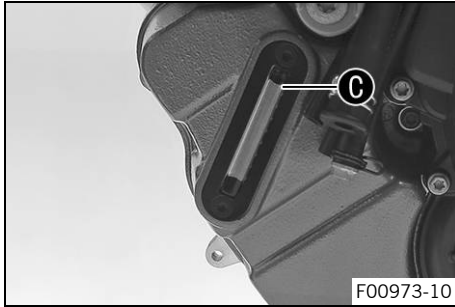

- Remove the screw plug and add the second partial quantity up to the upper marking **C** on the engine oil level viewer.

Engine oil (2nd partial quantity) approx. Outside temperature: $\geq 0\text{ }^{\circ}\text{C}$ ($\geq 32\text{ }^{\circ}\text{F}$)	0.60 l (0.63 qt.)	Engine oil (SAE 10W/50) (p. 345)
Engine oil (2nd partial quantity) approx. Outside temperature: $< 0\text{ }^{\circ}\text{C}$ ($< 32\text{ }^{\circ}\text{F}$)		Engine oil (SAE 5W/40) (p. 346)

- Mount the screw plug.



Danger

Danger of poisoning Exhaust gases are toxic and inhaling them may result in unconsciousness and death.

- Always make sure there is sufficient ventilation when running the engine.
- Use an effective exhaust extraction system when starting or running the engine in an enclosed space.

- Start the engine and check that it is oil-tight.

Finishing work

- Check the engine oil level. (p. 296)

- Install the engine guard. (📖 p. 226)

19.3 Adding engine oil



Info

Too little engine oil or poor-quality engine oil results in premature wear to the engine. The engine may be damaged if the engine oil level is too high.

Condition

The engine is at operating temperature.

Preparatory work

- Stand the motorcycle upright on a horizontal surface.
- Check the engine oil level. (📖 p. 296)

Main work

- Remove screw plug ①.

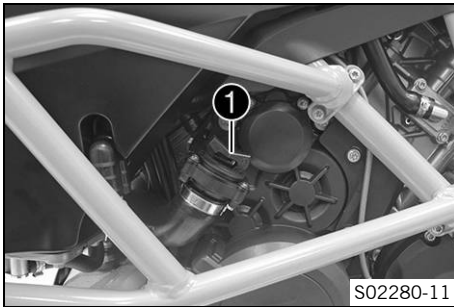

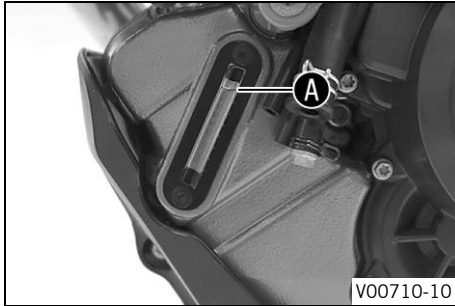

- Add engine oil to the upper marking **A** on the engine oil level viewer.

Condition

Outside temperature: $\geq 0\text{ }^{\circ}\text{C}$ ($\geq 32\text{ }^{\circ}\text{F}$)

Engine oil (SAE 10W/50) (📖 p. 345)

Condition

Outside temperature: $< 0\text{ }^{\circ}\text{C}$ ($< 32\text{ }^{\circ}\text{F}$)

Engine oil (SAE 5W/40) (📖 p. 346)



Info

In order to achieve optimal engine performance, it is not advisable to mix different engine oils. KTM recommends changing the engine oil.

- Mount the screw plug.



Danger

Danger of poisoning Exhaust gases are toxic and inhaling them may result in unconsciousness and death.

- Always make sure there is sufficient ventilation when running the engine.
- Use an effective exhaust extraction system when starting or running the engine in an enclosed space.

- Start the engine and check that it is oil-tight.

19 SERVICE WORK ON THE ENGINE

Finishing work

- Check the engine oil level. (📖 p. 296)



20.1 Cleaning motorcycle

Note

Material damage Components become damaged or destroyed if a pressure cleaner is used incorrectly.

The high pressure forces water into the electrical components, connectors, throttle cables, and bearings, etc. Pressure which is too high causes malfunctions and destroys components.

- Do not direct the water jet directly on to electrical components, connectors, throttle cables or bearings.
- Maintain a minimum distance between the nozzle of the pressure cleaner and the component.

Minimum clearance 60 cm (23.6 in)



Warning

Environmental hazard Hazardous substances cause environmental damage.

- Dispose of oils, grease, filters, fuel, cleaning agents, brake fluid, etc., correctly and in compliance with the applicable regulations.
-



Info

If you clean the motorcycle regularly, its value and appearance will be maintained over a long period. Avoid direct sunshine on the motorcycle during cleaning.

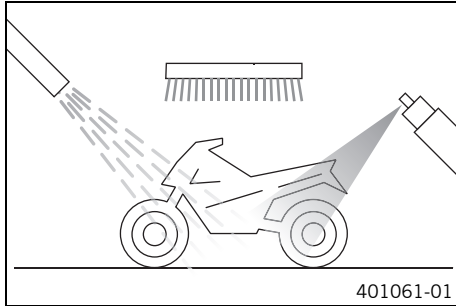

- Close off the exhaust system to keep water from entering.
- First remove coarse dirt particles with a gentle spray of water.
- Spray very dirty areas with a normal motorcycle cleaner and then clean with a brush.

Motorcycle cleaner (📖 p. 349)



Info

Use warm water containing normal motorcycle cleaner and a soft sponge.
Never apply motorcycle cleaner to a dry vehicle; always rinse the vehicle with water first.
If the vehicle was operated in road salt, clean it with cold water. Warm water would enhance the corrosive effects of salt.

- After rinsing the motorcycle with a gentle spray of water, allow it to dry thoroughly.
- Remove the closure of the exhaust system.



Warning

Danger of accidents Moisture and dirt impair the brake system.

- Brake carefully several times to dry out and remove dirt from the brake linings and the brake discs.

- After cleaning, ride the vehicle a short distance until the engine warms up.



Info

The heat produced causes water at inaccessible locations in the engine and on the brake system to evaporate.

- Push back the protection caps of the handlebar controls to allow any water that has penetrated to evaporate.
- After the motorcycle has cooled off, lubricate all moving parts and bearings.
- Clean the chain. (📖 p. 196)
- Treat bare metal parts (except for brake discs and exhaust system) with corrosion inhibitor.

Preserving materials for paints, metal and rubber
(📖 p. 349)

- Treat the painted parts with a mild paint polish.

Perfect Finish and high gloss polish for paints (📖 p. 349)



Info

Do not polish plastic parts that are matte when the vehicle is delivered as this would seriously impair the material quality.

- Treat the plastic parts and powder-coated parts with a mild cleaning and care product.

Special cleaner for glossy and matte paint finishes, metal and plastic surfaces (📖 p. 349)

- Oil the ignition/steering lock, tank lock, and seat lock.

Universal oil spray (📖 p. 349)

20.2 Checks and maintenance steps for winter operation

i Info

If you use the motorcycle in winter, you must expect salt on the roads. You should therefore take precautions against aggressive road salt.

If the vehicle was operated in road salt, clean it with cold water after riding. Warm water would enhance the corrosive effects of salt.

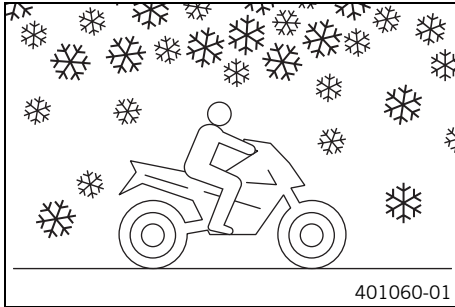

- Clean the motorcycle. (📖 p. 307)
- Clean the brakes.



Info

After **EVERY** trip on salted roads, thoroughly wash the brake calipers and brake linings with cold water and dry carefully. This should be done after the parts are cooled down and while they are installed.
After riding on salted roads, thoroughly wash the motorcycle with cold water and dry it well.

- Treat the engine, the swingarm, and all other bare or galvanized parts (except brake discs) with a wax-based corrosion inhibitor.



Info

Corrosion inhibitor must not come into contact with the brake discs. This would severely lower the braking effect.

- Clean the chain. (📖 p. 196)



21.1 Storage



Info

If you plan to garage the motorcycle for a longer period, perform the following steps or have them performed.

Before storing the motorcycle, check all parts for function and wear. If service, repairs or replacements are necessary, you should do this during the storage period (less workshop overload). In this way, you can avoid long workshop waiting times at the start of the new season.

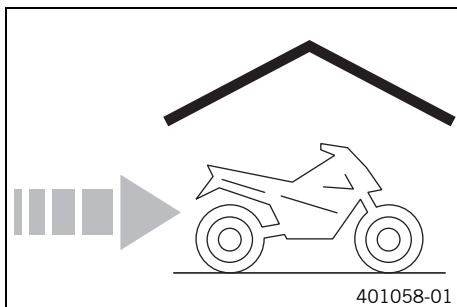

- When refueling for the last time before taking the motorcycle out of service, add fuel additive.

Fuel additive (📖 p. 348)

- Refuel. (📖 p. 176)
- Clean the motorcycle. (📖 p. 307)
- Change the engine oil and oil filter and clean the oil screens. 🛠️ (📖 p. 297)
- Check the coolant fill level and antifreeze. 🛠️
- Check the tire air pressure. (📖 p. 261)
- Remove the battery. 🛠️ (📖 p. 266)

Guideline

Storage temperature of battery without direct sunshine	0 ... 35 °C (32 ... 95 °F)
--	----------------------------

- Recharge the battery. 🛠️ (📖 p. 271)

- Store the vehicle in a dry location that is not subject to large fluctuations in temperature.
- Raise the vehicle with the center stand. (📖 p. 193)
- Cover the vehicle with a tarp or similar cover that is permeable to air.

**Info**

Do not use non-porous materials since they prevent humidity from escaping, thus causing corrosion. Avoid running the engine for a short time only. Since the engine cannot warm up properly, the water vapor produced during combustion condenses and causes valves and the exhaust system to rust.



21.2 Preparing for use after storage

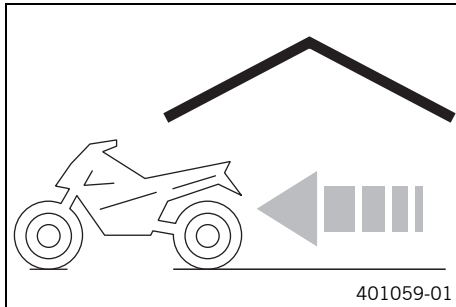

- Remove the vehicle from the center stand. (📖 p. 194)
- Install the battery. 🔧 (📖 p. 268)



Info

If the battery was removed, the time and date must be set.

- Perform checks and maintenance measures when preparing for use. (📖 p. 156)
- Take a test ride.



The Race-on indicator lamp ❶ can indicate errors by flashing. The flashing occurs for up to five seconds after actuating the Race-on tip switch.

i Info

Blink codes referring to **KTM RACE ON** are only displayed once and not repeated.

Faults	Possible cause	Action
No response if the Race-on tip switch is pressed	Race-on tip switch faulty	<ul style="list-style-type: none"> – Check Race-on tip switch for damage. – Check cable and plug of Race-on tip switch for damage.

Faults	Possible cause	Action
Race-on indicator lamp flashes twice	No response signal from the Race-on key	<ul style="list-style-type: none"> – Ensure that the Race-on key is in range. – Remove other electronic devices from the vicinity of the Race-on antenna. – Check battery compartment in the Race-on key for correct locking. – Check battery holder of the Race-on key for corrosion. – Change the Race-on key battery. (📖 p. 276) – Use black ignition key.
Race-on indicator lamp flashes three times	The battery is discharged	<ul style="list-style-type: none"> – Recharge the battery. 🗑️ (📖 p. 271) – Check the open-circuit current. 🗑️
Race-on indicator lamp flashes four times	Steering lock bolt locked or tense	<ul style="list-style-type: none"> – Move handlebar slightly.
Race-on indicator lamp flashes five times	Race-on antenna faulty	<ul style="list-style-type: none"> – Check Race-on antenna for damage.
The combination instrument shows nothing on the display	Fuse 1 blown	<ul style="list-style-type: none"> – Change the fuses in the fuse box. (📖 p. 280)
	Main fuse burned out	<ul style="list-style-type: none"> – Change the main fuse. (📖 p. 277)
	The battery is discharged	<ul style="list-style-type: none"> – Recharge the battery. 🗑️ (📖 p. 271) – Check the open-circuit current. 🗑️

Faults	Possible cause	Action
The engine does not turn if the emergency OFF switch/electric starter button is pressed into the lower position	Operating error	– Carry out the start procedure. (📖 p. 157)
	The battery is discharged	– Recharge the battery. 🛡️ (📖 p. 271) – Check the open-circuit current. 🛡️
	Safety start system is faulty	– Read out the fault memory using the KTM diagnostics tool. 🛡️
	Electronic fault	– Read out the fault memory using the KTM diagnostics tool. 🛡️
Engine turns only if the clutch lever is drawn	The vehicle is in gear	– Shift the transmission to idle 📌.
	Safety start system is faulty	– Read out the fault memory using the KTM diagnostics tool. 🛡️
Engine turns although a gear is engaged	Safety start system is faulty	– Read out the fault memory using the KTM diagnostics tool. 🛡️
Engine turns but does not start	The plug-in connection of the fuel hose connection is not connected	– Connect the plug-in connection of the fuel line.
	Fault in fuel injection system	– Read out the fault memory using the KTM diagnostics tool. 🛡️
	Fuel quality is insufficient	– Add suitable fuel.
Engine dies during the trip	Lack of fuel	– Refuel. (📖 p. 176)
	Fault in fuel injection system	– Read out the fault memory using the KTM diagnostics tool. 🛡️

22 TROUBLESHOOTING

Faults	Possible cause	Action
Malfunction indicator lamp lights up	Fault in fuel injection system	– Read out the fault memory using the KTM diagnostics tool. 🛠️
The ABS indicator lamp lights up	ABS fuse is blown	– Change the fuses in the fuse box. (📖 p. 280)
	Wheel speeds of front and rear wheels differ greatly	– Stop, switch off the ignition, start again.
	Malfunction in ABS	– Read out the fault memory using the KTM diagnostics tool. 🛠️
High oil consumption	Engine oil level too high	– Check the engine oil level. (📖 p. 296)
	Engine oil too thin (low viscosity)	– Change the engine oil and oil filter and clean the oil screens. 🛠️ (📖 p. 297)
The battery is discharged	A power consumer is connected to the socket/ACC1.	– Disconnect the power consumer from the socket/ACC1. – Recharge the battery. 🛠️ (📖 p. 271)
	The hazard warning flasher is switched on	– Switch off the hazard warning flasher. – Recharge the battery. 🛠️ (📖 p. 271)
	Battery is not charged by alternator	– Check the charging voltage. 🛠️
	Ignition was not switched off when vehicle was parked	– Recharge the battery. 🛠️ (📖 p. 271)

23.1 Engine

Design	2-cylinder 4-stroke Otto engine, 75° V arrangement, water-cooled
Displacement	1,301 cm ³ (79.39 cu in)
Stroke	71 mm (2.8 in)
Bore	108 mm (4.25 in)
Compression ratio	13.1:1
Idle speed	1,280 ... 1,480 rpm
Control	DOHC, 4 valves per cylinder, chain-driven
Valve - valve plate diameter	
Intake	42 mm (1.65 in)
Exhaust	34 mm (1.34 in)
Valve clearance	
Exhaust at: 20 °C (68 °F)	0.25 ... 0.30 mm (0.0098 ... 0.0118 in)
Intake at: 20 °C (68 °F)	0.10 ... 0.15 mm (0.0039 ... 0.0059 in)
Crankshaft bearing	Sleeve bearing
Conrod bearing	Sleeve bearing
Piston	Forged light alloy
Piston ring	1 upper compression (rectangular) ring, 1 lower compression ring, 1 oil scraper ring

23 TECHNICAL DATA

Engine lubrication	Pressure circulation lubrication with three rotary pumps
Primary transmission	40:76
Clutch	Antihopping clutch in oil bath/hydraulically operated
Transmission	6-speed claw gears
Transmission ratio	
1st gear	12:35
2nd gear	15:32
3rd gear	18:30
4th gear	20:27
5th gear	24:27
6th gear	35:32
Mixture preparation	Electronically controlled fuel injection
Ignition system	Contactless controlled fully electronic ignition with digital ignition adjustment
Alternator	12 V, 450 W
Spark plug	
Inside spark plug	NGK LKAR9BI-10
Outside spark plug	NGK LMAR7DI-10
Electrode gap, spark plug	1.0 mm (0.039 in)
Cooling	Water cooling, permanent circulation of coolant by water pump

Cold start device	Electric starter
-------------------	------------------

23.2 Engine tightening torques

Screw, damping plate	EJOT Altracs® M6x14	10 Nm (7.4 lbf ft) Loctite®243™
Screw, retaining bracket, valve cover, rear	EJOT Altracs® M6x10	10 Nm (7.4 lbf ft)
Hose clip, intake flange	M4	1.5 Nm (1.11 lbf ft)
Oil nozzle	M5	2 Nm (1.5 lbf ft) Loctite®243™
Remaining engine screws	M5	6 Nm (4.4 lbf ft)
Screw, bearing retainer	M5	6 Nm (4.4 lbf ft) Loctite®243™
Screw, bearing shells retaining bracket	M5	6 Nm (4.4 lbf ft) Loctite®243™
Screw, engine oil level viewer	M5	4 Nm (3 lbf ft)
Screw, gear sensor	M5	6 Nm (4.4 lbf ft) Loctite®243™
Screw, pulse generator	M5	6 Nm (4.4 lbf ft) Loctite®243™
Screw, resonator	M5	8 Nm (5.9 lbf ft) Loctite®243™

23 TECHNICAL DATA

Swing angle sensor screw	M5	5 Nm (3.7 lbf ft)	Loctite®243™
Bleeder screw, water pump cover	M6	10 Nm (7.4 lbf ft)	
Bracket, fuel tank connecting hose	M6	10 Nm (7.4 lbf ft)	Loctite®243™
Coolant connection screw on the cylinder head	M6	8 Nm (5.9 lbf ft)	Loctite®243™
Freewheel ring bolt	M6 – 10.9	15 Nm (11.1 lbf ft)	Loctite® 648™
Nut, cylinder head	M6	9 Nm (6.6 lbf ft)	
Remaining engine screws	M6	10 Nm (7.4 lbf ft)	
Screw, camshaft bearing support	M6 – 10.9	10 Nm (7.4 lbf ft)	
Screw, clutch cover	M6	10 Nm (7.4 lbf ft)	
Screw, clutch spring	M6	12 Nm (8.9 lbf ft)	
Screw, engine case	M6x60	10 Nm (7.4 lbf ft)	
Screw, engine case	M6x80	10 Nm (7.4 lbf ft)	
Screw, engine case	M6x90	10 Nm (7.4 lbf ft)	
Screw, freewheel holder	M6	10 Nm (7.4 lbf ft)	Loctite®243™
Screw, locking lever	M6	10 Nm (7.4 lbf ft)	Loctite®243™
Screw, oil pump cover	M6	10 Nm (7.4 lbf ft)	Loctite®243™

Screw, shift drum locating	M6 – 12.9	18 Nm (13.3 lbf ft) Loctite®243™
Screw, shift lever	M6	15 Nm (11.1 lbf ft) Loctite®243™
Screw, starter motor	M6	10 Nm (7.4 lbf ft)
Screw, stator	M6	10 Nm (7.4 lbf ft) Loctite®243™
Screw, valve cover	M6	10 Nm (7.4 lbf ft)
Screw, water pump cover	M6	10 Nm (7.4 lbf ft)
Screw, water pump wheel	M6	10 Nm (7.4 lbf ft) Loctite®243™
Stud, chain shaft	M6	8 Nm (5.9 lbf ft)
Vacuum connection	M6	5 Nm (3.7 lbf ft) Loctite®243™
Nozzle 100	M6x0.75	4 Nm (3 lbf ft) Loctite®243™
Plug, crankshaft retainer	M8	15 Nm (11.1 lbf ft)
Screw, camshaft bearing support	M8 – 10.9	Step 1 10 Nm (7.4 lbf ft) Step 2 18 Nm (13.3 lbf ft)

23 TECHNICAL DATA

Screw, camshaft bearing support	M8 – 10.9	Step 1 8.5 Nm (6.27 lbf ft) Step 2 14.5 Nm (10.7 lbf ft) Only applies when using: Hexagon socket bit (61229025000)
Screw, engine case	Expansion screw M8	18 Nm (13.3 lbf ft)
Screw, heat exchanger	M8	15 Nm (11.1 lbf ft)
Screw, timing chain guide rail	M8	15 Nm (11.1 lbf ft) Loctite®243™
Screw, timing chain tensioning rail	M8	15 Nm (11.1 lbf ft) Loctite®243™
Stud, exhaust flange	M8	10 Nm (7.4 lbf ft)
Screw, engine bearer	M10	45 Nm (33.2 lbf ft)
Oil pressure sensor	M10x1	10 Nm (7.4 lbf ft)
Plug, cam lever axis	M10x1	15 Nm (11.1 lbf ft)
Plug, clutch lubrication	M10x1	10 Nm (7.4 lbf ft)
Screw plug, spreading transmission lock	M10x1	12 Nm (8.9 lbf ft)

Screw, conrod bearing	M10x1	Step 1 25 Nm (18.4 lbf ft) Step 2 30 Nm (22.1 lbf ft) Step 3 90°
Screw, timing chain tensioner release	M10x1	10 Nm (7.4 lbf ft)
Spark plug	M10x1	11 Nm (8.1 lbf ft)
Cylinder head screw	M11x1.5	Tightening sequence: Using a crisscross pattern Step 1 15 Nm (11.1 lbf ft) Step 2 30 Nm (22.1 lbf ft) Step 3 90° Step 4 90° Lubricated with engine oil
Coolant temperature sensor	M12x1.5	12 Nm (8.9 lbf ft)
Screw, rotor	Expansion screw M12x1.5	115 Nm (84.8 lbf ft)
Spark plug	M12x1.5	18 Nm (13.3 lbf ft)
Nut of engine sprocket	M20x1.5	100 Nm (73.8 lbf ft) Loctite®243™

23 TECHNICAL DATA

Oil drain plug	M20x1.5	20 Nm (14.8 lbf ft)
Nut, inner clutch hub	M22x1.5	120 Nm (88.5 lbf ft) Loctite®243™
Plug, timing-chain tensioner	M24x1.5	25 Nm (18.4 lbf ft)
Screw in alternator cover	M24x1.5	8 Nm (5.9 lbf ft)
Nut, primary gear	M33LHx1.5	130 Nm (95.9 lbf ft) Loctite®243™

23.3 Capacities

23.3.1 Engine oil

Engine oil Outside temperature: $\geq 0\text{ }^{\circ}\text{C}$ ($\geq 32\text{ }^{\circ}\text{F}$)	3.60 l (3.8 qt.)	Engine oil (SAE 10W/50) (📖 p. 345)
Engine oil Outside temperature: $< 0\text{ }^{\circ}\text{C}$ ($< 32\text{ }^{\circ}\text{F}$)		Engine oil (SAE 5W/40) (📖 p. 346)

23.3.2 Coolant

Coolant	2.40 l (2.54 qt.)	Coolant (📖 p. 344)
---------	-------------------	--------------------

23.3.3 Fuel

Total fuel tank capacity, approx.	23 l (6.1 US gal)	Super unleaded (ROZ 95/RON 95/PON 91) (📖 p. 347)
Fuel reserve, approx.	3.5 l (3.7 qt.)	

23.4 Chassis

Frame	Lattice frame made of chrome molybdenum steel tubing, powder-coated	
Fork	WP Performance Systems 4860 ROTA SPLIT	
Shock absorber	WP Performance Systems 4618 DCC PA	
Suspension travel		
front	220 mm (8.66 in)	
rear	220 mm (8.66 in)	
Brake system		
front	Double disc brake with radially mounted, four-pot brake calipers, floating brake discs	
rear	Single disc brake with dual-piston brake caliper, floating brake disc	
Brake discs - diameter		
front	320 mm (12.6 in)	
rear	267 mm (10.51 in)	

23 TECHNICAL DATA

Brake discs - wear limit	
front	4 mm (0.16 in)
rear	4.5 mm (0.177 in)
Tire air pressure, solo/with passenger/full payload	
front: with cold tires	2.6 bar (38 psi)
rear: with cold tires	2.9 bar (42 psi)
Secondary drive ratio	17:42
Chain	5/8 x 5/16" (525) X-ring
Steering head angle	64°
Wheelbase	1,580 ± 15 mm (62.2 ± 0.59 in)
Seat height, unloaded	890 mm (35.04 in)
Ground clearance, unloaded	250 mm (9.84 in)
Weight without fuel, approx.	229.3 kg (505.5 lb.)
Maximum permissible front axle load	165 kg (364 lb.)
Maximum permissible rear axle load	285 kg (628 lb.)
Maximum permissible total weight	450 kg (992 lb.)

23.5 Electrical system

Battery	YTZ14S	Battery voltage: 12 V Nominal capacity: 11.2 Ah maintenance-free
---------	--------	--

Battery for Race-on key	CR 2032	3 V
Fuse	58011109110	10 A
Fuse	58011109115	15 A
Fuse	58011109125	25 A
Fuse	58011109130	30 A
Low beam	LED	
High beam	LED	
Position light	LED	
Cornering light	LED	
Instrument lights and indicator lamps	LED	
Turn signal	RY10W / socket BAU15s	12 V 10 W
Tail light	LED	
Brake light	LED	
License plate lamp	LED	

23.6 Tires

Front tire	Rear tire
90/90 - 21 M/C 54T M+S TL Continental TKC 80 Twinduro	150/70 B 18 M/C 70Q M+S TL Continental TKC 80 Twinduro
The tires specified represent one of the possible series production tires. Additional information is available in the Service section under: http://www.ktm.com	

23.7 Fork

Fork article number	14.18.8Q.25
Fork	WP Performance Systems 4860 ROTA SPLIT
Compression damping	
Comfort	17 clicks
Standard	12 clicks
Sport	7 clicks
Full payload	7 clicks
Rebound damping	
Comfort	17 clicks
Standard	12 clicks
Sport	7 clicks
Full payload	7 clicks

Spring preload - Preload Adjuster		
Comfort	2 turns	
Standard	5 turns	
Sport	5 turns	
Full payload	8 turns	
Spring length with preload spacer(s)	577 mm (22.72 in)	
Spring rate		
Soft	5.9 N/mm (33.7 lb/in)	
Medium (standard)	6.5 N/mm (37.1 lb/in)	
Hard	7.0 N/mm (40 lb/in)	
Fork length	920 mm (36.22 in)	
Air chamber length	85 ± ₀ ³⁵ mm (3.35 ± ₀ ^{1.38} in)	
Fork oil per fork leg	715 ml (24.17 fl. oz.)	Fork oil (SAE 4) (48601166S1) (📖 p. 346)

23.8 Shock absorber

Shock absorber article number	15.18.7Q.25	
Shock absorber	WP Performance Systems 4618 DCC PA	
Compression damping, low-speed		
Comfort	20 clicks	
Standard	15 clicks	

23 TECHNICAL DATA

Sport	10 clicks
Full payload	10 clicks
Compression damping, high-speed	
Comfort	1.5 turns
Standard	1.5 turns
Sport	1 turn
Full payload	1 turn
Rebound damping	
Comfort	20 clicks
Standard	15 clicks
Sport	10 clicks
Full payload	10 clicks
Spring preload	
Comfort	12 turns
Standard	12 turns
Sport	12 turns
Full payload	18 turns
Spring rate	
Soft	170 N/mm (971 lb/in)
Medium (standard)	180 N/mm (1,028 lb/in)
Hard	190 N/mm (1,085 lb/in)

Spring length	205 mm (8.07 in)
Gas pressure	10 bar (145 psi)
Static sag	25 mm (0.98 in)
Riding sag	55 mm (2.17 in)
Fitted length	408 mm (16.06 in)
Shock absorber fluid (📖 p. 346)	SAE 2.5

23.9 Chassis tightening torques

Nut, tire pressure sensor	ISO 10V2	12 Nm (8.9 lbf ft) Loctite®2701™
Screw, combination switch, left		5 Nm (3.7 lbf ft)
Screw, headlight	EJOT ALtracs® 60x20	8 Nm (5.9 lbf ft)
Screw, headlight holder	EJOT ALtracs® 50x12	7 Nm (5.2 lbf ft)
Screw, fixed grip, left	M4	2 Nm (1.5 lbf ft)
Screw, side stand switch	M4	2 Nm (1.5 lbf ft)
Remaining nuts, chassis	M5	5 Nm (3.7 lbf ft)
Remaining screws, chassis	M5	5 Nm (3.7 lbf ft)
Screw for throttle grip	M5	3.5 Nm (2.58 lbf ft)
Screw, brake line holder on frame	M5	2 Nm (1.5 lbf ft)
Screw, brake line holder on swingarm	M5	5 Nm (3.7 lbf ft)

23 TECHNICAL DATA

Screw, cable channel	M5	5 Nm (3.7 lbf ft)
Screw, cable guide, wheel speed sensor, rear	M5	3 Nm (2.2 lbf ft)
Screw, chain sliding guard	M5	5 Nm (3.7 lbf ft)
Screw, combination instrument	M5	4.5 Nm (3.32 lbf ft)
Screw, combination switch, right	M5	5 Nm (3.7 lbf ft)
Screw, cover part	M5x12	3.5 Nm (2.58 lbf ft)
Screw, filler cap	M5	3 Nm (2.2 lbf ft)
Screw, foot brake lever stub	M5	6 Nm (4.4 lbf ft) Loctite®243™
Screw, fuel level sensor	M5	3 Nm (2.2 lbf ft)
Screw, heat guard on main silencer	M5	4 Nm (3 lbf ft)
Screw, wind shield	M5	3.5 Nm (2.58 lbf ft)
Spoke nipple	M5	5 Nm (3.7 lbf ft)
Ground fitting on frame	M6	6 Nm (4.4 lbf ft)
Nut, ABS module fastening	M6	8 Nm (5.9 lbf ft)
Remaining chassis nuts	M6	10 Nm (7.4 lbf ft)
Remaining chassis screws	M6	10 Nm (7.4 lbf ft)
Screw, angle sensor	M6	6 Nm (4.4 lbf ft) Loctite®243™
Screw, battery terminal	M6	4.5 Nm (3.32 lbf ft)
Screw, bushing	M6	4 Nm (3 lbf ft)

Screw, cable channel	M6	5 Nm (3.7 lbf ft)	
Screw, chain guide	M6	5 Nm (3.7 lbf ft)	
Screw, clutch assembly	M6	5 Nm (3.7 lbf ft)	
Screw, cooler retaining bracket	M6	7 Nm (5.2 lbf ft)	
Screw, cover part	M6	6 Nm (4.4 lbf ft)	
Screw, engine guard	M6	10 Nm (7.4 lbf ft)	
Screw, exhaust clamp	M6	8 Nm (5.9 lbf ft)	
Screw, foot brake cylinder	M6	10 Nm (7.4 lbf ft)	Loctite®243™
Screw, front brake disc	M6	14 Nm (10.3 lbf ft)	Loctite®243™
Screw, front wheel speed sensor	M6	10 Nm (7.4 lbf ft)	
Screw, fuel pump	M6	6 Nm (4.4 lbf ft)	
Screw, fuel tank	M6	10 Nm (7.4 lbf ft)	
Screw, fuel tap	M6	6 Nm (4.4 lbf ft)	
Screw, handlebar clamp hand guard	M6	5 Nm (3.7 lbf ft)	
Screw, lower rear part	M6	6 Nm (4.4 lbf ft)	
Screw, magnetic holder on side stand	M6	6 Nm (4.4 lbf ft)	Loctite®243™
Screw, rear brake disc	M6	14 Nm (10.3 lbf ft)	Loctite®243™

23 TECHNICAL DATA

Screw, retaining bracket, angle sensor	M6	10 Nm (7.4 lbf ft)
Screw, voltage regulator	M6	6 Nm (4.4 lbf ft)
Screw, wheel speed sensor, rear	M6	10 Nm (7.4 lbf ft)
Remaining chassis nuts	M8	25 Nm (18.4 lbf ft)
Remaining chassis screws	M8	25 Nm (18.4 lbf ft)
Screw, bottom triple clamp	M8	12 Nm (8.9 lbf ft)
Screw, foot brake lever	M8	25 Nm (18.4 lbf ft) Loctite®243™
Screw, fork stub	M8	15 Nm (11.1 lbf ft)
Screw, front footrest bracket	M8	25 Nm (18.4 lbf ft) Loctite®243™
Screw, handle bar end hand guard	M8	25 Nm (18.4 lbf ft)
Screw, handlebar clamp	M8	20 Nm (14.8 lbf ft)
Screw, ignition lock (tamper-proof screw)	M8	25 Nm (18.4 lbf ft) Loctite®243™
Screw, rear footrest bracket	M8	25 Nm (18.4 lbf ft) Loctite®243™
Screw, steering damper	M8	25 Nm (18.4 lbf ft) Loctite®243™
Screw, steering damper clamp	M8	12 Nm (8.9 lbf ft)
Screw, steering stem	M8	20 Nm (14.8 lbf ft)

Screw, suitcase hook	M8	20 Nm (14.8 lbf ft) Loctite®243™
Screw, top triple clamp	M8	20 Nm (14.8 lbf ft)
Remaining chassis nuts	M10	45 Nm (33.2 lbf ft)
Remaining chassis screws	M10	45 Nm (33.2 lbf ft)
Screw, front brake caliper	M10	45 Nm (33.2 lbf ft) Loctite®243™
Screw, handlebar support	M10	40 Nm (29.5 lbf ft) Loctite®243™
Screw, side stand	M10	35 Nm (25.8 lbf ft) Loctite®243™
Screw, side stand bracket	M10	45 Nm (33.2 lbf ft) Loctite®243™
Banjo bolt, brake line	M10x1	25 Nm (18.4 lbf ft)
Nut, rear sprocket screw	M10x1.25	50 Nm (36.9 lbf ft) Loctite®243™
Lambda sensor	M12x1.25	25 Nm (18.4 lbf ft)
Screw, bottom shock absorber	M14x1.5	80 Nm (59 lbf ft) Thread greased
Screw, top shock absorber	M14x1.5	80 Nm (59 lbf ft) Thread greased
Nut, socket	M18x1	4 Nm (3 lbf ft)

23 TECHNICAL DATA

Nut, swingarm pivot	M19x1.5	130 Nm (95.9 lbf ft) Thread greased
Nut, seat lock	M22x1.5	4 Nm (3 lbf ft)
Screw, steering head, top	M22x1.5	18 Nm (13.3 lbf ft)
Nut, rear wheel spindle	M25x1.5	90 Nm (66.4 lbf ft) Thread greased
Screw, front wheel spindle	M25x1.5	45 Nm (33.2 lbf ft) Thread greased

24.1 Declarations of conformity



Info

The functional and equipment scope is model-dependent and may not include all wireless systems and application areas referred to.

COBO SpA hereby declares that the **BT-ROUTER** wireless system conforms with the relevant guidelines. The full text of the Declaration of Conformity is available at the following Internet address.

Certification website: <http://www.ktm.com/btrouter>

JNS Instruments Ltd. hereby declares that the **210M1100** wireless system conforms with the relevant guidelines.

The full text of the Declaration of Conformity is available at the following Internet address.

Certification website: <http://www.ktm.com/210m1100>

KTM AG hereby declares that the **KTM RACE ON system** wireless system conforms with the relevant guidelines. The full text of the Declaration of Conformity is available at the following Internet address.

Certification website: <http://www.ktm.com/ktm-race-on-system>

KTM AG hereby declares that the **LC8 DASHBOARD** wireless system conforms with the relevant guidelines. The full text of the Declaration of Conformity is available at the following Internet address.

Certification website: <http://www.ktm.com/lc8-dashboard>

Schrader Electronics Ltd hereby declares that the **Tyre Pressure Monitoring System** wireless system conforms with the relevant guidelines. The full text of the Declaration of Conformity is available at the following Internet address.

Certification website: <http://www.ktm.com/tpms>

24 DECLARATIONS OF CONFORMITY

210M1100

FCC ID: 2AKR7-210M1100

IC: 22291-210M1100

BT-ROUTER

FCC ID: Z64-2564N

IC: 4511-2564N

KTM RACE ON system - Active Key

FCC ID: VFZKLGKZADIO1

IC: 22239-KLGKZADIO1

KTM RACE ON system - Main Unit

FCC ID: VFZKLGZADIO1

IC: 22239-KLGMZADIO1

LC8 DASHBOARD

FCC ID: 2AKP9-LC8CLUSTER1

IC: 22273-LC8CLUSTER1

Tyre Pressure Monitoring System - Receiver "MC34MA4"

FCC ID: MRXMC34MA4

IC: 2546A-MC34MA4

Tyre Pressure Monitoring System - Sensor "BC5A4"

FCC ID: MRXBC5A4

IC: 2546A-BC5A4

Tyre Pressure Monitoring System - Sensor "RDC3"

FCC ID: MRXRDC3

IC: 2546A-RDC3

Declaration regarding modifications

Alterations and modifications not expressly approved by the relevant authority may result in the user being prohibited from operating the equipment.

Declaration regarding interference

This device fulfills Part 15 of the FCC regulations as well as the license-free RSS standards of the Canadian Government Department **Industry Canada**.

Operation is subject to the following two conditions:

- 1 This device must not cause interference.
- 2 This device must be able to absorb any interference, including interference that potentially causes undesirable operation of the device.

Note on radio transmissions

This device corresponds to the FCC limit values for radiation exposure, which have been determined for a non-controlled environment, and fulfills the FCC guidelines for the load from radio frequencies.

The transmitter must not be set up near to other antennas or transmitters or operated in conjunction with other antennas or transmitters.

Note on digital devices of Class B according to the FCC regulations

This device has been tested and fulfills the limit values for digital devices of Class B according to the FCC regulations, Part B.

These limit values are designed so as to provide sufficient protection from harmful interference in residential areas.

Devices of this type generate and use high frequencies and can also emit these. Therefore, if they are not installed and operated in accordance with the instructions, they may cause harmful interference to radio reception. However, there is no guarantee that interference will not occur in certain cases of application. Should this device cause harmful interference to radio or television reception, (check this by switching the device on and off), you can potentially eliminate this interference as follows:

24 DECLARATIONS OF CONFORMITY

- Re-align the receiving antenna.
- Increase the distance between device and radio receiver.
- Connect the device and the radio receiver to separate electric circuits.
- Consult your dealer or a radio/TV technician.

CAN ICES-3 (B) / NMB-3 (B)

This digital device of Class B fulfills the regulations in accordance with the Canadian Interference-Causing Equipment Standard ICES-003 / NMB-003.

25.1 Information on open source software

Some vehicle components use open source software.

The source code of the software used and other information are available online.

Overview: <http://www.ktm.com/ktm-oss>



Info

Due to the file size, the download may take a long time.

Depending on the Internet provider, costs may arise due to the data volume.

Brake fluid DOT 4 / DOT 5.1

Standard/classification

- DOT

Guideline

- Use only brake fluid that complies with the specified standard (see specifications on the container) and that exhibits the corresponding properties.

Recommended supplier

Castrol

- **REACT PERFORMANCE DOT 4**

Motorex®

- **Brake Fluid DOT 5.1**

Coolant

Guideline

- Only use high-grade, silicate-free coolant with corrosion inhibitor additive for aluminum motors. Low grade and unsuitable antifreeze causes corrosion, deposits and frothing.
- Do not use pure water as only coolant is able to meet the requirements needed in terms of corrosion protection and lubrication properties.
- Only use coolant that complies with the requirements stated (see specifications on the container) and that has the relevant properties.

Antifreeze protection to at least	-25 °C (-13 °F)
-----------------------------------	-----------------

The mixture ratio must be adjusted to the necessary antifreeze protection. Use distilled water if the coolant needs to be diluted.

The use of premixed coolant is recommended.

Observe the coolant manufacturer specifications for antifreeze protection, dilution and miscibility (compatibility) with other coolants.

Recommended supplier

Motorex®

- **COOLANT M3.0**

Engine oil (SAE 10W/50)

Standard/classification

- JASO T903 MA (📖 p. 350)
- SAE (📖 p. 350) (SAE 10W/50)

Guideline

- Use only engine oils that comply with the specified standards (see specifications on the container) and that possess the corresponding properties.

Fully synthetic engine oil

Recommended supplier

Motorex®

- **Power Synt 4T**

Engine oil (SAE 5W/40)

Standard/classification

- JASO T903 MA (📖 p. 350)
- SAE (📖 p. 350) (SAE 5W/40)

Guideline

- Use only engine oils that comply with the specified standards (see specifications on the container) and that possess the corresponding properties.

Synthetic engine oil

Recommended supplier

Motorex®

- Power Synt 4T

Fork oil (SAE 4) (48601166S1)

Standard/classification

- SAE (📖 p. 350) (SAE 4)

Guideline

- Use only oils that comply with the specified standards (see specifications on the container) and that exhibit the corresponding properties.

Shock absorber fluid (SAE 2.5) (50180751S1)

Standard/classification

- SAE (📖 p. 350) (SAE 2.5)

Guideline

- Use only oils that comply with the specified standards (see specifications on the container) and that exhibit the corresponding properties.

Super unleaded (ROZ 95/RON 95/PON 91)**Standard/classification**

- DIN EN 228 (ROZ 95/RON 95/PON 91)

Guideline

- Only use unleaded super fuel that matches or is equivalent to the specified fuel grade.
- Fuel with an ethanol content of up to 10 % (E10 fuel) is safe to use.

**Info**

Do **not** use fuel containing methanol (e. g. M15, M85, M100) or more than 10 % ethanol (e. g. E15, E25, E85, E100).

Chain cleaner

Recommended supplier

Motorex®

- Chain Clean

Chain lube for road use

Guideline

Recommended supplier

Motorex®

- Chainlube Road

Fuel additive

Recommended supplier

Motorex®

- Fuel Stabilizer

Long-life grease

Recommended supplier

Motorex®

- Bike Grease 2000

Motorcycle cleaner

Recommended supplier

Motorex®

- Moto Clean

Perfect Finish and high gloss polish for paints

Recommended supplier

Motorex®

- Moto Polish & Shine

Preserving materials for paints, metal and rubber

Recommended supplier

Motorex®

- Moto Protect

Special cleaner for glossy and matte paint finishes, metal and plastic surfaces

Recommended supplier

Motorex®

- Quick Cleaner

Universal oil spray

Recommended supplier

Motorex®

- Joker 440 Synthetic

JASO T903 MA

Different technical development directions required a separate specification for motorcycles – the **JASO T903 MA** standard.

Earlier, engine oils from the automobile industry were used for motorcycles because there was no separate motorcycle specification.

Whereas long service intervals are demanded for automobile engines, the focus for motorcycle engines is on high performance at high engine speeds.

In most motorcycle engines, the transmission and clutch are lubricated with the same oil.

The **JASO MA** standard meets these special requirements.

SAE

The SAE viscosity classes were defined by the Society of Automotive Engineers and are used for classifying oils according to their viscosity. The viscosity describes only one property of oil and says nothing about quality.

ABS	ABS	Safety system that prevents locking of the wheels when driving straight ahead without the influence of lateral forces
ATIR	Automatic Turn Indicator Reset	Software, which automatically switches the indicator off according to a time or travel distance counter
DRL	Daytime Running Light	Light, which enhances the visibility of the vehicle during the day but is not focused, and in contrast to low beam does not illuminate the road surface
HHC	Hill Hold Control	Assist, which prevents the vehicle from rolling backwards on an incline
	KTM RACE ON	System which releases ignition, steering lock and filler cap via a remote key with transponder
MSR	Motor Slip Regulation	Auxiliary function of the motor control, which prevents rear wheel locking with excessive engine braking effect, by lightly opening the throttle valve
MSC	Motorcycle Stability Control	The is an auxiliary function for the ABS, which can prevent blocking and slipping of the wheels during braking on an inclined position, within the physical limitations
MTC	Motorcycle Traction Control	Auxiliary function of the motor control that reduces engine torque with spinning rear wheel
OBD	On-board diagnosis	Vehicle system, which monitors the specified parameters of the vehicle electronics

29 INDEX OF SPECIAL TERMS

	Quickshifter+	Engine electronics function for shifting up and down without clutch actuation
TPMS	Tire Pressure Monitoring System	Safety system, which monitors tire air pressure, with the help of sensors in the tire, and displays it to the rider

Art. no.	Article number
ca.	circa
cf.	compare
e.g.	for example
etc.	et cetera
i.a.	inter alia
no.	number
poss.	possibly





31.1 Red symbols

Red symbols indicate an error condition that requires immediate intervention.

	The oil pressure warning lamp lights up red – The oil pressure is too low. Stop immediately, taking care not to endanger yourself or other road users in the process, and switch off the engine.
---	--

31.2 Yellow and orange symbols





Yellow and orange symbols indicate an error condition that requires prompt intervention. Active driving aids are also represented by yellow or orange symbols.

	Race-on indicator lamp lights up/flashes yellow/orange/red – Status or error messages relating to Race-on system/alarm system.
	The general warning lamp lights up yellow – An operating safety (warning note) message was detected. This is also shown on the display.
	ABS indicator lamp lights up yellow – Status or error messages relating to ABS. The ABS indicator lamp flashes if the ABS mode Offroad is enabled.
	TC indicator lamp lights up/flashes yellow – The MTC (📖 p. 295) is not enabled or is currently intervening. The TC indicator lamp also lights up if an error is detected. Contact an authorized KTM workshop. The TC indicator lamp flashes if TC actively engages or if the HHC (📖 p. 162) (optional) is activated.
	The cruise control system indicator lamp lights up yellow – The cruise control system function is switched on, but the speed control is not active.

	Malfunction indicator lamp lights up yellow – The OBD has detected an emission- or safety-critical fault.
---	---

31.3 Green and blue symbols

Green and blue symbols reflect information.

	The left turn signal indicator lamp flashes green with a steady rhythmic flash – The left turn signal is switched on.
	The high beam indicator lamp lights up blue – The high beam is switched on.
	The idle indicator lamp lights up green – The transmission is in idle.
	The cruise control system indicator lamp lights up green – The cruise control system function is switched on and the speed control is active.
	The right turn signal indicator lamp flashes green with a steady rhythmic flash – The right turn signal is switched on.

A	
ABS	231
ACC1	
front	287
rear	288
ACC2	
front	287
rear	288
Accessories	27
Antilock brake system	231
Auxiliary substances	27
B	
Battery	
installing	268
recharging	271
removing	266
Brake discs	
checking	234
Brake fluid	
front brake, adding	236
rear brake, adding	241
Brake fluid level	
front brake, checking	235
rear brake, checking	240
Brake linings	
front brake, checking	239
rear brake, checking	244
Brake system	231-244
Brakes	170
Brakes, applying	170
C	
Capacity	
coolant	326
engine oil	301, 326
fuel	178, 327
Case holders	59
Center stand	63
Chain	
checking	201
checking for dirt	196
cleaning	196
Chain tension	
adjusting	199
checking	198

Chassis number	34	General Info	108
Clutch		Headset Pass.	101
fluid level, checking/correcting	204	Headset Rider	99
Clutch lever	38	heated grip (optional)	81
basic position, adjusting	139	Heated Grips (optional)	112, 132
Combination instrument	64-134	Heated Seat (optional)	113
ABS	117	Heated Seat Pas (optional)	133
ABS display	79	Heated Seat Rid (optional)	132
activation and test	65	HHC (optional)	119
adjusting tilt	149	ice warning	69
ambient air temperature indicator	83	indicator lamps	70
Audio	88	Info	105
Bluetooth	96	KTM MY RIDE	87
Consumption	126	Language	126
coolant temperature indicator	82	menu	87
Cornering Light Test	133	Motorcycle	112
cruise control indicator	78	MTC	115
day-night mode	67	MTC display	80
display	74	MTC+MSR (optional)	116
Distance	124	navigation	90
DRL	130	Navigation display	86
Extra Functions	111	Navigation Info Screen	120
Favourites	120	navigation information	93
Favourites display	84	navigation setup	91
fuel level display	82	overview	64

Phone	97	Warnings	110
Preferences	123	Wireless Interface	103
Pressure	125	Combination switch	
Quick Selector 1	121	left side	39
Quick Selector 1 display	85	overview left side	40
Quick Selector 2	122	overview right	47
Quick Selector 2 display	85	right	46
Quickshifter + (optional)	131	Coolant level	
Ride display	80	compensating tank, checking	289
Ride Mode	114, 294	correcting in the compensating tank	291
seat heater (optional)	81	Cornering headlight	265
Service	110	Crash bar	
Settings	119	installing	228
Setup	95	removing	227
shift warning light	77	Cruise control system	
speed	76, 79	operation	41
telephony	104	Customer service	28
Temperature	124	D	
time	84	Date	
TPMS	108	setting	128
Trip 1	106	Daytime running light	264
Trip 2	107	Declarations of conformity	339-342
Units	123	Diagnostics connector	287
volume	94		
Warning notes	68		

Driving	163	Filler cap	
DRL	264	closing	55
E		opening	53
Electric starter button	48	Foot brake lever	61
Emergency OFF switch	48	basic position, adjusting	148
Engine		Footrests	
running in	153	adjusting	141
Engine guard		Fork	183
installing	226	compression damping, adjusting	183
removing	226	dust boots, cleaning	219
Engine number	36	rebound, adjusting	185
Engine oil		Spring pretension, adjusting	186
adding	304	Fork part number	36
changing	297	Front fender	
Engine oil level		installing	218
checking	296	removing	218
Engine sprocket		Front side cover	
checking	201	installing	210
Engine traction torque control	169	removing	209
Environment	26	Front wheel	
F		installing	247
Figures	28	removing	245
		Fuel cocks	56

Fuses	
in fuse box, changing	280
G	
Grab handles	58
H	
Hand brake lever	38
basic position, adjusting	140
Handlebar position	135
adjusting	135
Hazard warning flasher	47
Hazard warning flasher switch	47
Headlight	
daytime running light	264
range, adjusting	286
Headlight setting	
checking	285
Horn button	46
I	
Ice warning	69
Immobilizer	51
Indicator lamps	70
Intended use	13
K	
Key number	35
L	
Light switch	40
Luggage	153
Luggage rack plate	58
M	
Main fuse	
changing	277
Mask spoiler	
installing	215
removing	211
Misuse	13
Motorcycle	
cleaning	307
Motorcycle traction control	295
MSR	169
MTC	295
O	
Oil filter	
changing	297

Oil screens	
cleaning	297
Open source	
information	343
Open source	
information	343
Operating substances	27
Owner's Manual	26
P	
Parking	173
Passenger footrest	60
Preparing for use	
advice on preparing for first use	151
after storage	314
checks and maintenance measures when	
preparing for use	156
Protective clothing	25
Q	
Quickshifter +	161
R	
Race-on key	51
battery, changing	276
Race-on tip switch	49
Rear hub rubber dampers	
checking	257
Rear sprocket	
checking	201
Rear wheel	
installing	254
removing	251
Refueling	
fuel	176
Rider footrests	140
Riding	
starting off	160
starting off with HHC (optional)	162
S	
Safe operation	24
Seat	
mounting	195
removing	195
Seat lock	57
Service	28
Service schedule	179-182

Shift lever	60	Stopping	173
basic position, adjusting	145	Storage	312
basic position, checking	144	Storage compartment	
Shift lever stub		closing	57
adjusting	147	opening	56
Shifting	163	USB socket	53
Shock absorber	183	Suspension setting	183-192
compression damping	187	T	
high-speed compression damping, adjusting .	189	Tank cover	
low-speed compression damping, adjusting .	188	installing	223
rebound damping, adjusting	191	removing	220
spring pretension, adjusting	192	Technical data	
Shock absorber article number	37	capacities	326
Side stand	62	chassis	327
Socket for electrical accessories	52	chassis tightening torques	333
Spare parts	27	electrical system	328
Spoke tension		engine	319-338
checking	262	engine tightening torques	321
Starting	157	fork	330
Steering damper article number	37	shock absorber	331
Steering head bearing play		tires	330
checking	206	Throttle grip	39
Steering lock	50		

Time	
adjusting	128
Tire air pressure	
checking	261
Tire condition	
checking	258
Transporting	175
Triple clamp cover, bottom	
installing	208
removing	207
Troubleshooting	315-318
Tubeless tire system	263
Turn signal bulb	
changing	283
Turn signal switch	44
Type label	34
U	
USB socket	53
Use definition	13
V	
Vehicle	
loading	153
	raising with the center stand
	193
	removing from the center stand
	194
View of vehicle	
front left	30
rear right	32
W	
Warranty	27
Wind shield	
installing	225
removing	225
Windshield	
adjusting	138
Winter operation	
checks and maintenance steps	310
Work rules	25

READY TO RACE

[» www.ktm.com](http://www.ktm.com)



3213754en

10/2017

KTM Sportmotorcycle GmbH
3230 Mattighofen/Austria
<http://www.ktm.com>



Photo: Mitterbauer/KTM