

DRIVER ASSURANCE

Mazda Drivers Assurance Plan
Check out www.mymazda.com, the website dedicated to you. Manage your maintenance records, receive valuable offers, see the latest accessories, and much more!

Mazda Roadside Assistance
Exhilaration, liberation and inspiration, are great reasons to drive a Mazda car, truck, SUV or minivan. In addition to all the other great standard features, you also get peace of mind, our Emergency Roadside Assistance Plan, it's just a phone call away, 24 hours a day, 365 days a year, call **1-800-866-1998**

Mazda "bumper-to-bumper" Limited Warranty
We design and build every Mazda to give you driving pleasure now and far down the road. We're so confident in our quality that we cover the entire vehicle against defects in materials and workmanship

for 48 months or 50,000 miles, whichever comes first
Mazda Service Transportation Solution
Being without your Mazda may put a crimp in your day, if you do ever have to take your Mazda in for repairs don't worry, you're covered. With the Mazda Transportation Solution, you will be given a loaner car at no charge when your Mazda vehicle is in for warranty repairs. For all the details, see your Mazda Dealer

This Quick Tips® guide is provided by Mazda North American Operations to make your Mazda ownership experience more convenient. It is not intended to replace your Owner's Manual. If you have any questions about your vehicle, you are invited to contact your local dealer. Or if you need additional help, feel free to call our **Customer Assistance Center at 1-800-222-5500** Monday through Friday, 9 a.m. - 4:45 p.m., Pacific 9 a.m. - 5:45 p.m., Eastern/Central

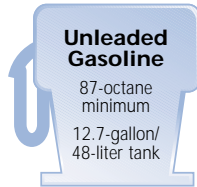

©2003 Calcar. Quick Tips® is a trademark of Calcar, made in USA 6/03 21.385M DOT Mazda North American Operations reserves the right to change product specifications at any time without incurring obligations. 9999-95-031C-04QT

2004

MAZDA MX-5 MIATA

Quick Tips®

Reference
Guide for
Controls and
Functions

DRIVER'S VIEW

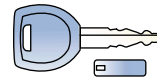
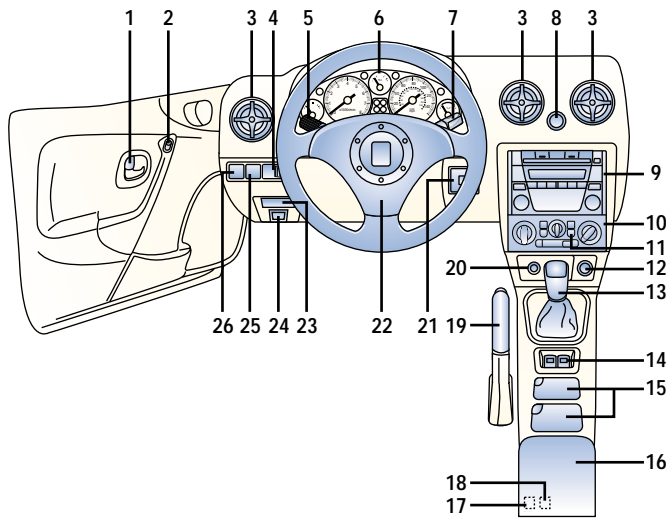

Key/number plate
Operates ignition and all locks

Tip: Use key number plate to purchase a new key; store in a safe place separate from vehicle

Immobilizer system
Prevents engine from running unless coded key used; see Owner's Manual

Remote entry system*, see Switches/Locks



- | | | |
|--|--|---|
| <p>1. Manual door locks, see Switches/Locks</p> <p>2. Power door locks*, see Switches/Locks</p> <p>3. Air vents
Move vents to direct airflow</p> <p>4. Instrument panel lighting selector, see Interior Lights/Console</p> <p>5. Turn signal/lighting control lever, see Driver Controls</p> <p>6. Instrument cluster, see Instrument Cluster</p> <p>7. Wiper/washer/Cruise control* lever, see Driver Controls</p> <p>8. Hazard warning switch
Press on/off</p> | <p>9. Audio system, see Audio Systems</p> <p>10. Climate control system, see Climate Controls</p> <p>11. Rear window defogger switch
Press on/off</p> <p>12. Cigarette lighter</p> <p>13. Gearshift lever, see Transmission</p> <p>14. Power-window switches, see Switches/Locks</p> <p>15. Ashtray/cup holder</p> <p>16. Center console, see Interior Lights/Console</p> <p>17. Fuel door release lever
Pull to open fuel door</p> <p>18. Remote trunk-lid release
Pull to open trunk</p> | <p>19. Parking-brake lever, see Interior Lights/Console</p> <p>20. Passenger-side air bag deactivation switch, see Child Seats</p> <p>21. Power outside mirror switch, see Switches/Locks</p> <p>22. Horn/air bag
Press for horn</p> <p>23. Fuse panel</p> <p>24. Hood release handle
Pull to open partially</p> <p>25. Cruise control main switch*, see Driver Controls</p> <p>26. Fog light switch, see Driver Controls</p> |
|--|--|---|

*Denotes optional equipment

Always check the Owner's Manual for more operating information and safety features

Driver's
View

Instrument Cluster

INSTRUMENT CLUSTER

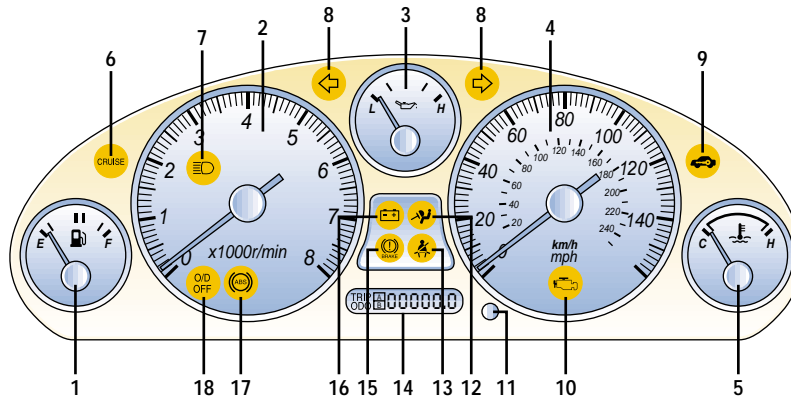

GAUGES

1. **Fuel gauge**
12.7-gallon/48-liter tank
2. **Tachometer**
Avoid red zone
3. **Engine oil pressure gauge**
If outside normal range, stop vehicle safely and turn off engine, check oil level
4. **Speedometer**
5. **Coolant temperature gauge**
If above normal range, stop vehicle safely and turn off engine; check coolant level when safe

WARNING LIGHTS

6. **CRUISE Cruise control on***
Lights when cruise control is set
7. **High beams on,**
see Driver Controls

8. **Turn signal/hazard warning on**
9. **Immobilizer system on,** see Driver's View
10. **Check engine**
Dealer inspection required
11. **Odometer/trip odometer selector**
Press to select odometer or trip odometer A/B; press and hold to reset selected trip odometer
12. **Air bag readiness**
If light flashes or stays on, the air bags may not operate in an accident; dealer inspection required
13. **Always fasten safety belts**

14. **Odometer/trip odometer display**
15. **Brake system**
Parking brake on/low brake fluid
16. **Charging system warning light**
Possible alternator or charging system malfunction, dealer inspection required
17. **Anti-lock Brake System (ABS)***
Indicates ABS malfunction, dealer inspection required
18. **Overdrive off indicator (Automatic transmission)***
Lights when the overdrive button is in the off position

*Denotes optional equipment

Always check the Owner's Manual for more operating information and safety features

Instrument Cluster

Driver Controls

DRIVER CONTROLS

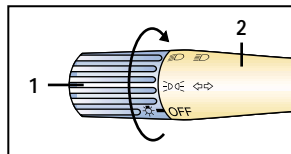

Turn signal/lighting control lever

OFF = Lights off

☺☺ = Tail, parking and dashboard lights on: Rotate knob to (1) first notch

☺☺☺ = Tail, parking, dashboard and headlights on: Rotate knob (1) to second notch

High beams on/off: Push lever (2) forward to detent/pull back

To flash high beams: Pull lever (2) toward you and release

Fog lights

Press (3) on/off; functions only with headlight low beams on

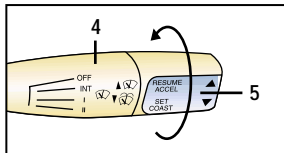

Windshield wiper/washer/Cruise control* lever

For slow/normal/fast wiper speeds: Push lever (4) down through detents

Single wipe: Set the wipers to OFF; push lever (4) forward Wash and wipe: Pull lever (4) toward you and hold; washer and wipers will be activated until lever is released

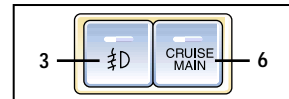

Cruise control*

Operates above 25 mph Press CRUISE MAIN switch (6) to enable/disable

To set speed: Twist control knob (5) down toward SET/COAST ▼ and release

To increase set speed: Twist control knob (5) up toward RESUME/ACCEL ▲ and release at desired speed

To decrease set speed: Twist control knob (5) down toward SET/COAST ▼ and release at desired speed

To cancel: Tap brake or clutch pedal (manual transmission) or press CRUISE MAIN switch (6)

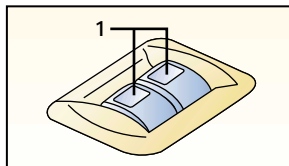

Power windows

Operate only with ignition on To open/close: Push down/pull up front of switch (1)

Press driver window button down once for one touch auto down

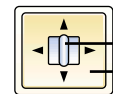

Dual power mirrors

Operate only with ignition on

To adjust left/right mirror: Push selector switch (2) left/right, press switch (3) in direction of desired movement

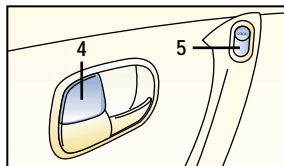

Manual door locks

To lock/unlock: Push button (4) into handle/pull toward you

Power door locks*

Both doors lock/unlock by using key in driver's door or by using driver's button (5)

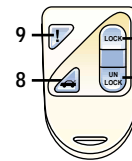

Remote keyless entry system

Functions only with ignition in OFF position

To lock doors: Press LOCK button (6); pressing again within 5 seconds causes doors to relock and horn to beep

To unlock: Press UNLOCK (7) for driver's door; press again within 5 seconds to unlock other door

To open trunk: Press (8)

Panic alarm: Press ! (9); horn sounds, headlights/taillights flash; to stop, press any remote button

*Denotes optional equipment

Always check the Owner's Manual for more operating information and safety features

Switches/
Locks

Interior Lights/
Console

INTERIOR LIGHTS/CONSOLE

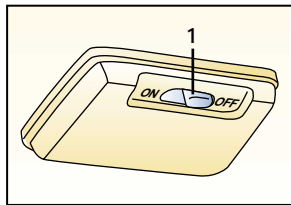

1. Dome light

On = Light always on
Off = Light always off
Center position = Light on when a door is open

2. Instrument panel lighting

To brighten/dim instrument panel lighting: Turn thumb-wheel right/left

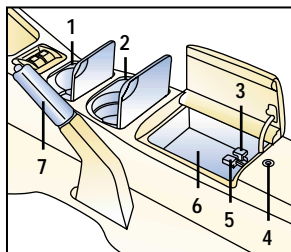
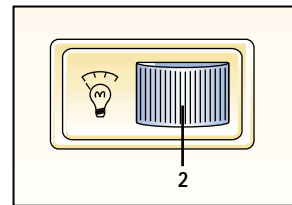

Center console

1. Ashtray/Cup holder

Pull up ashtray to remove; space can be used as a cup holder

2. Cup holder

3. Remote trunk-lid release

To open trunk: Lift up on front of lever

4. Center console lock

To lock/unlock: Insert key and turn clockwise/counterclockwise

5. Remote fuel door release

To open fuel door: Lift up on front of lever

6. Center console storage

7. Parking-brake

To engage: Pull up
To release: Pull up slightly while depressing button at the front of lever; lower parking-brake lever

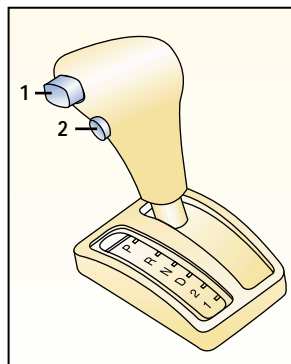

Automatic transmission*

P = Park

To move gearshift from Park: Press firmly on brake pedal, then press release button (1) on gearshift

R = Reverse

Do not engage Reverse when vehicle is moving forward

N = Neutral

No gear engaged; vehicle can roll freely, even on a slight incline, unless the brakes are applied

Overdrive Switch

Press (2) to lockout/enable overdrive

D (Overdrive)

For normal driving: Shifts through four forward gears automatically

D (Overdrive Off)

Shifts through three forward gears automatically
Provides extra power and increased engine braking, stops 3rd-4th gear cycling in stop/go driving and on steep graded hills

2 = Second gear

Provides extra power and increased engine braking
Use to reduce wheel spin when starting on slippery surfaces

1 = First gear

Use for engine braking when second gear is not sufficient



5-speed

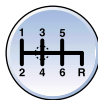

6-speed

Manual transmission

Depress clutch pedal to start engine and change gears

Tip: Do not shift into 1st above 20 mph or clutch failure could occur

Tip: Resting your foot on the clutch pedal while driving and using the clutch to hold your vehicle at a standstill while waiting on a hill may reduce clutch life

*Denotes optional equipment

Always check the Owner's Manual for more operating information and safety features

Transmission

Seats

SEATS

Manual controls**1. Fore-aft adjustment**

Lift lever and hold, slide seat, release lever

2. Safety belt buckle**3. Seatback angle**

To adjust: Lift and hold lever, lean forward or backward, release lever

⚠ WARNINGS: Do not adjust seats while driving

Safety belts must always be worn when vehicle is in motion

All air bags are supplemental and do not replace safety belt usage

Always wear your safety belt and properly secure children

**Safety belt emergency locking mode/automatic locking mode**

(front passenger seat only)

Emergency locking mode:

Belt locks only on hard braking/cornering or impacts of about 5 mph or more

Automatic locking mode:

Must be used when installing child-safety seat (see below)

To activate: Pull webbing fully out of retractor until click is heard; belt will only tighten

To disengage: Unbuckle belt and allow webbing to retract fully

* Denotes optional equipment

† For other rare circumstances when passenger air bag can be shut off, refer to NHTSA guidelines

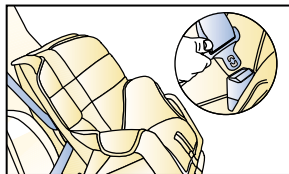
**Child-safety seat***

To install in passenger seat: Move seat as far back as possible; use dual locking mode retractor safety belt; see Owner's Manual for proper installation of child seat and LATCH system instructions

⚠ WARNING: Use age appropriate child restraints, see Owner's Manual and state or province laws

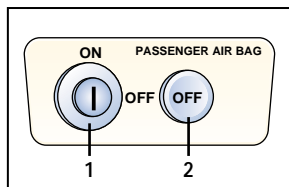
**Passenger's seat air bag deactivation switch,**

see Driver's View for switch location

Deactivate passenger's seat air bag when using a child-safety seat

To deactivate/activate: Insert ignition key in switch, rotate to OFF/ON, remove key

Amber OFF light illuminates when deactivated and ignition is on

💡 Tip: Turn ignition off when disabling passenger front air bag

⚠ WARNINGS: When using a rear-facing infant-safety seat always set the passenger seat air bag deactivation switch to OFF position, an infant is in serious danger of being injured or killed if front passenger air bag is deployed

If you choose to install a forward-facing child-safety seat in the front seating position, move vehicle seat as far back as possible and set air bag deactivation switch to OFF position

Always check the Owner's Manual for more operating information and safety features

Child Seats

Climate Controls

CLIMATE CONTROLS

1. Temperature control

Rotate knob to blue for cool/red for warm

2. Air Conditioning

Press to turn on/off

Tip: Use A/C to dehumidify air

3. Fan control

Rotate knob to increase/decrease speed, turn to 0 to shut system off

4. Air intake control

Slide lever to select

= recirculate inside air; use for maximum heating/cooling or to keep odors out
 = fresh air

WARNING: Do not use position in cold weather; windows could fog and hamper vision

5. Rear window defogger

Press to activate/deactivate

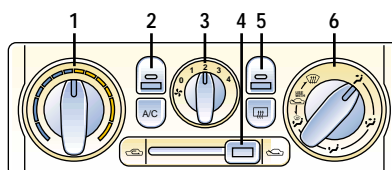

6. Airflow selections

- = air to dash
- = air to dash/floor
- = air to floor
- = air to floor/windshield, A/C compressor is on
- = defrost, air to windshield, A/C compressor is on

Control positions for maximum defrost

Fan to maximum, temperature to maximum hot, airflow selector knob to

Tips: When selected, air is dried by A/C compressor operation when temperature is above 39°F

To help prevent windshield fogging in humid weather, select before starting engine

To prevent moisture buildup, never drive with system off

WARNING: When using position always set temperature control to hot or warm to prevent glass fogging

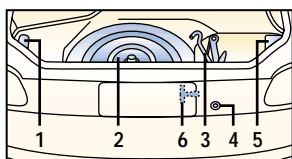

Trunk

1. Lug wrench/wheel lock key

2. Temporary spare tire

To change flat tire: Follow instructions in Owner's Manual

WARNING: Do not exceed 50 mph with temporary spare

Tip: Temporary spare tire should only be used for very short periods

3. Jack/jack handle

4. Lock
To lock/unlock: Insert key and turn counterclockwise/clockwise

5. Battery

Tire economy and tips

Check pressure at least monthly when tires are cold. Maintain correct front-end alignment and tire balance; rotate tires at 7,500-mile intervals; see Owner's Manual for rotation chart

Tire pressure

Decal on the edge of the driver's door provides tire pressure information

Tire chains*†

Tire chains can damage aluminum wheels; use on steel wheels only

Tip: Use only SAE class "S" chains; install only on rear tires; install as tightly as possible and retighten periodically. Never exceed 30 mph with tire chains

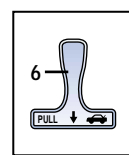

Trunk release handle

Allows you to escape should you become locked in trunk

To open: Pull "T" handle; "T" handle will glow if it has been exposed to light

WARNING: Always keep handle recessed; luggage may snag on handle and open trunk

*Denotes optional equipment
†See Owner's Manual

Always check the Owner's Manual for more operating information and safety features

Trunk

Convertible

C O N V E R T I B L E

Convertible top operation

- ☀️ **Tips:** Using an automatic car wash can damage top
- Storing articles inside near the rear window can cause damage to top upon lowering
- Windblocker* helps reduce wind entering cabin area with top down

To lower: Park on a level surface away from traffic lanes; set parking brake; lower side windows and pull down sunvisors, remove all objects from top storage area

Press unlock button (1); pull top latches (2) until they completely disengage from windshield header (3); lift up on front section of top (4); lower top into storage area; snap top latches (2) into closed position

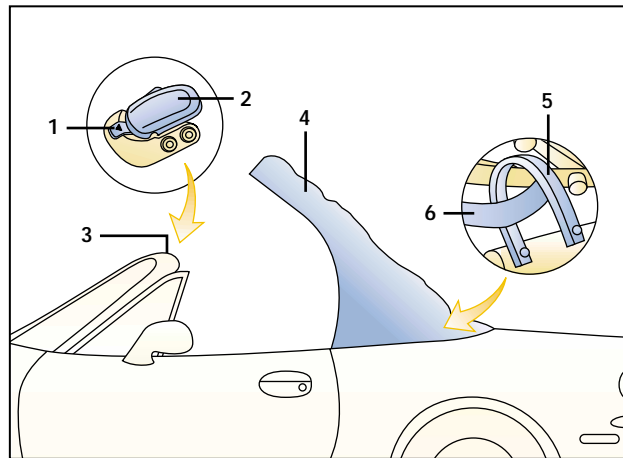

- ☀️ **Tips:** Do not store a wet or damp convertible top for long periods of time

Secure all objects inside vehicle before lowering top

To install convertible top cover: Thread tether straps (5) through anchor (6) and snap into position; attach top covering using fasteners; insert rear edges into body molding groove

To raise: Park on a level surface away from traffic lanes; set parking brake; lower side windows and pull down sunvisors

Open top latches (2) fully; lift top (4) until it rests on windshield header (3); fasten latches to windshield header by pushing up until click is heard

- ☀️ **Tip:** To ensure that top is securely fastened: Push up on top (4); if rattling is heard, repeat top latching process or have vehicle inspected by dealer

Detachable hardtop*

- ☀️ **Tip:** Perform hardtop installation or removal with two people

Park on a level surface away from traffic lanes; set parking brake and lower side windows; pull down sunvisors

To remove: Disconnect rear window defogger coupler; lower antenna; press unlock on top and side latches to release top; slide top rearward while pressing down on the rear deck latches; lift hard top straight off the body

To install: Lower antenna; fully lower convertible top; align rear latches with rear deck studs; slide hard top forward while pressing down on the rear deck; push up top and side latches to lock; reconnect rear window defogger

*Denotes optional equipment

Always check the Owner's Manual for more operating information and safety features

Convertible

Audio
Systems

AM / FM STEREO / CASSETTE / CD / MD

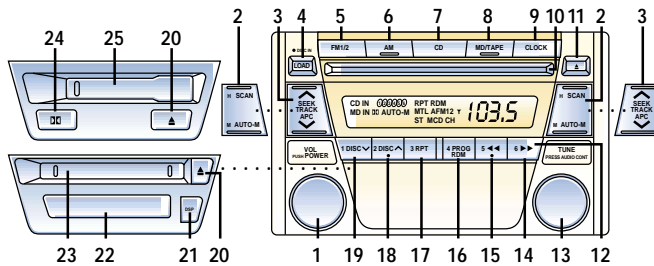
**1. Power/Volume**

Press on/off; rotate for volume

2. Scan/Auto-Memory

Press to briefly sample next listenable selections
Radio: Press and hold until a beep sound is heard; system automatically scans and temporarily stores six strong stations in each band; press again to cancel

6. AM

Press to select AM frequency band

7. CD

Press to play CD

8. MD*/Tape*

Press to play Mini-disc Player/cassette tape

Tip: MD player also plays MDLPs that have been recorded in MDLP mode

13. Tuning/Audio Control

Tune: Rotate counterclockwise/clockwise for lower frequency/higher frequency

Audio control: Press to select BASS/MID/TREBLE/FADE/BALANCE/ALC/TOP UP 1/TOP UP 2/TOP UP 3/TOP DOWN 1/TOP DOWN 2/TOP DOWN 3; rotate right/left to adjust selected feature

14. Fast forward ►►

Press to fast forward through a track

15. Reverse ◀◀

Press to reverse through a track

16. Program Random†

Press to enable/cancel random play, or to play other side of cassette tape

17. Repeat

Press to replay current CD/tape selection

3. SEEK/TRACK/APC

Radio: Press \wedge / \vee to automatically seek higher/lower frequency

CD: Press \wedge / \vee to select next/previous track

Tape: Press \wedge / \vee to automatically advance tape to beginning of next selection/replay selection; to stop this operation, press button again

4. LOAD*

To load multiple discs: Press and hold LOAD (4) until a beep sound is heard; insert CD when "In" is displayed

To eject disc: Press Eject (11)

To eject specific disc: Press and hold Eject (11) until beep is heard; within five seconds press the desired tray number 1-6 (12)

5. FM1/2

Press to select between FM1/FM2 station preset buttons (12)

9. Clock

To set: With ignition in ACC or ON position, press (CLOCK) and hold until beeper sounds, 12 Hr/24 Hr will be displayed; rotate (Audio Control Dial) to switch between 12 Hr/24 Hr, selection will flash; press (CLOCK) again; Hr ADJ will be displayed next with hour flashing; press H to set hour; then press (CLOCK) button; Min ADJ will be displayed next with minutes flashing; press M to set minutes; then press (CLOCK) to complete procedure

10. CD slot***11. CD eject button****12. Memory preset buttons**

To set: Tune to station, press and hold until a beep sound is heard

18. Disc up \wedge †

Press to skip forward to beginning of next CD

19. Disc down \vee †

Press to skip back to beginning of previous CD

20. Eject button***21. DISP*****22. Mini Disc display*****23. Mini Disc slot*****24. Dolby® Noise Reduction***

Reduces tape noise and hiss; press to activate/deactivate

25. Cassette door*

Tip: Audio system becomes inoperable if power is interrupted or radio is stolen, a CODE is required to unlock audio unit See Owner's Manual

*Denotes optional equipment

†For use with cassette tape player, MD player, or CD changer*

Always check the Owner's Manual for more operating information and safety features

Audio
Systems

Under Hood

UNDER HOOD

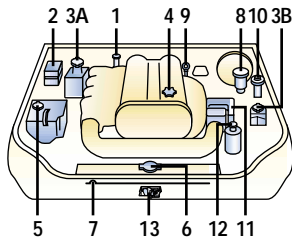

1.8-liter 4-cylinder

Tip: Check all fluids with vehicle parked on a level surface

1. Automatic transmission fluid dipstick*

If checked at operating temperature, fluid should be between FULL and LOW marks on dipstick; if checked with engine cold, fluid should be just below the bottom notch on dipstick

2. Fuse block

3. Windshield washer fluid reservoir

(A. Manual transmission)
(B. Automatic transmission)
Refill with windshield washer fluid

4. Engine oil filler cap, see Owner's Manual for recommended engine oil viscosity

5. Engine coolant reservoir
Check when engine is cold; fluid level should be between the FULL and LOW marks on reservoir

WARNING: Never remove coolant reserve tank cap while engine is running or hot; you could get burned

6. Radiator cap
Do not remove if engine is running or hot

7. Hood support rod

8. Brake fluid reservoir
If brake fluid level is low, have your vehicle inspected by your nearest Mazda dealer

9. Engine oil dipstick

Check with engine off and at operating temperature
Engine oil should be between F and L marks on dipstick

10. Clutch fluid reservoir (Manual transmission)

Level should be kept at the MAX mark on reservoir; fill with DOT 3 fluid from a sealed container

11. Air filter

12. Power steering fluid filler cap/dipstick

Check with engine off and at operating temperature
Level should be between H and L marks on the crosshatched area of dipstick

13. Hood latch

Pull up to release hood

Tip: Battery is located in the trunk

Break-in period

First 600 miles: Avoid heavy braking and acceleration; drive at varying road and engine speeds

Tip: Follow same procedures with overhauled engine or when brakes are replaced

Anti-lock Brake System (ABS)*

When brake pedal is pressed, ABS automatically reduces hydraulic pressure to any wheel on the verge of locking up
You may feel a slight pulsing of the brake pedal and hear a clicking noise; this tells you the ABS is functioning properly; increase pressure on pedal for maximum braking

Tips: Maintain constant pressure on the brake pedal
Do not pump the brakes

* Denotes optional equipment
† See Owner's Manual

NORMAL SERVICE INTERVALS

7,500 miles	A
15,000 miles	A
22,500 miles	A
30,000 miles	A B
37,500 miles	A
45,000 miles	A C
52,500 miles	A
60,000 miles	A B D
67,500 miles	A
75,000 miles	A C
82,500 miles	A
90,000 miles	A B

Unique driving conditions†

Every 5,000 miles change oil/filter, inspect coolant level, lights, brake/clutch fluid, tire pressure/wear, power steering fluid, locks/hinges and washer fluid

Normal maintenance notes

Rotate tires every 7,500 miles or sooner if needed

A. Change: Engine oil/replace filter
Lubricate: Locks and hinges

B. Inspect: Drive belts, fuel lines and hoses, idle speed, brake lines and hoses, disc brakes, steering operation and linkages, front suspension ball joints, driveshaft dust boots, chassis and body bolts, exhaust system and heat shields

Replace: Air filter, spark plugs

C. Change: Engine coolant

D. Inspect: Engine valve clearance, hoses and tubes for emission system

Replace: Engine timing belt, manual transmission oil, rear differential oil

Always check the Owner's Manual for more operating information and safety features