

DRIVER ASSURANCE

Mazda Drivers Assurance Plan
Check out www.mymazda.com, the website dedicated to you.

Manage your maintenance records, receive valuable offers, see the latest accessories, and much more!

Mazda Roadside Assistance

Exhilaration, liberation and inspiration, are great reasons to drive a Mazda car, truck, SUV or minivan. In addition to all the other great standard features, you also get peace of mind, our Emergency Roadside Assistance Plan, it's just a phone call away, 24 hours a day, 365 days a year, call **1-800-866-1998**

Mazda "bumper-to-bumper" Limited Warranty

We design and build every Mazda to give you driving pleasure now and far down the road. We're so confident in our quality that we cover the entire vehicle against defects in materials and workmanship

for 48 months or 50,000 miles, whichever comes first

Mazda Service Transportation Solution

Being without your Mazda may put a crimp in your day, if you do ever have to take your Mazda in for repairs don't worry, you're covered. With the Mazda Transportation Solution, you will be given a loaner car at no charge when your Mazda vehicle is in for warranty repairs.

For all the details, see your Mazda Dealer

This Quick Tips® guide is provided by Mazda North American Operations to make your Mazda ownership experience more convenient. It is not intended to replace your Owner's Manual.

If you have any questions about your vehicle, you are invited to contact your local dealer.

Or if you need additional help, feel free to call our

Customer Assistance Center at 1-800-222-5500

Monday through Friday,
9 a.m. - 4:45 p.m., Pacific
9 a.m. - 5:45 p.m., Eastern/Central

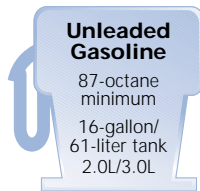

©2003 Calcar, made in USA 5/03 36.318M CG
Mazda North American Operations reserves the right to change product specifications at any time without incurring obligations.
9999-95-014C-04QT

2004

MAZDA TRIBUTE

Quick Tips®

Reference
Guide for
Controls and
Functions

DRIVER'S VIEW

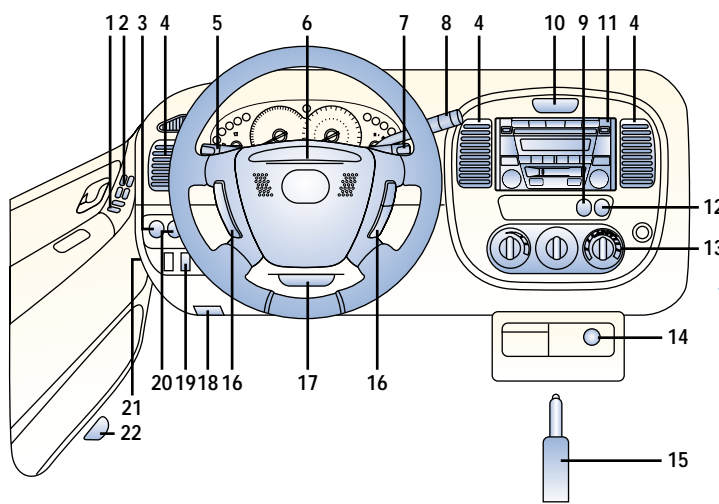
**Key**

Operates ignition and all locks

SecuriLock™ passive anti-theft key

Coded transistor in key activates ignition

Remote keyless entry system*, see Locks

 **Tips:** Use key number plate to purchase a new key; store in safe place. You can lock the lift-gate by using the key, pushing the lock button down or using the power door lock switch* on the left side of the cargo area

1. **Power door locks**, see Switches/Locks
2. **Power window switches**, see Switches/Locks
3. **Fog lamp switch***
Press on/off; on with low beams only
4. **Air vents**
5. **Turn signals/lighting control lever**, see Driver Controls
6. **Horn/Air bag**
7. **Wiper/washer control lever**, see Driver Controls

8. **Gearshift lever (A/T)**, see Transmission
9. **Rear window defogger**
Press on/off; shuts off with ignition or after 10 minutes
10. **Hazard warning switch**
Push on/off
11. **Audio system**, see Audio Systems
12. **4x4 control***, see Transmission
13. **Climate control panel**, see Climate Controls
14. **Auxiliary power point**

15. **Parking brake lever**
16. **Cruise control***, see Overhead Console
17. **Tilt steering-wheel lever**
Push release lever down, tilt wheel up or down, pull lever up to lock
18. **Hood release handle**
Pull to open partially
19. **Instrument panel lighting**
To brighten/dim: Rotate thumb-wheel up/down
20. **Dual power mirrors**, see Switches/Locks
21. **Fuse panel**
22. **Fuel filler door release**

*Denotes optional equipment

Always check the Owner's Manual for more operating information and safety features

Driver's
View

Instrument Cluster

INSTRUMENT CLUSTER

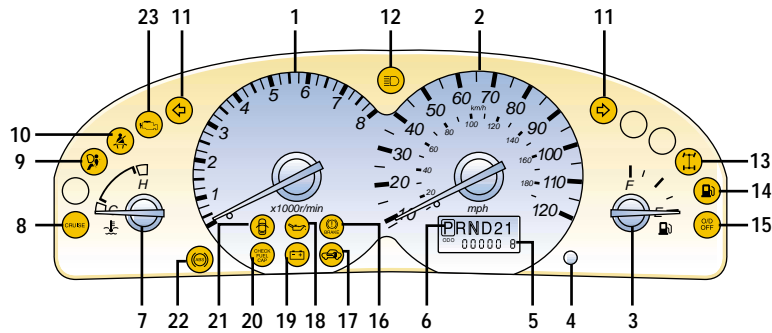

GAUGES

1. **Tachometer**
 2. **Speedometer**
 3. **Fuel gauge**
16-gallon/61-liter tank (2.0L and 3.0L)
 4. **Odometer/trip odometer selector**
Press to toggle between odometer and trip odometer
 5. **Odometer**
 6. **Gearshift indicator (A/T)***
 7. **Coolant temperature gauge**
If above normal range, stop vehicle and turn off engine, check coolant level when safe
- Tip:** Press and hold for more than 1 second to reset trip odometer

WARNING LIGHTS

8. **CRUISE** Cruise control on*
9. **Air bag readiness**
Front or side air bag malfunction, dealer inspection required
10. **Always fasten safety belts**
11. **Turn signals/hazard warning on**
12. **High beams on**
13. **4 wheel drive locked***, see Transmission
14. **Low fuel**
Refuel as soon as possible
15. **Overdrive off indicator***, see Transmission
16. **Brake system**
Parking brake on/low brake fluid
17. **Anti-theft on***
18. **Engine oil pressure warning light**
19. **Charging system warning light**
Dealer inspection required
20. **Check fuel cap**
Fuel filler cap not properly installed
21. **Door ajar**
22. **Anti-lock Brake System (ABS)***
ABS malfunction, normal brakes only, dealer inspection required
23. **Service engine soon**
Dealer inspection required

*Denotes optional equipment

Always check the Owner's Manual for more operating information and safety features

Instrument Cluster

Driver Controls

DRIVER CONTROLS

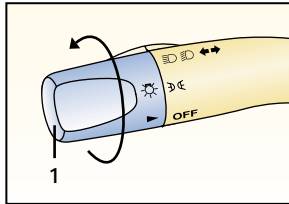

Turn signal/lighting control lever

OFF = Lights off

☞☞ = Tail, side marker, instrument, license plate and parking lights on: Rotate knob (1) to first notch

☞☞☞ = Tail, parking, instrument, license plate and head-lights on: Rotate knob (1) to second notch

High beams on/off: Push lever forward to detent/pull back to detent

To flash high beams: Pull lever back slightly and release

Turn signals right/left: Move lever up/down

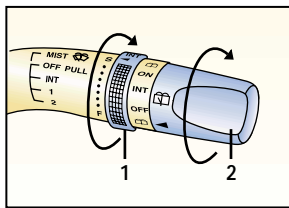

Wiper/washer control lever

Ignition switch must be in ACC or ON position

To activate interval wipers: Push lever down to first detent and rotate knob (1) to desired speed

To activate wiper normal or low speed: Push down to second detent

To activate high speed: Push lever down to third detent

To activate washer: Pull lever toward you

To activate mist: Push lever up and release

To activate rear interval wiper: Rotate knob (2) up to INT

To activate rear normal speed wipe: Rotate knob (2) up to ON

To activate rear wash: Rotate knob (2) to ☞☞☞ and release

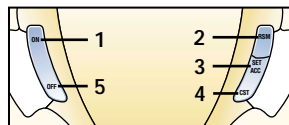

Cruise control*

Operates above 30 mph
Press and release ON (1)

To set speed: Press and release SET ACC (3) at desired speed; hold (3) to accelerate

To decelerate: Press and hold CST (4), release at desired speed; or tap brake pedal, press and release (3) at desired speed

Incremental deceleration: Press and release (4), each tap = minus 1 mph

Incremental acceleration: Press and release (3), each tap = plus 1 mph

To cancel: Tap brake/clutch* pedal or press OFF button (5)
Return to preset speed (after braking): Press and release RSM button (2)

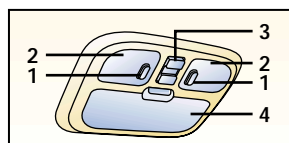

Overhead console*

1. Map/reading light switches

To turn on/off: Press switch

2. Map/reading light

To open: Press and hold rear of switch

To close: Press and hold front of switch

To tilt (panel closed): Press and hold front/rear of switch to open/close

4. Storage compartment*

To open: Press button, then pull to full open position

5. Garage door opener button/compartment*

See Owner's Manual for installation

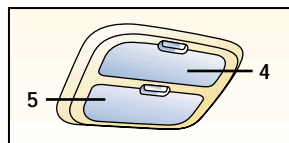

*Denotes optional equipment

Always check the Owner's Manual for more operating information and safety features

Overhead Console

Switches/
Locks

SWITCHES / LOCKS

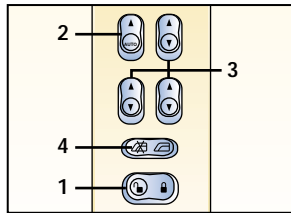

**Manual door locks
Lock button**

To lock: Press lock
To unlock front doors: Pull inside door handle

To unlock rear doors: Press unlock

Power door locks

1. Master front door lock switch

To lock/unlock all doors: Press / on driver's door switch

To lock doors without key:
With door open, press on driver's door switch, exit vehicle, close doors
Manual locks override power locks

Power windows

Operate with ignition in ON position

All windows may be controlled from driver's door; each passenger door has a separate switch

2. Driver's window

One-touch-down: Press rear of switch firmly and release, window goes down all the way; tap switch again to stop; press and hold for normal operation; press and hold front of switch to close

3. Passenger window switches

Press rear/front of switch to open/close

4. Power window lockout switch

Press right side of switch: only driver's switches control windows; press left side of switch and passenger controls function again

Tip: Power windows and moonroof can be operated for 10 minutes after key is off and with doors closed

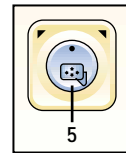

5. Dual power mirrors

To adjust left/right mirror: Rotate control switch left/right, tilt in direction of desired mirror movement

Tip: To lock mirrors in place, move control switch to center position

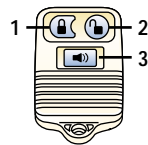

Remote keyless entry system*

Functions only with ignition in OFF position

1. Lock

Press button; pressing again within 3 seconds causes doors to relock, horn to beep

2. Unlock

Press to open driver's door; press again within 3 seconds to open other doors

3. Panic alarm

Press horn sounds; press again to stop, or turn ignition to ON or ACC position

Illuminated entry system*

Press UNLOCK or PANIC button on remote entry transmitter, interior lights come on; lights turn off after 30 seconds or with ignition in ON or ACC position

Liftgate

To lock/unlock: Press power door lock button or lock/unlock buttons on Remote Keyless Entry System

To open liftgate window: Pull up on right side handle

To open liftgate: Pull up on left side handle

WARNING: Cargo and load capacity limited by weight and distribution



Child-safety locks

Located at the edge of rear doors

To activate: Rotate knob to

To cancel: Rotate knob in opposite direction

WARNING: Since children may access either rear door, child-safety locks for both rear doors should be activated

*Denotes optional equipment

Always check the Owner's Manual for more operating information and safety features

Locks

Seats

SEATS

Front seat shoulder belt height adjustment

To raise/lower belt: Slide up/push release button (1) and slide down

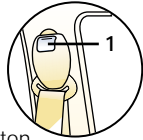

⚠ WARNING: Make sure adjuster locks in one of its positions

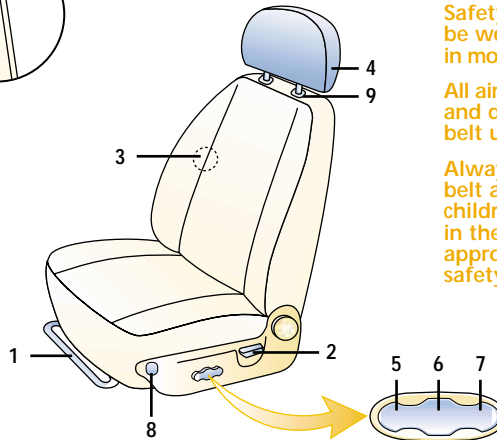

⚠ WARNINGS: Do not adjust seats while driving

Safety belts must always be worn when vehicle is in motion

All air bags are supplemental and do not replace safety belt usage

Always wear your safety belt and properly secure children 12 and under in the rear seat, and in appropriate child safety seats

Manual controls**1. Fore/aft adjustment**

Raise lever and hold, slide seat, release lever

2. Seatback angle/tilt slide seats

To adjust seatback: Lift and hold lever, lean forward or backward to tilt seat, release lever

To slide unoccupied seat: Lift lever to unlock, fold seatback down and slide seat forward

To lock seat: Move to desired position and raise seatback to upright position

3. Manual lumbar adjustment

Rotate clockwise/counterclockwise to increase/decrease firmness

4. Head restraint

To raise/lower: Pull up/hold release button (9) and push down

Power driver's seat***5. Raise/lower front of seat**

Pull/push front of switch up/down

6. Fore/aft adjustment

Slide entire switch horizontally

Raise/lower seat cushion

Pull/push entire switch vertically

7. Raise/lower rear of seat

Pull/push back of switch up/down

☀ Tip: Side-impact air bags* deploy from outboard side of driver and front passenger seatbacks

8. Heated seats*

Press to activate/deactivate

Folding rear seat, see Owner's Manual

*Denotes optional equipment

Always check the Owner's Manual for more operating information and safety features

Seats

Child-Safety Seats

CHILD - SAFETY SEATS

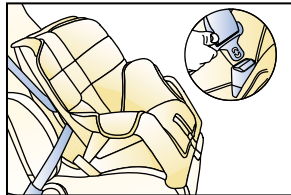

Child-safety seat
To install in rear outboard passenger seat positions using dual-locking mode retractor safety belts; see Owner's Manual for proper installation and seat tether and LATCH system instructions

⚠ WARNINGS: Use age appropriate child restraints, see Owner's Manual and state or province laws
Never place rear-facing infant-safety seat in front passenger seat in front of any air bag, an infant is in serious danger of being injured or killed
If you must install a forward-facing child-safety seat in the front seating position, move vehicle seat as far back as possible
It is strongly recommended that you install front facing child-safety seats in rear seating area

Rear child-safety seat anchors

Anchors located on rear seat cushion for securing child-safety seat (see Owner's Manual)

Dual locking mode lap/shoulder belt retractor

(front passenger and rear outboard belts only)

Emergency locking mode: Belt locks only on hard braking/cornering or impacts of about 5 mph or higher

Automatic locking mode must be used when installing child-safety seat

To activate: Pull webbing fully out of retractor until click is heard; belt will only tighten

To disengage: Unbuckle belt and allow webbing to retract fully; for complete details see Owner's Manual

1. Fan control

To increase speed and flow: Rotate knob clockwise

2. Air flow selections

- = air to dash
- = air to dash and floor
- OFF = system off, no air flow
- = air to floor
- = air to floor and windshield
- = defrost, air to windshield

3. Temperature selection

Cooler/warmer = rotate knob counterclockwise/clockwise

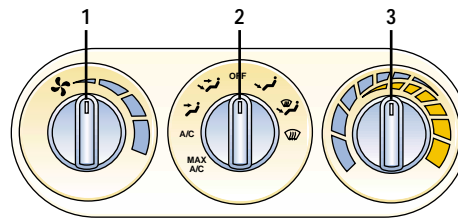

Air conditioning system

MAX A/C = cooling with inside air, air to dash only

A/C = cooling with outside air, air to dash only

Control positions for maximum defrost

Fan to maximum, temperature to maximum hot, air flow selector knob to

☀ Tips: To prevent moisture buildup, never drive with system off
To help prevent windshield fogging in humid weather, select DEF before starting engine

*Denotes optional equipment

Always check the Owner's Manual for more operating information and safety features

Climate Controls

Audio
Systems

RADIO/CASSETTE/COMPACT DISC

1. Power/Volume

Press to turn on/off; rotate to increase/decrease volume

2. Disc up ^ †

Press to skip forward to beginning of next CD

3. Disc down v †

Press to skip back to beginning of previous CD

4. Memory preset buttons

To set: Tune to station, press and hold until beep is heard

5. SEEK/TRACK/APC

Radio: Press ^ / v to automatically seek higher/lower frequency

CD: Press ^ / v to select next/previous track

Tape: Press ^ / v to automatically advance tape to beginning of next selection/replay selection; to stop this operation, press button again

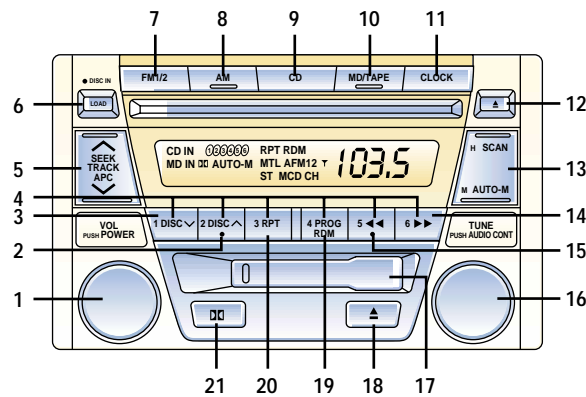

AM/FM/Cassette Tape/CD Player/Changer*

Tip: Clean cassette mechanism after 10-12 hours or less of use with Cassette Cleaning Cartridge

6. LOAD*

Single CD: Press button, WAIT will appear; when IN appears and CD door opens, load CD
Multiple CD: Press and hold LOAD until beep is heard; when IN is displayed load CD; when IN displays again load next CD

7. FM1/2

Press to select between FM1/FM2 station preset buttons (4)

8. AM

Press to select AM frequency band

9. CD: Press to play CD**10. MD*/Tape***

Press to play Mini-disc Player/cassette tape

11. Clock

To set: Press (11) and hold until beep is heard; press upper/lower portion of (13) to advance Hours/Minutes; press (11) again to set

12. CD eject button**13. Scan/Auto-Memory**

Press to briefly sample next listenable selections

Radio: Press and hold until a beep is heard; system automatically scans and temporarily stores six strong stations in each band; press again to cancel

14. Fast forward ►►

Press to fast forward through a track

15. Reverse ◀◀

Press to reverse through a track

16. Tuning/Audio Control

Tune: Rotate counterclockwise/clockwise for lower frequency/higher frequency
Audio control: Press to select BASS/MID/TREBLE/FADE/BALANCE; rotate right/left to adjust selected feature

17. Cassette door***18. Eject button***

19. Program Random†
Press to enable/cancel random play

20. Repeat

Press to replay current CD/tape selection

21. Dolby® Noise Reduction*

Reduces tape noise and hiss; press to activate/deactivate

* Denotes optional equipment

† For use with cassette tape player, MD player, or CD changer*

Always check the Owner's Manual for more operating information and safety features

Audio
Systems

Transmission

TRANSMISSION

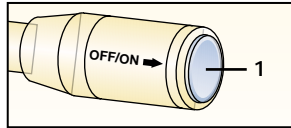
**Automatic transmission***

Gearshift must be in Park or Neutral to start engine; it must be in Park to remove ignition key

P = Park

To move gearshift from Park: You must press firmly on the brake pedal and the ignition must be in the ON position

R = Reverse

Never engage Reverse when vehicle is moving

N = Neutral

No gear is engaged; vehicle can roll freely, even on a slight incline, unless the brakes are applied

D (Overdrive)

For normal driving; Transmission shifts through four forward gears

Tip: Torque converter lock-up improves fuel economy and can feel like an additional gear

D (Overdrive Off)

Press the overdrive switch (1) to disengage overdrive; an indicator light on the instrument panel will illuminate

2 = Second

Place the gearshift lever in second when accelerating on slippery roads or to provide additional engine braking on downgrades

1 = First

Provides maximum engine braking on steep downgrades

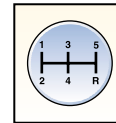
**Manual transmission**

Depress clutch pedal completely to start engine and change gears

Stop vehicle completely before shifting into reverse

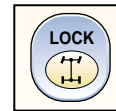
**4X4 system*†**

AUTO = Four-wheel drive
Power at normal speed to front axles

at all times and to rear axles as required for traction, 4X4 light off

LOCK = Full time power to front/rear axles, 4X4 light on

To shift from 4X4 AUTO to 4X4 LOCK (any forward speed): Press switch

To shift from 4X4 LOCK to 4X4 AUTO high (any forward speed): Press switch

Break-in period

First 1,000 miles: Avoid heavy repeated brake use; avoid full throttle, rapid acceleration or kick-down of transmission; drive at varying road and engine speeds

Do not tow a trailer for first 500 miles

Do not use special break-in oils

Tip: Follow the same procedures with newly overhauled engine or when brakes are replaced

Anti-lock Braking System (ABS)*

ABS automatically reduces hydraulic pressure to any wheel on the verge of locking up
You may feel a slight pulsing of the brake pedal and hear a clicking noise; this tells you the

ABS is functioning properly; increase pressure on pedal for maximum braking

Tip: Maintain constant pressure on the brake pedal
Do not pump the brakes

Tire economy and tips

Check pressure monthly when tires are cold

See Owner's Manual for rotation schedule and chart

Tire pressure

Decal on driver's door latch pillar provides tire size and pressure information

Tire chains*†

Tire chains can damage aluminum wheels; use on steel wheels only

Tip: Use only SAE class "S" chains, install only on front axles (with P235/70R16 tires)
SAE class "S" chains can be installed on both front and rear wheels (with P215/70R16 tires); install as tightly as possible and retighten periodically
Never exceed 30 mph with tire chains

Spare tire

Stored under cargo area cover

Jack handle

Stored underneath cargo cover

*Denotes optional equipment

† See Owner's Manual

Always check the Owner's Manual for more operating information and safety features

Driving Tips

Under Hood

UNDER HOOD

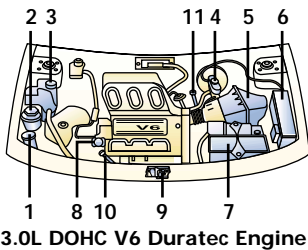
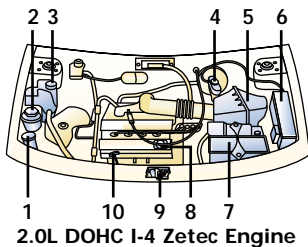

- 1. Windshield washer reservoir**
Fill with windshield washer fluid, not water
- 2. Power steering fluid reservoir,** Check with engine off and at normal temperature; fluid level should be within MIN and MAX lines
- 3. Engine coolant reservoir**
Level should be at cold fill level or within the cold fill range when cold
⚠ WARNING: Never remove coolant reserve tank cap while engine is running or hot; you could get burned
- 4. Brake/clutch fluid reservoir**
Fill to MAX mark with DOT 3 fluid, check with cap on
- 5. Air filter**
- 6. Power distribution box**
- 7. Battery**
- 8. Engine oil filler cap**
- 9. Hood latch**
- 10. Engine oil dipstick**
Check with engine off and at normal temperature; oil level should be within crosshatched area of dipstick
- 11. Automatic transmission fluid dipstick****
Check with engine on at operating temperature; fluid level should be within crosshatched area

NORMAL SERVICE INTERVALS

5,000 miles*	A
7,500 miles	A
15,000 miles	A
22,500 miles	A
30,000 miles	A B
37,500 miles	A
45,000 miles	A F
52,500 miles	A
60,000 miles	A B C E
67,500 miles	A
75,000 miles	A
82,500 miles	A
90,000 miles	A B D
97,500 miles	A
100,000 miles	G

Rotate tires every 7,500 miles or sooner if needed

- A.** Change: Engine oil/replace oil filter
Lubricate: All locks and hinges
- B.** Inspect: Drive belts, fuel lines and hoses, brake lines and hoses, disc and drum brakes, steering operation and linkages, front and rear suspension ball joints, driveshaft dust boots, chassis and body bolts, exhaust system heat shields, cooling system, refrigerant amount
Replace: Air filter, fuel filter
- C.** Inspect: Engine valve clearance (2.0L), hoses and tubes for emission system
- D.** Replace: Engine timing belt (2.0L)[†]
- E.** Replace: PCV valve (2.0L)[†]
- F.** Replace: Green coolant[†]

- G.** Replace: PCV valve (3.0L)[†], spark plugs (platinum-tipped type), yellow coolant[†], rear differential oil (for 4WD)

Tip: For additional service details, see Owner's Manual

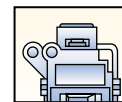

Fuel pump shutoff

Disables fuel pump after a substantial jolt; located on right side of passenger compartment behind A-pillar lower trim panel (below dash)

To reset: Press down top of exposed red reset button

⚠ WARNING: Do not reset shutoff switch if you see or smell fuel

* Special operating conditions
** Denotes optional equipment
[†] See Owner's Manual

Always check the Owner's Manual for more operating information and safety features