

## DRIVER ASSURANCE

**Mazda Drivers Assurance Plan**  
Check out [www.mymazda.com](http://www.mymazda.com), the website dedicated to you. Manage your maintenance records, receive valuable offers, see the latest accessories and much more!

**Mazda Roadside Assistance**  
Exhilaration, liberation and inspiration are great reasons to drive a Mazda car, truck, SUV or minivan. In addition to all the other great standard features, you also get peace of mind, our Emergency Roadside Assistance Plan, it's just a phone call away, 24 hours a day, 365 days a year, call **1-800-866-1998**

**Mazda "bumper-to-bumper" Limited Warranty**  
We design and build every Mazda to give you driving pleasure now and far down the road. We're so confident in our quality that we cover the entire vehicle against defects in materials and workmanship

for 48 months or 50,000 miles, whichever comes first

**Mazda Service Transportation Solution**  
Being without your Mazda may put a crimp in your day, if you do ever have to take your Mazda in for repairs don't worry, you're covered. With the Mazda Transportation Solution, you will be given a loaner car at no charge when your Mazda vehicle is in for warranty repairs. For all the details, see your Mazda Dealer

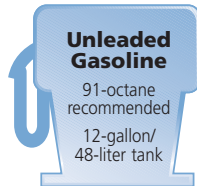

This Quick Tips® guide is provided by Mazda North American Operations to make your Mazda ownership experience more convenient. It is not intended to replace your Owner's Manual.

If you have any questions about your vehicle, you are invited to contact your local dealer. Or if you need additional help, feel free to call our

**Customer Assistance Center at 1-800-222-5500**

Monday through Friday,  
8 a.m.-4:45 p.m., Pacific  
9 a.m.-5:45 p.m., Eastern/Central



©2005 Calcar. Quick Tips® is a trademark of Calcar, made in USA 4/05 25.889M DOT Mazda North American Operations reserves the right to change product specifications at any time without incurring obligations. 9999-95-031C-06QT

## MAZDA MX-5 MIATA

### Quick Tips®



Reference  
Guide for  
Controls and  
Functions

2006

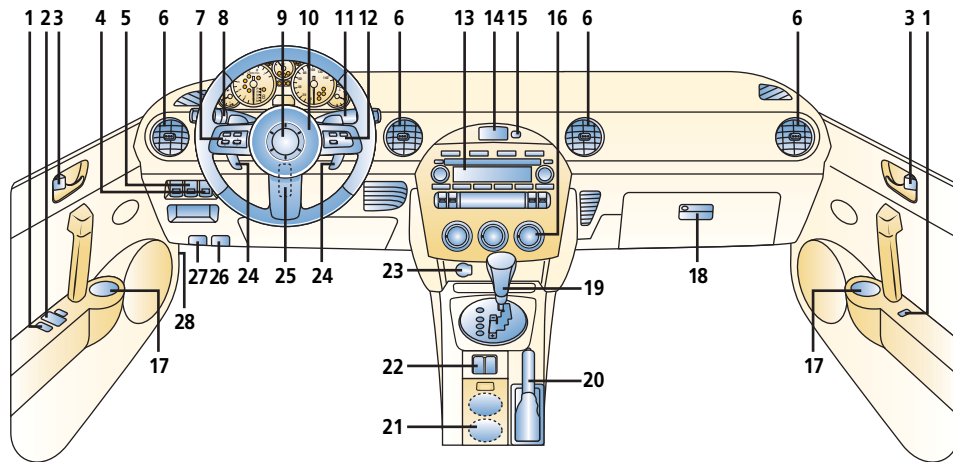

## DRIVER'S VIEW



- 1. Power door locks\***, see Locks
- 2. Power outside mirror switch**, see Switches/Interior Lights
- 3. Manual door locks**, see Locks
- 4. Passenger air bag deactivation switch**, see Getting Started
- 5. DSC Traction Control System\***, see Instrument Cluster
- 6. Air vents**  
Move vents to direct airflow
- 7. Audio control switches\***, see Getting Started
- 8. Turn signal/lighting control lever**, see Getting Started
- 9. Horn**  
Press for horn
- 10. Air bag**
- 11. Wiper/washer lever**, see Getting Started
- 12. Cruise control\***, see Getting Started
- 13. Audio system**, see Audio Systems
- 14.  Hazard warning switch**  
Press on/off
- 15. Passenger air bag off indicator**, see Getting Started
- 16. Climate control system**, see Climate Controls
- 17. Bottle holder**  
**CAUTION: Use plastic bottles with caps, cups may spill when door is closed**
- 18. Glove compartment**
- 19. Gearshift lever**, see Transmission
- 20. Parking-brake lever**
- 21. Cup holders**
- 22. Power window switches**, see Switches/Interior Lights
- 23. Accessory socket**
- 24. Steering paddle switches (A/T only)\***, see Transmission
- 25. Tilt steering-wheel lever**, see Getting Started
- 26.  Hood release handle**  
Pull to open partially
- 27.  Remote trunk-lid release**  
Press button to open trunk
- 28. Fuse panel**

\*Denotes optional equipment

Always check the Owner's Manual for more operating information and safety features

Driver's  
View

## GETTING STARTED

**Getting Started**

Mazda MX-5 Miata Quick Tips® are designed to quickly familiarize you with some important features of your Mazda MX-5 Miata

The Driver's View tab is your index to the Quick Tips®, locate the item you would like to learn more about and then turn to the listed tab

This Getting Started section contains important operating tips about your Mazda MX-5 Miata

Items identified in blue text call out important information

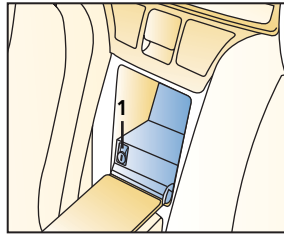
**Remote fuel filler release lever**

Located in rear compartment between seats

Pull remote fuel-filler lid release lever (1) to open fuel-filler lid

**Behind seat storage**

Move seatbacks forward to access additional storage compartments, see Seats

**Tire Pressure Monitoring System (TPMS)\***

Warning light illuminates on instrument cluster for a few seconds with ignition on

If tire pressure is low, warning light illuminates with audible beep sound, adjust tire pressure to correct specifications, perform tire pressure adjustment before driving, a digital tire pressure gauge is recommended

Flashing warning light may indicate malfunction, dealer inspection required

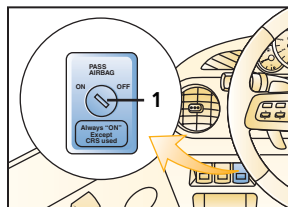
**Passenger's seat air bag deactivation switch†**

Deactivate passenger's seat air bag when using a child-safety seat

To deactivate/activate: Insert ignition key or auxiliary key (Advanced keyless entry\*) in switch (1), rotate to OFF/ON, remove key

Passenger air bag off indicator illuminates when air bag is deactivated and ignition is on

**⚠ WARNINGS:** When using a rear-facing infant-safety seat always set the passenger seat air bag deactivation switch to OFF position  
An infant is in serious danger of being injured or killed if front passenger air bag is deployed if you must install a forward-facing child-safety seat in the front seating position, move vehicle seat as far back as possible and set air bag deactivation switch to OFF position

**Passenger air bag deactivation indicator light**

Front air bag deactivation indicator light provides current status of front passenger air bag and pretensioner system

If total seated weight on front passenger seat is less than approximately 66 lb., front passenger air bag deactivation indicator light illuminates, air bag/pretensioner will not deploy/activate in an accident

If the total seated weight is greater than approximately 93 lb., light does not illuminate, and the air bag/pretensioner will deploy/activate in an appropriate accident, see Owner's Manual

\*Denotes optional equipment

†For other rare circumstances when passenger air bag can be shut off, refer to NHTSA guidelines

Always check the Owner's Manual for more operating information and safety features

## GETTING STARTED

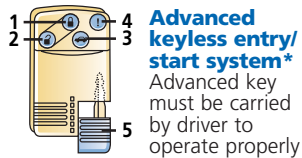

**Advanced keyless entry/start system\***  
Advanced key must be carried by driver to operate properly

Refer to Owner's Manual for additional instructions

### Advanced keyless system customization

Your authorized Mazda Dealer can customize your system if desired with features such as auto-lock: After exiting the vehicle after driving, the car will automatically lock. For additional information on customizable features, see Owner's Manual

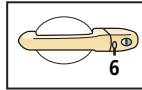

### Locking doors

Driver's/passenger's door request switch: Press (6) once on either door to lock both doors

Advanced key transmitter: Press button (1); pressing again within a few seconds causes doors to relock and horn to beep

### Unlocking doors/opening trunk

Driver's door request switch: Press (6) to unlock driver's door; press again within 3 seconds to unlock both doors

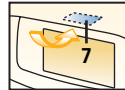

Passenger's door request switch: Press (6) on passenger's door; both doors unlock simultaneously

Trunk request switch: Press (7) on trunk lid, only trunk will open, doors do not lock/unlock

Advanced key transmitter: Press button (2) for driver's door; press again within a 3 seconds to unlock passenger's door

**Press and hold button (3) for more than 1 second** to open trunk

### Activating panic alarm

Panic alarm: Press and hold button (4) for more than 1 second; horn sounds, hazard warning lights flash; to stop, press any remote button

\*Denotes optional equipment

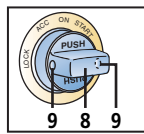

### Starting engine

Press start knob (8); when KEY indicator (green) illuminates on instrument

cluster; turn start knob (8) to START position to start engine

**Tip: Engine will not start if trunk is open and advanced key is placed in trunk**

### Auxiliary key operation

If advanced key cannot be used due to a malfunction or dead battery, use auxiliary key (5) to lock/unlock doors, trunk and to start vehicle

To start vehicle: Remove start knob cover (8) by pressing both side release buttons (9) while pulling; insert auxiliary key into key cylinder and turn to start engine

**Tip: Do not place advanced key on or around dashboard, storage**

**compartments such as glove box or in open trunk, engine may not start or warnings may activate**

### Turning off engine

Turn start knob to ACC position to turn engine off, push in and turn start knob to LOCK position

**Tip: Vehicle battery may be discharged if start knob is left in ACC position**

Always put vehicle in Park (P), set parking brake and turn start knob to LOCK position when exiting vehicle

### System operation warnings

KEY indicator light flashes (green) indicates advanced key transmitter battery power is low

KEY indicator light illuminated continuously (red) indicates system malfunction, and auxiliary key should be used, have vehicle inspected at an Authorized Mazda Dealer as soon as possible

**Tip: When using advanced keyless system, system will beep as confirmation of lock/unlock requests, system will also beep if start knob is left in ACC position, advanced key has been left in vehicle or if advanced key is removed from vehicle while vehicle is running**

For additional system operation warnings, see Owner's Manual

### Replacing battery

See Owner's Manual for complete instructions

### Cautions on use

To avoid damage to advanced key, DO NOT SUBJECT to severe impacts, liquids or place heavy objects on advanced key or leaving advanced key exposed to direct sunlight or high temperatures

See Owner's Manual for all cautions and warnings

Always check the Owner's Manual for more operating information and safety features

GETTING STARTED

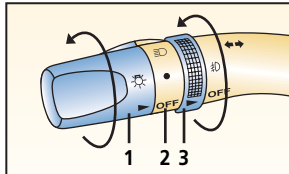

**Turn signal/lighting control lever**

**OFF** = Lights off

● = Tail, parking and dashboard lights on: Rotate knob (1) to first notch

☰ = Tail, parking, dashboard and headlights on; rotate knob (1) to second notch

High beams on/off: Push lever (2) forward/pull lever back to original position

To flash high beams: Pull back lever (2) slightly and release  
Turn signals right/left: move lever up/down

☼ = Fog lights\* on: Rotate (3); functions only with headlight low beams on

**Tip: Headlights will turn off, parking lights remain on, if lights are left on and switch is in lock position or key removed**

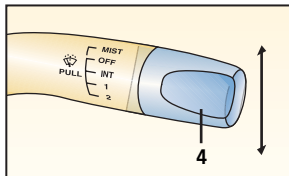

**Windshield wiper/washer lever**

Intermittent wiper: One click down

Normal wiper speed: Two clicks down

Fast wiper speed: Three clicks down

Single wipe: Push lever up

Wash and wipe: Pull lever (4) toward you and hold; washer and wipers will be activated until lever is released

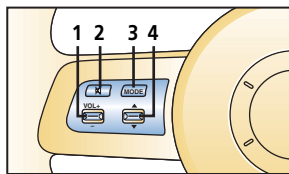

**Steering-wheel audio controls\***

To increase/decrease volume: Press up/press down switch (1)

Press (2) to mute

Press (3) to select AM, FM1, FM2, CD, SIRIUS\* radio mode

Press up/press down (4) to seek next/previous preset radio station/CD track

Press and hold up/down (4) to seek radio stations in AM, FM1, FM2

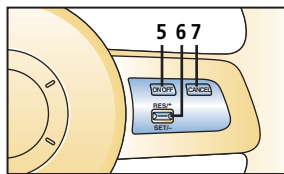

**Cruise control\***

Operates above 19 mph

Press ON/OFF switch (5) to enable/disable

To set speed: Press switch (6) down and release

To increase set speed: Press switch (6) up and release at desired speed

To decrease set speed: Press switch (6) down and release at desired speed

To cancel: Tap brake or clutch pedal (manual transmission) or press CANCEL switch (7)

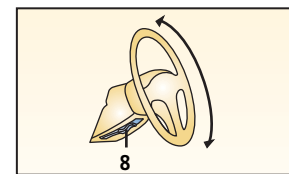

**Tilt steering-wheel lever**

Pull lever (8) down to unlock column, adjust angle of column

**WARNING: Do not adjust steering-wheel while driving**

\*Denotes optional equipment

Always check the Owner's Manual for more operating information and safety features

## Instrument Cluster

### INSTRUMENT CLUSTER





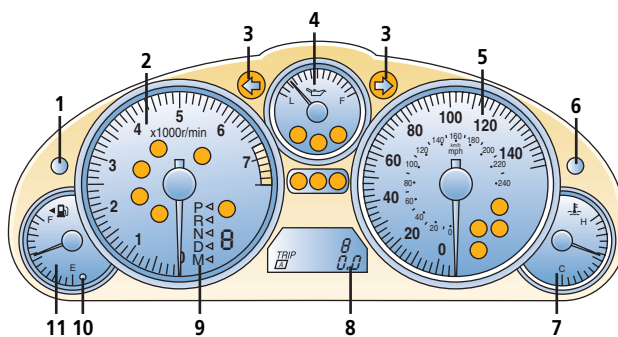









#### GAUGES AND CONTROLS

1. **Dashboard illumination control**, Rotate to dim/brighten
  2. **Tachometer**  
Avoid red zone
  3. **Turn signal/hazard warning on**
  4. **Engine oil pressure gauge**  
If outside normal range, stop vehicle safely and turn off engine, check oil level  
See Owner's Manual for scheduled maintenance
-  **Tip: Needle fluctuates with engine RPM, this is normal**
5. **Speedometer**
  6. **Odometer/trip odometer selector**  
Press to select odometer or trip odometer A/B; press and hold to reset selected trip odometer



7. **Coolant temperature gauge**  
If above normal range, stop vehicle safely and turn off engine; check coolant level when safe
8. **Odometer/trip odometer display**
9. **Shift/gear position indicators\***
10. **Low fuel indicator**
11. **Fuel gauge**  
12-gallon/48-liter tank

#### WARNING LIGHTS

-  **CRUISE Cruise control\* on**  
Amber light: Cruise control system activated  
Green light: Cruising speed set; see Getting Started
-  **High beams on**, see Getting Started
-  **Immobilizer system on**, see Locks
-  **Check engine**  
Dealer inspection required
-  **Air bag readiness**  
If light flashes or stays on, the air bags may not operate in an accident; dealer inspection required
-  **Brake system**  
Parking brake on/low brake fluid
-  **AT Automatic transmission warning light\***
-  **Charging system**  
Possible alternator or charging system malfunction, dealer inspection required
-  **Anti-lock Brake System (ABS)\***  
Indicates ABS malfunction, dealer inspection required
-  **Door ajar**
-  **DSC OFF Dynamic Stability Control\* off**
-  **Tire pressure monitoring system\***, see Getting Started
-  **Always fasten seat belts**
-  **FLAT TIRE Flat tire warning light\***  
Flat tire or system malfunction, dealer inspection required
- **KEY\***, see Getting Started
-  **TCS/DSC indicator light\***  
Flashes when traction control or stability control is functioning, steady light indicates malfunction  
Enhances traction and safety by regulating engine and brake torque  
TCS/DSC light may occasionally flash while driving, this indicates that the TCS/DSC was performing a correction to help maintain your best vehicle control, if TCS/DSC light remains on, see your Mazda Dealer

\*Denotes optional equipment

Always check the Owner's Manual for more operating information and safety features

Instrument Cluster

## Locks

### LOCKS

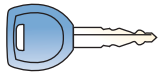

#### Key

Operates ignition and all locks

 **Tip: Use key number plate to purchase a new key; store in a safe place separate from vehicle**

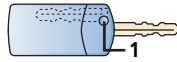

#### Retractable key\*

To fold/unfold: Press release button (1)

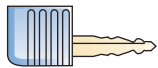

#### Auxiliary key\*

See Getting Started

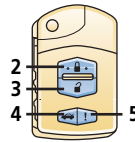

#### Remote keyless entry system\*

Functions only with ignition in OFF position

To lock doors: Press  button (2); pressing again within a few seconds causes doors to relock and horn to beep

To unlock: Press  button (3) for driver's door; press again within 3 seconds to unlock passenger's door

**Press and hold  button (4) for more than 1 second** to open trunk

Panic alarm: Press and hold  button (5) for more than 1 second; horn sounds, hazard warning lights flash; to stop, press any remote button



#### Advanced keyless entry/start system/auxiliary key\*

See Getting Started

#### Immobilizer system

Prevents engine from running unless coded key is used, see Owner's Manual

 **WARNING: Never leave children unattended with key in vehicle**

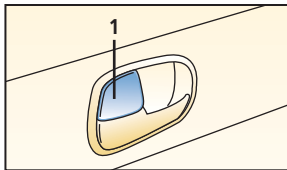

#### Manual door locks

To lock/unlock: Push button (1) into handle/pull toward you

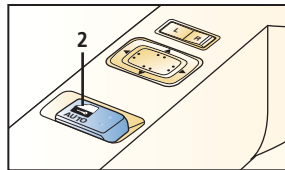

#### Power door locks\*

Both doors can be locked/unlocked using power door lock switch (2) or by using key in driver's door

To unlock driver's door: Turn key toward the front of vehicle

To unlock both doors: Turn key and hold in unlock position for more than 1 second

To lock both doors: Turn key toward the back of vehicle

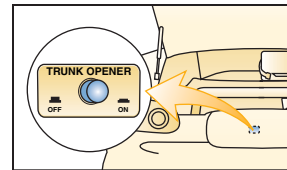

#### Remote trunk-lid release lock-out

Switch in ON position, remote trunk release functions normal; OFF position disables system; switch located in trunk, see Trunk

\*Denotes optional equipment

Always check the Owner's Manual for more operating information and safety features

Locks

Switches/  
Interior Lights

SWITCHES / INTERIOR LIGHTS

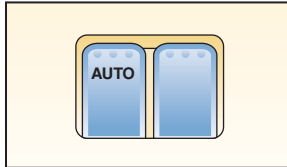

**Power windows**

Operate only with ignition on  
To open/close: Push down/pull up front of switch  
Press driver window button down completely once for one touch auto down

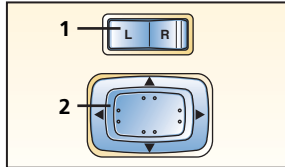

**Dual power mirrors**

Operates in accessory mode or with ignition on  
To adjust left/right mirror: Push selector switch (1) left/right, press switch (2) in direction of desired movement

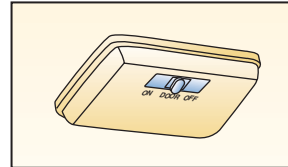

**Dome light**

ON = Light always on  
OFF = Light always off  
DOOR = Light on when a door is open

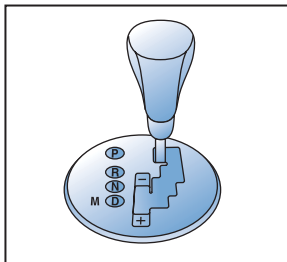

**Automatic transmission\***

**P = Park**  
To move gearshift from Park: Press firmly on brake pedal, then move gearshift to gear selection  
**R = Reverse**  
**N = Neutral** No gear engaged  
**D (Overdrive)**  
For normal driving: Shifts through all forward gears automatically



**M (Sport A/T manual shift mode)\***

Move shifter from D to M to engage manual shift mode, M will be illuminated on shift position

indicator located in the instrument panel  
Manual shifting of transmission is achieved by moving shifter back to upshift and forward to downshift, move shifter from M to D to engage automatic shift mode

**Tip:** You can also shift using steering wheel controls  
**To upshift:** Tap either up switch toward you  
**To downshift:** Tap either down switch away from you

\*Denotes optional equipment

**Gear indicator (A/T only)\***

Illuminated numeral of gear indicator located in the instrument panel displays current gear in Automatic and Manual shift modes

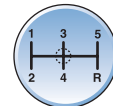

5-speed

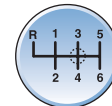

6-speed\*

**Manual transmission**

Depress clutch pedal to start engine and change gears

**Tip:** Do not shift into 1st above 20 mph or clutch failure could occur  
Resting your foot on the clutch pedal while driving and using the clutch to hold your vehicle at a standstill while waiting on a hill may reduce clutch life

Always check the Owner's Manual for more operating information and safety features

Transmission



## SEATS

**Manual controls****1. Fore-aft adjustment**

Lift lever and hold, slide seat, release lever

**2. Safety belt buckle****3. Seatback angle**

To adjust: Lift and hold lever, lean forward or backward, release lever

 **Tip: Move seatbacks forward to access additional storage compartments**

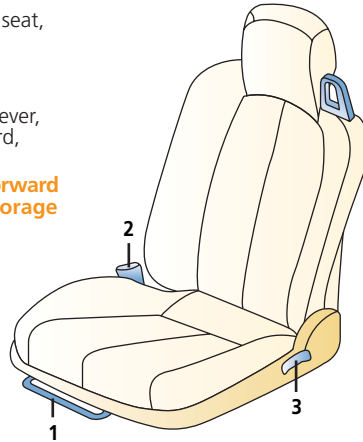

 **Tip: Side-impact air bags deploy from outboard side of driver and front passenger seatbacks**

 **WARNINGS: Do not adjust seats while driving**

**Safety belts must always be worn when vehicle is in motion**

**All air bags are supplemental and do not replace safety belt usage**

**Always wear your safety belt and properly secure children and set passenger side air bag deactivation switch to OFF position**

**Safety belt emergency locking mode**

Belts lock only on hard acceleration, braking, cornering or impacts of about 5 mph or more

**Automatic locking mode (front passenger safety belt only)**

Must be used when installing child-safety seat

To activate: Pull belt fully out of retractor, allow belt to retract until click is heard; belt will only tighten

To disengage: Unbuckle belt and allow belt to retract fully

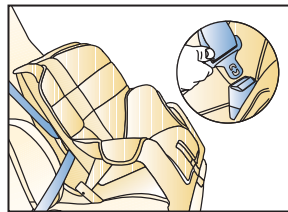
**Child-safety seat**

To install in passenger seat: Move seat as far back as possible; use dual locking mode retractor safety belt; see Owner's Manual for proper installation of child seat and LATCH system instructions

 **WARNING: Use age appropriate child restraints, see Owner's Manual and state or province laws**

 **WARNINGS: When using a rear-facing infant-safety seat always set the passenger seat air bag deactivation switch to OFF position**

**An infant is in serious danger of being injured or killed if front passenger air bag is deployed**

**If you must install a forward-facing child-safety seat in the front seating position, move vehicle seat as far back as possible and set air bag deactivation switch to OFF position**

*Always check the Owner's Manual for more operating information and safety features*

CLIMATE CONTROLS

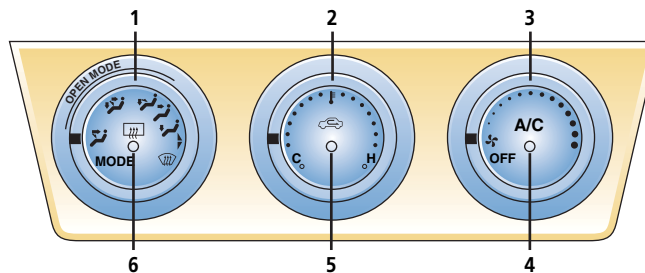

**1. Airflow selector**

- = air to dash/waist, open mode
- = air to dash/waist/floor, open mode
- = air to waist/floor, open mode
- = air to dash
- = air to floor
- = air to windshield and floor  
A/C compressor is on
- = defrost, air to windshield  
A/C compressor is on

**Tip:** Select **OPEN MODE** position when lowering convertible top for best comfort

**WARNING:** When using position always set temperature control to hot or warm to prevent glass fogging

**2. Temperature control**

Rotate knob counterclockwise/clockwise for cooler/warmer

**3. Fan control**

Rotate knob counterclockwise/clockwise to decrease/increase fan speed, turn to OFF to shut system off

**4. A/C Air conditioning\***

Press to turn on/off

**Tip:** Use A/C to dehumidify air

**5. Air intake control**  
Press to select fresh air (indicator light off)/recirculated air (indicator light on)

**WARNING:** Do not use recirculated air mode in cold or wet weather; windows could fog and hamper vision

**6. Rear window defogger**

Press to activate/deactivate

**Control positions for maximum defrost**

Fan to maximum, temperature to maximum hot, airflow selector knob to

**Tips:** When selected, air is dried by A/C compressor operation when outside temperature is above 39°F

To help prevent windshield fogging in humid weather, select

To prevent moisture buildup, never drive with system off with convertible top up

\*Denotes optional equipment

Always check the Owner's Manual for more operating information and safety features

## Audio Systems

### AM / FM STEREO / CD / MP3

#### 1. Power/Volume

Press to turn on/off; rotate to increase/decrease volume

#### 2. LOAD

CD: When LOAD button is pressed, CD will load and play even if CD eject button has been previously pressed

CD changer\*: To load multiple discs: Press and hold LOAD (2) until beep sound is heard; insert CD when "In" is displayed

To eject disc: Press Eject (8)

To eject specific disc: Press and hold Eject (8) until beep sound is heard; within five seconds press the desired tray number 1-6 (10)

#### 3. FM/AM

Press to turn radio on and select between FM1/FM2/AM station preset buttons (10)

#### 4. CD slot

5. SAT\*, Satellite ready capability

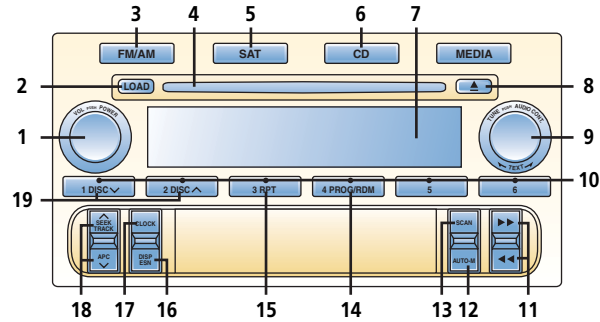

**Tip:** Insert single CD into slot, auto-loading function will set CD and begin play without pressing LOAD button

#### 6. CD

Press to play CD

#### 7. Display

#### 8. CD eject button

#### 9. Tune/Audio/Text Control

Radio: Rotate counter-clockwise/clockwise for lower/higher frequency

Audio: Press to select ALC or AudioPLT\*/BASS/TREB/FADE/BAL/BEEP

Rotate right/left to adjust selected feature

Text\*(MP3): Rotate right/left to display titles

**Tip:** Automatic Level Control (ALC) automatically adjusts audio volume depending on vehicle speed

#### 10. Memory preset buttons

To set: Tune to station, press and hold until beep sound is heard

#### 11. Reverse◀◀ /Fast forward ▶▶

Press to reverse/fast forward through a track

#### 12. Auto-Memory

Press and hold until a beep sound is heard; system automatically scans and temporarily stores six strong stations in each band; press again to switch to another preset station

#### 13. Scan

Radio: Press to sample strong stations, press again to stop at current station

CD/MP3: Press to play first few seconds of each selection, press again to stop at current selection

#### 14. Random\*

Press to play CD/MP3 selections in random order

#### 15. RPT

Press to replay current CD/MP3 selection

#### 16. DISP

CD/MP3: Press repeatedly to scroll through displays

#### 17. Clock

To set: With ignition in ACC or ON position, press top of switch (17) until beeper sounds and time flashes; press top of switch (18) to set hour, press bottom of switch (18) to set minutes, press top of switch (17) to start clock

#### 18. SEEK/TRACK/APC

Radio: Press ▲ / ▼ to automatically seek higher/lower frequency  
CD/MP3: Press ▲ / ▼ to select next track/beginning of current track

#### 19. Disc ^ / v \*

Press to skip to next/previous CD

\*Denotes optional equipment

Always check the Owner's Manual for more operating information and safety features

Audio Systems

Convertible

CONVERTIBLE

**Convertible top operation**

**Tip:** Always lower side windows before lowering or raising convertible top

To lower: Stop vehicle in a safe place and park on a level surface; set parking brake; lower side windows; remove items from rear storage area; push unlock button (1) while pulling top latch (2) rearward, continue to pull top latch back completely; pull front of top rearward to release from windshield header

If lowering top from inside vehicle, use either handle (3) to lower

If lowering top from outside vehicle, grasp side of top, near windshield header (4) to lower

Fold back top and press firmly on front of top to securely lock in lowered position

Raise wind blocker (6) if desired

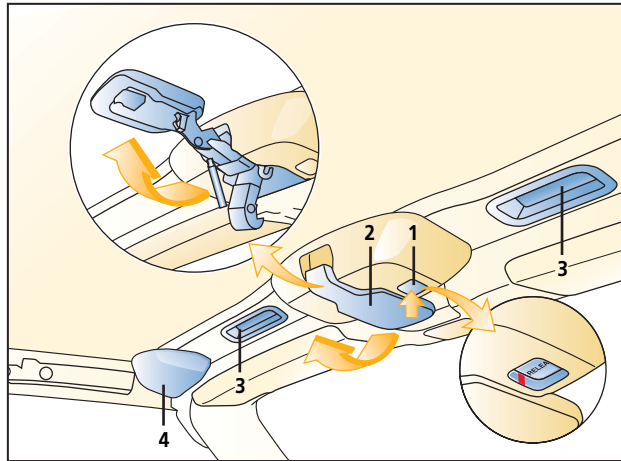

**Tip:** If top is hard to lower; raise top slightly; then slowly lower it while pressing upper part of rear glass with your hand

To raise: Stop vehicle in a safe place and park on a level surface; set parking brake; lower side windows; lower wind blocker (6); pull unlock lever (5) to release top from lowered position

If raising top from inside vehicle, grasp either handle (3) to raise

If raising top from outside vehicle, grasp side of top near windshield header (4) to raise

Push lever on top latch up until lock button (1) clicks and top latch is securely locked

**WARNING:** If red indicator is visible on unlock button (1), top is not securely latched

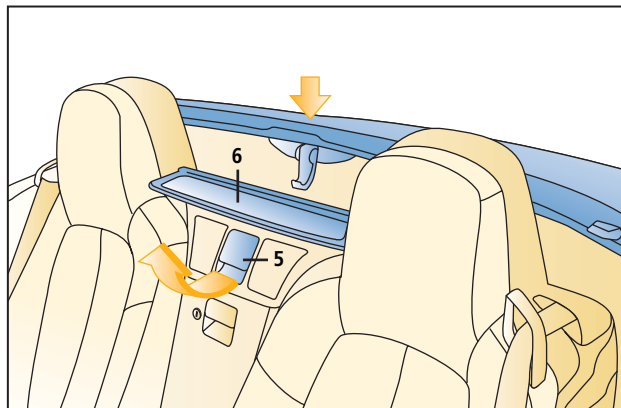

Always check the Owner's Manual for more operating information and safety features

Convertible

## Trunk

### TRUNK

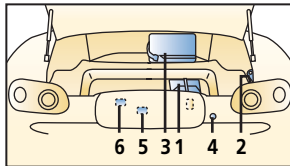

#### Trunk

##### 1. Tool bag

Contains lug wrench, tow hooks and jack handle

##### 2. Jack

To remove: Turn knob counterclockwise, open cover, turn wing bolt counterclockwise, remove jack

##### 3. Instant Mobility System emergency flat tire repair kit (IMS)\*

Your Mazda MX-5 Miata is not equipped with a spare tire, if tire repair is required, repair tire with emergency flat tire repair kit, see Owner's Manual for instructions

If equipped with optional run-flat tire, see Owner's Manual

##### 4. Lock

To lock/unlock: Insert key and turn counterclockwise/clockwise

##### 5. Remote trunk-lid release lock-out, see Locks

##### 6. Trunk light

 **Tip: Trunk can be opened using remote keyless entry system**

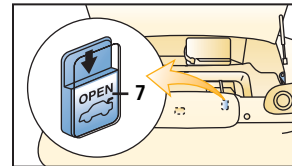

##### 7. Trunk release lever

Allows you to escape should you become locked in trunk

To open: Slide lever in direction of arrow, lever will glow if it has been exposed to light

#### Tire economy and tips

Check pressure at least monthly when tires are cold

Maintain correct 4-wheel alignment and tire balance; rotate tires at 7,500-mile intervals; see Owner's Manual for rotation chart

#### Tire pressure

Decal on the edge of the driver's door jamb provides tire pressure information

#### Tire chains\*†

Tire chains can damage aluminum wheels; use on steel wheels only

 **Tips: Use only genuine Mazda tire chains; install only on rear tires; install as tightly as possible and retighten periodically**  
**Never exceed 30 mph with tire chains**

#### Anti-lock Brake System (ABS)\*

ABS automatically reduces hydraulic pressure to any wheel on the verge of locking up

You may feel a slight pulsing of the brake pedal and hear a clicking noise; this tells you the ABS is functioning properly; increase pressure on pedal for maximum braking

 **Tips: Maintain constant pressure on the brake pedal**  
**Do not pump the brakes**

#### ABS self test

A self-diagnostic test is performed when vehicle starts to move; you may feel some brake pedal pulsation and hear some noise, this is normal

#### Gas cap

After filling vehicle with gasoline, fully reinstall gas cap by turning clockwise until a clicking sound is heard, if gas cap is not fully installed, Check Engine light may come on

For more information on Check Engine light, see Owner's Manual

\*Denotes optional equipment

† See Owner's Manual

Always check the Owner's Manual for more operating information and safety features

#### Driving Tips

Under Hood

UNDER HOOD

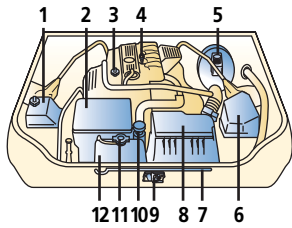

2.0-liter 4-cylinder

**Tip:** Check all fluids with vehicle parked on a level surface

**1. Windshield washer fluid reservoir**

Refill with windshield washer fluid

**2. Battery**

**3. Engine oil filler cap, SAE 5W-20**

**4. Engine oil dipstick**

Check with engine off and at operating temperature. Engine oil should be between FULL and LOW marks on dipstick.

**5. Brake/clutch\* fluid reservoir**

If brake/clutch\* fluid level is low, have your vehicle inspected by your nearest Mazda dealer.

**6. Fuse block**

**7. Hood support rod**

**8. Air filter**

**9. Hood latch**

Push to right to release hood

**10. Power steering fluid reservoir**

Check with engine off and at operating temperature. Level should be between MIN and MAX.

**11. Cooling system cap**

Do not remove if engine is running or hot.

**12. Engine coolant reservoir**

Check when engine is cold; fluid level should be between the FULL and LOW marks on reservoir.

**WARNING:** Never remove cooling system cap while engine is running or hot; you could get burned.

**Maintenance notes:**

- Rotate tires every 7,500 miles or sooner if needed
- Replace cabin air filter every 25,000 miles or 24 months
- Inspect engine valve clearance every 75,000 miles
- Replace spark plugs every 75,000 miles
- Replace (FL22)\* engine coolant at 120,000 miles

**NORMAL SERVICE INTERVALS**

7,500 miles	A	
15,000 miles	A	F
22,500 miles	A	
30,000 miles	A B	F
37,500 miles	A C	
45,000 miles	A	E F
52,500 miles	A	
60,000 miles	A B D	F
67,500 miles	A	
75,000 miles	A C	F
82,500 miles	A	
90,000 miles	A B	E F

**Tip:** For severe driving conditions, Owner's Manual recommends changing oil and filter at 5,000<sup>†</sup> miles

\* Denotes optional equipment  
† See Owner's Manual

**Break-in period**

First 600 miles: Avoid heavy braking and acceleration; drive at varying road and engine speeds

- A.** Change: Engine oil/replace filter  
Lubricate: Locks and hinges
- B.** Inspect: Fuel lines and hoses, idle speed, brake lines and hoses, steering operation and linkages, front suspension ball joints, driveshaft dust boots, chassis and body bolts
- C.** Inspect: Drive belts (tension)  
Replace: Air filter
- D.** Inspect: Hoses and tubes for emission system  
Replace: Engine coolant (other than FL22), manual transmission oil, rear differential oil
- E.** Inspect: Exhaust system and heat shields
- F.** Inspect: Disc brakes

Always check the Owner's Manual for more operating information and safety features