

## DRIVER ASSURANCE

### **Mazda Driver's Assurance Plan**

Check out [www.mymazda.com](http://www.mymazda.com), the website dedicated to you. Manage your maintenance records, receive valuable offers, see the latest accessories, and much more!

### **Mazda Roadside Assistance**

Exhilaration, liberation and inspiration, are great reasons to drive a Mazda car, truck, SUV or minivan. In addition to all the other great standard features, you also get peace of mind, our Emergency Roadside Assistance Plan, it's just a phone call away, 24 hours a day, 365 days a year, call **1-800-866-1998**

### **Mazda "bumper-to-bumper" Limited Warranty**

We design and build every Mazda to give you driving pleasure now and far down the road. We're so confident in our quality that we cover the entire vehicle against defects in materials and workmanship

for 48 months or 50,000 miles, whichever comes first

### **Mazda Service Transportation Solution**

Being without your Mazda may put a crimp in your day.

If you do ever have to take your Mazda in for repairs don't worry, you're covered. With the Mazda Transportation Solution, you will be given a loaner car at no charge when your Mazda vehicle is in for warranty repairs.

For all the details, see your Mazda Dealer

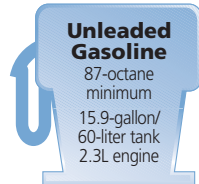

This Quick Tips® guide is provided by Mazda North American Operations to make your Mazda ownership experience more convenient. It is not intended to replace your Owner's Manual.

If you have any questions about your vehicle, you are invited to contact your local dealer.

Or if you need additional help, feel free to call our **Customer Assistance Center at 1-800-222-5500**

Monday through Friday,  
9 a.m.-4:45 p.m., Pacific  
9 a.m.-5:45 p.m., Eastern/Central



©2005 Calcar, Quick Tips® is a trademark of Calcar, made in USA 3/05 30.406M DOT Mazda North American Operations reserves the right to change product specifications at any time without incurring obligations. 9999-95-005C-06QT

2006

## MAZDA 5



### Quick Tips®

Reference  
Guide for  
Controls and  
Functions

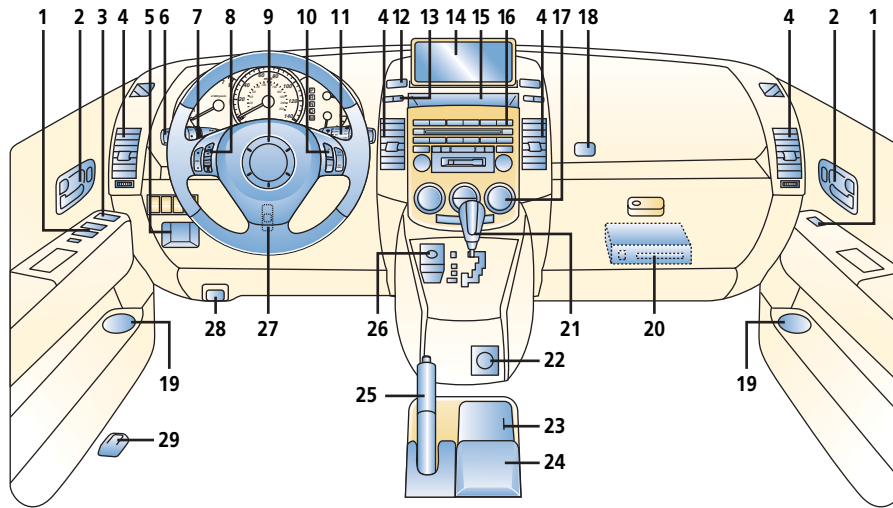

## DRIVER'S VIEW



- |   |  |   |
|---|--|---|
| <p><b>1. Power window switches,</b><br/>see Switches/Clock</p> <p><b>2. Door locks,</b><br/>see Locks</p> <p><b>3. Mirror controls,</b><br/>see Switches/Clock</p> <p><b>4. Air vents</b></p> <p><b>5. Storage</b></p> <p><b>6. Turn signal/lighting control lever,</b><br/>see Getting Started</p> <p><b>7. Fog light switch*,</b><br/>see Getting Started</p> <p><b>8. Audio control switches,</b><br/>see Getting Started</p> <p><b>9. Horn/Air bag</b><br/>To beep: Press</p> <p><b>10. Cruise control,</b><br/>see Getting Started</p> <p><b>11. Wiper/washer control lever,</b><br/>see Getting Started</p> | <p><b>12.  Hazard warning switch/light</b><br/>Push to activate/deactivate</p> <p><b>13. Clock setting buttons,</b><br/>see Switches/Clock</p> <p><b>14. NAVI display*</b><br/>See Owner's Manual</p> <p><b>15. Information display,</b><br/>see Owner's Manual</p> <p><b>16. Audio system,</b><br/>see Audio Systems</p> <p><b>17. Climate control panel,</b><br/>see Climate Controls</p> <p><b>18. Passenger air bag off indicator,</b><br/>see Getting Started</p> <p><b>19. Bottle holder</b><br/><b>CAUTION: Use plastic bottles with caps, cups may spill when door is closed</b></p> <p><b>20. NAVI DVD*</b><br/>Located inside glove box</p> | <p><b>21. Gearshift lever,</b><br/>see Transaxle</p> <p><b>22. Accessory socket</b></p> <p><b>23. Cup holder</b></p> <p><b>24. Center console</b></p> <p><b>25. Parking-brake lever</b><br/>To engage: Pull up<br/>To release: Pull up slightly, while depressing button at front of lever, lower parking brake lever</p> <p><b>26. NAVI remote control*</b></p> <p><b>27. Tilt/telescopic steering wheel lever,</b><br/>see Getting Started</p> <p><b>28.  Hood release handle</b><br/>Pull release handle to unlock</p> <p><b>29.  Fuel-filler lid release</b><br/>To open: Pull lever upward and release</p> |
|---|--|---|

\*Denotes optional equipment

Always check the Owner's Manual for more operating information and safety features

Driver's  
View

## GETTING STARTED

**Getting Started**

MAZDA5 Quick Tips® are designed to quickly familiarize you with some important features of your MAZDA5

The Driver's View tab is your index to the Quick Tips®, locate the item you would like to learn more about and then turn to the listed tab

This Getting Started section contains important operating tips about your MAZDA5

Items identified in blue text call out important information

**Passenger air bag deactivation indicator light**

Front air bag deactivation indicator light (1) provides current status of front passenger air bag and pretensioner system. If total seated weight on front passenger seat is less than approximately 66 lb., front passenger air bag deactivation indicator light illuminates, front passenger and side air bags/pretensioner will not deploy/activate in an accident. If the total seated weight is greater than approximately 93 lb., light does not illuminate, and the front passenger and side air bags/pretensioner will deploy/activate in an appropriate accident.

See Owner's Manual for additional information on this feature and the air bag system

**Passenger sensing operation**  
See Driver's View

PAD indicator on dash will illuminate when passenger side air bag is deactivated, child-restraint seat with child that weighs a combined total of 66 lbs. or less will deactivate front passenger and side air bags/pretensioner, see Owner's Manual

**⚠ WARNINGS: Never place rear-facing infant-safety seat in front of any air bag, an infant is in serious danger of being injured or killed. If you must install a forward-facing child-safety seat in the front seating position, move vehicle seat as far back as possible.**

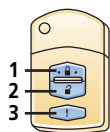
**Remote entry system**

Functions only with ignition key not inserted  
To lock doors and liftgate: Press (1); pressing again within a few seconds causes doors/liftgate to re-lock, horn to beep once and hazard warning lights to flash once if doors/liftgate properly closed  
To unlock: Press (2) for driver's door, hazard warning lights will flash twice, press again within a few seconds for all other doors/liftgate  
Panic alarm: Press (3) for a few seconds; horn sounds, hazard warning lights flash; press any button on transmitter to stop  
After unlocking with the transmitter, all doors or the liftgate will automatically lock if a door or the liftgate is not opened within about 30 seconds

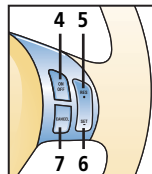
**Cruise control**

Operates above 19 mph  
Press Main switch (4) to turn system on/off  
To set speed: Accelerate to desired speed and press SET- (6)  
To accelerate: Press and hold RES+ (5); release button at desired speed  
To decelerate: Press and hold SET- (6); release button at desired speed  
Incremental acceleration: Press and release (5); each tap = plus 1 mph  
Incremental deceleration: Press and release (6); each tap = minus 1 mph  
To cancel: Press CANCEL (7) or Main switch (4); tap brake pedal or depress clutch pedal\*  
Return to preset speed after CANCEL button or braking: Press and release RES+ button (5)

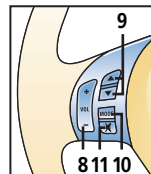
**Steering-wheel audio controls**

To increase/decrease volume: Press (8)  
Radio: Press ▲ / ▼ (9) less than one second to select next/previous preset station, press ▲ / ▼ (9) more than one second until beep sound is heard to seek next/previous station  
Cassette/CD/MD: Press ▲ (9) to select next selection/track, press ▼ (9) to repeat current selection/track  
Press (10) to select AM, FM 1, FM 2, Tape\*, MD\* and CD mode  
Press (11) to mute Audio/NAVI system\*

\*Denotes optional equipment

Always check the Owner's Manual for more operating information and safety features

## GETTING STARTED

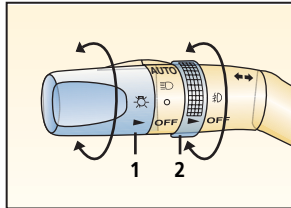
**Turn signal/lighting control lever**

**OFF** = Lights off

○ = Tail, parking and dashboard lights on: Rotate knob (1) to first notch

☰ = Tail, parking, dashboard and headlights on: Rotate knob (1) to second notch

High beams on/off: Push forward/pull back to detent

**AUTO\*** = With ignition switch in ON position; headlights and exterior lights automatically turn ON/OFF depending on surrounding darkness/lightness; rotate knob (1) to third notch

To flash high beams: Pull back slightly and release

Turn signals right/left: move lever up/down

☰ = Fog lights\* on: Rotate (2); functions only with low beams on

**Tip: Headlights switch off, parking lights remain on, if lights are left on and switch is in lock position or key removed**

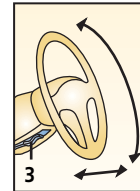
**Tilt/telescopic steering-wheel lever**

Pull lever (3) up to unlock column, position tilt angle and length of steering column position

**WARNING: Do not adjust steering-wheel while driving**

**Tire Pressure Monitoring System (TPMS)\***

Warning light illuminates for a few seconds after ignition is on. If tire pressure is too high or too low, or tire temperature is too high, warning light will illuminate and beeper will sound.

Flashing warning light indicates possible malfunction; dealer inspection required.

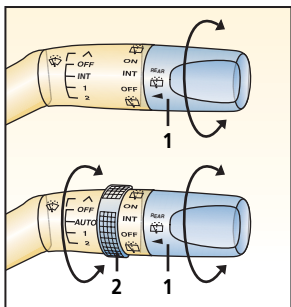
**Wiper/washer control lever**

Single wipe: Push lever up

Washer: Pull back, also operates wipers

Intermittent wiper: One click down

Normal wiper speed: Two clicks down

High-speed wiper: Three clicks down

Auto\*: One click down

Rain sensor senses rain amount on windshield, then controls wiper automatically.

Rain sensor sensitivity is adjusted from high sensitivity (+) to less sensitivity (-) by rotating ring (2).

**Rear window wiper/washer**

To activate rear interval wiper: Rotate knob (1) up to INT

To activate rear normal speed wiper: Rotate knob (1) up to ON

To activate rear washer: Rotate knob (1) to  and release

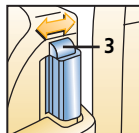
**Sliding doors**

Lock/unlock from interior: Slide door-lock knob (3) toward front/toward back

Locking from exterior: Slide door-lock knob toward front and close door

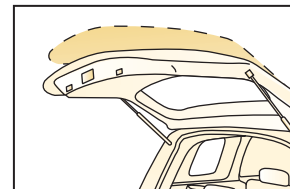
**Liftgate**

Liftgate opens in 2 positions, first position is slightly lower than fully open position, do not use excessive force while pushing liftgate to fully open position.

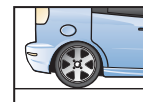
**Fuel filler door**

Located on passenger side

\*Denotes optional equipment

Always check the Owner's Manual for more operating information and safety features

## Instrument Cluster

### INSTRUMENT CLUSTER

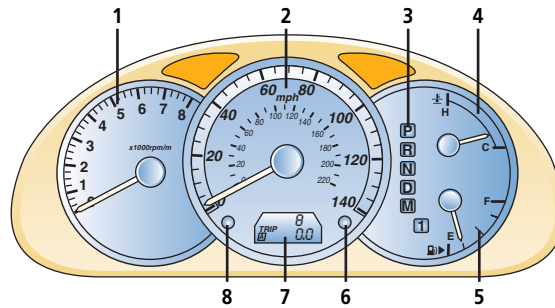

#### GAUGES

- 1. Tachometer**
- 2. Speedometer**
- 3. Gear indicator (A/T only)\***  
Displays current gear position
- 4. Engine coolant temperature gauge**  
Stop car if above normal range, turn off engine, let vehicle cool; check coolant level when safe
- 5. Fuel gauge**  
15.9-gallon/60-liter tank
- 6. Odometer/Trip meter selector**  
Press to view odometer; press again to reset trip odometer A/B settings
- 7. Odometer/Trip meter**
- 8. Instrument cluster dimmer select button\***

#### WARNING LIGHTS

- **CRUISE** **Cruise control on**, see Getting Started
- **CRUISE MAIN** **Cruise control main power on**, see Getting Started
- **Tire Pressure Monitoring System (TPMS)\***, see Getting Started
- **Turn signals/hazard warning on**
- **High beams on**
- **Engine oil-pressure warning light**  
Stop car when safe and turn off engine; check oil level
- **Brake system**  
Parking brake on/low brake fluid
- **Always fasten seat belts**
- **Security indicator light\***
- **Charging system warning light**  
Charging system malfunction; dealer inspection required
- **Air bag/front seat belt pretensioner system**  
If light flashes or stays on, the air bags/front seat belt pretensioners may not operate in an accident; dealer inspection required
- **Power steering malfunction**  
Dealer inspection required if light remains on
- **Check engine**  
Dealer inspection required if light remains on, see Owner's Manual
- **AT Automatic transaxle warning light\***  
Automatic transaxle malfunction; dealer inspection required
- **Low fuel**
- **Low washer fluid level warning light**
- **Door ajar**
- **Anti-lock Brake System (ABS)**  
ABS malfunction, normal brakes only; dealer inspection required

\*Denotes optional equipment

Always check the Owner's Manual for more operating information and safety features

## Instrument Cluster

## Locks

### LOCKS

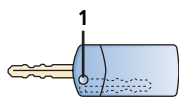

**Key**  
Operates ignition and all locks

**Tip:** Use key number plate to purchase a new key; store in safe place separate from vehicle

**Retractable Key**  
To fold/unfold press release button (1)



**Remote entry system**  
See Getting Started

**Illuminated entry system**  
Activates interior lights when dome light switch set to DOOR position; lights off after driver's door is locked or ignition in ON position

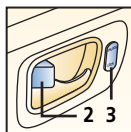

#### Manual door locks Lock button

To lock: Press front of button (2) toward door handle

To unlock: Pull front of button away from door handle

#### Power door locks Master front door locks switches

To lock/unlock all doors: Press bottom/top of switch (3)

To lock doors without key: With door open, press bottom of door lock switch, exit car, close doors

To unlock: Use key to unlock driver's front door, rotate key to counter-clockwise position for more than one second to unlock other doors

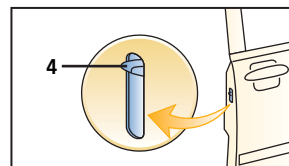

#### Child-safety locks

Located at edge of rear doors

To activate: Pull tab (4) down; door opens from outside only

To cancel: Push tab (4) up

**WARNINGS:** Since children may access either rear door, child-safety locks for both rear doors should be activated

**Never leave a child in car with key in ignition**

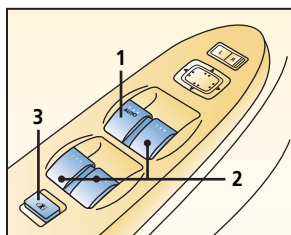

#### Power windows

Ignition must be on

All windows controlled from the driver's armrest; passenger doors have separate switches

**1.** Driver's window: One-touch-down; push down firmly and release, window goes down all the way; pull switch back briefly to stop; press lightly and hold for normal operation

**2.** Passenger window switches: Push down and hold to open, pull back and hold to close

**3.** Power window lockout switch: Press down until it clicks, only driver's window operates; press again and passenger window switches function again

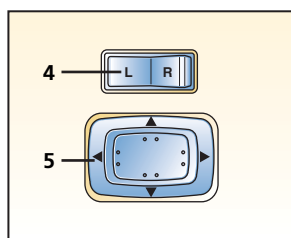

#### Dual power mirrors

Ignition must be in ACC or ON

To adjust left/right mirror: Press control switch (4) left/right, press switch (5) in direction of desired mirror movement

**Tip:** To lock mirrors in place, move control switch to center position

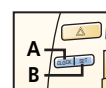

#### Clock

To set: With ignition in ACC or ON position, press (A) and hold until beep sounds; 12hr/24hr will be displayed; press (B) to select; press (A) again while selection is flashing: Hr ADJUST displays; press (B) to select hour; press (A) when done, do the same to set minutes

Always check the Owner's Manual for more operating information and safety features

Switches/  
Clock

## Interior Lights

### INTERIOR LIGHTS

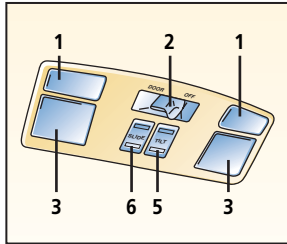

- 1. Map/reading light switch**  
Press on/off
- 2. Interior light switch**  
DOOR = light on when door open  
ON = light always on  
OFF = light always off
- 3. Front interior light**
- 4. Rear interior light**

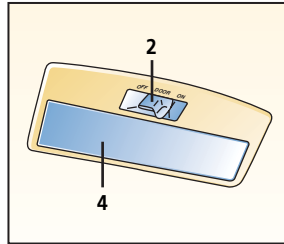

- 5. Sunroof tilt switch\***  
Press rear of switch to tilt rear of sunroof  
Press front of switch to close
- 6. Sunroof slide switch\***  
Press rear of switch to open sunroof  
Press front of switch to close

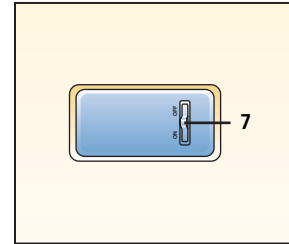

- 7. Cargo light**  
ON = Light always on  
OFF = Light always off
- Driver/passenger covered visor mirrors**  
To access mirror: Lower visor

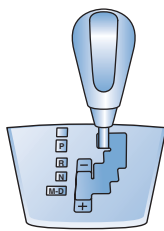

#### Automatic Transaxle\*

Gearshift must be in Park or Neutral to start engine; it must be in Park to remove ignition key

- P = Park**  
To move gearshift from Park: Press firmly on brake pedal then move the shift lever out of P
- R = Reverse**
- N = Neutral**  
No gear engaged
- D Drive (Overdrive)**  
For normal driving: Shifts through all forward gears automatically



#### M (Sport A/T manual shift mode)

Move shifter from D to M to engage manual shift mode, M will be illuminated for manual mode on shift position indicator located in the instrument panel  
Manual shifting of transmission is achieved by moving shifter back to upshift and forward to downshift, move shifter from M to D to engage automatic shift mode

#### Gear indicator (A/T only)\*

Illuminated numeral of gear indicator located in the instrument panel displays current gear in Automatic and Manual shift modes

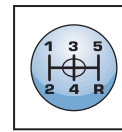

#### Manual transaxle

Depress clutch pedal to start engine and change gears

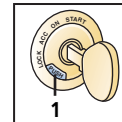

#### Ignition key release button (M/T only)

Press button (1) to remove key from ignition

**Tips:** Do not shift into 1st above 20 mph or clutch failure could occur  
Resting your foot on clutch pedal while driving or using the clutch to hold your vehicle at a standstill while waiting on a hill may reduce clutch life

\*Denotes optional equipment

Always check the Owner's Manual for more operating information and safety features

Transaxle

## Climate Controls

### CLIMATE CONTROLS

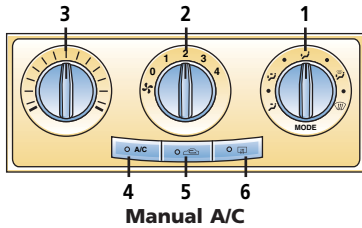

Manual A/C

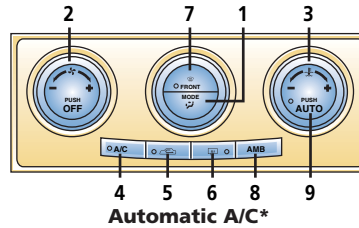

Automatic A/C\*

#### 1. Air flow selections

- = air to dash
- = air to dash and floor
- = air to floor
- = air to floor and windshield
- = air to windshield (defrost)  
(Manual Climate Control)

#### 5. Air intake control

Press switch to alternate between recirculated (Indicator light on) or outside (Indicator light off) air mode

= recirculate inside air; use for maximum cooling

**⚠ WARNING: Do not use position in cold weather, windows may fog and hamper vision**

#### 8. AMB\*

Press AMB switch to display ambient temperature

#### Control positions for maximum defrost

Fan to maximum, temperature to maximum hot, selected

**☀ Tip: To help prevent windshield fogging in humid weather, select before starting engine**

#### 2. Fan control

Rotate knob clockwise/counterclockwise to increase/decrease fan speed

#### 3. Temperature control

Cooler/warmer = rotate knob counterclockwise/clockwise

#### 4. A/C = air conditioner

Press to turn on/off

#### 6. Rear window defogger

Press on/off; shuts off with ignition or automatically after 15 minutes of operation; also operates heated outside mirrors\*

#### 7. Windshield defroster switch

Press: Fresh air position is automatically selected, A/C automatically turns ON

**☀ Tips: To prevent moisture buildup, never drive with system off**  
**Objects placed under the front seats may interfere with air flow to the rear**  
**Automatic operation**

Press AUTO (9) for automatic operation; rotate outer dial to set temperature, see Owner's Manual

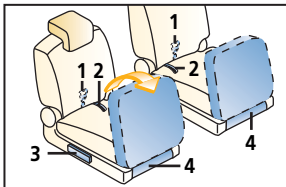

#### Rear passenger exiting

Pull (1) and fold seatback forward

**☀ Tip: Second-row under seat storage\* (4)**

#### Folding second-row seats

Insert second-row outboard seat belts in retainers; lower head restraint; pull strap (2) and lift seat-bottom forward; raise lever (3) and fold seatback forward

#### Returning seatbacks to original positions:

Raise lever (3) and return seatback to upward position; return seat-bottom to original position. Make sure seatback and seat-bottom are locked into position

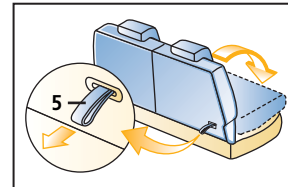

#### Third-row seat (50/50 split)

To fold down: Pull (5), then fold seatback down

\*Denotes optional equipment

Always check the Owner's Manual for more operating information and safety features

Seats



SEATS

**Shoulder belt height adjustment**

To raise/lower belt: Pull button (1), slide up/down, release button

**⚠ WARNING: Make sure adjuster locks in one of its positions**

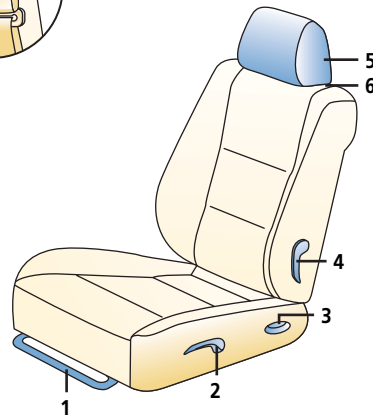
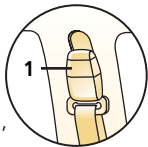

**Seat controls**

**1. Fore-aft adjustment**

Lift lever and hold, slide seat, release lever

**2. Raise/lower seat (Driver's seat only)**

Pull/push lever and release

**3. Seat back angle**

To adjust: Lift and hold lever, lean forward or backward to tilt seat, release lever

**4. Lumbar support adjustment\* (Driver's seat only)**

Pull lever forward

**5. Head restraint**

To raise/lower: Pull up/hold release button (6) and push down

**☀ Tip: Side-impact air bags\* deploy from outboard side of front seatbacks**

**⚠ WARNINGS: Do not adjust seats while driving**  
Safety belts must always be worn when vehicle is in motion

Air bags are supplemental and do not replace safety belt usage

Always wear your safety belt and properly secure children 12 and under in the rear seat

Never place rear-facing infant-safety seat in front of any air bag, an infant is in serious danger of being injured or killed

If you must install a forward-facing child-safety seat in the front seating position, move vehicle seat as far back as possible

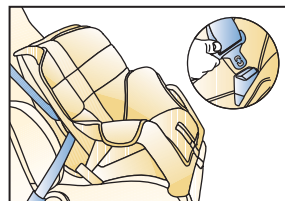

**Child-safety seat**

To install in rear outboard seats: Use dual locking mode retractor seat belts; see Owner's Manual for proper installation and child seat tether and LATCH system instructions

**⚠ WARNING: Use age appropriate child restraints, see Owner's Manual and state or province laws**

**Safety belt emergency locking mode**

Belts lock only on hard acceleration, braking, cornering or impacts of about 5 mph or more

**Automatic locking mode (front passenger and all rear safety belts only)**

Must be used when installing child-safety seat

To activate: Pull webbing fully out of retractor, allow belt to retract until click is heard; belt will only tighten

To disengage: Unbuckle belt and allow webbing to retract fully

\*Denotes optional equipment

Always check the Owner's Manual for more operating information and safety features

## Audio Systems

### AM / FM STEREO / CASSETTE / CD / MD / MP3

#### 1. Power/Volume

Press to turn on/off; rotate to increase/decrease volume

#### 2. Disc ^ / v \*

Press to skip to next/previous CD

#### 3. Memory preset buttons

To set: Tune to station, press and hold until beep sound is heard

#### 4. LOAD\*

To load multiple discs: Press and hold LOAD (4) until beep sound is heard; insert CD when "In" is displayed

To eject disc: Press Eject (11)  
To eject specific disc: Press and hold Eject (11) until beep sound is heard; within five seconds press the desired tray number 1-6 (3)

#### 5. CD slot

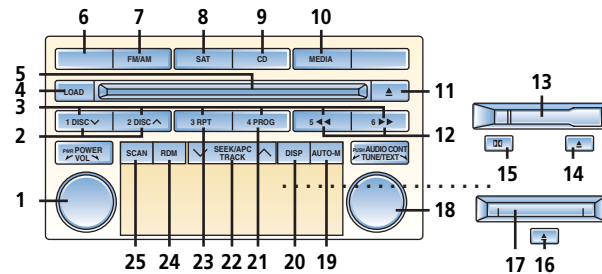

#### 16. MD eject button\*

#### 17. MD slot\*

#### 18. Tune/Text/Audio control

Radio: Rotate counter clockwise/clockwise for lower/higher frequency

Audio: Press to select ALC/BASS/TREB/FADE/BAL/BEEP

#### 22. SEEK/APC/TRACK

Radio: Press ▲ / ▼ to automatically seek higher/lower frequency  
CD/MD/MP3: Press ▲ / ▼ to select next track/beginning of current track

#### 6. In-dash CD Changer\*

See Owner's Manual

#### 7. FM/AM

Press to turn radio on and select between FM1/FM2/AM station preset buttons (3)

#### 8. SAT\*, Satellite ready capability

#### 9. CD, Press to play CD

#### 10. Media\*

Press to play MD or tape

#### 11. CD eject button

#### 12. Reverse ◀ / Fast forward ▶▶

Press to reverse/fast forward through a track or rewind/fast forward a tape

#### 13. Cassette tape slot\*

#### 14. Tape eject button\*

#### 15. Dolby® Noise Reduction button\*

Press when playing a tape with Dolby noise reduction, press again to cancel

Rotate right/left to adjust selected feature

Text\*(MD and MP3): Rotate right/left to display titles

**Tip: Automatic Level Control (ALC) automatically adjusts audio volume depending on vehicle speed**

#### 19. Auto-Memory

Press and hold until a beep sound is heard; system automatically scans and temporarily stores six strong stations in each band; press again to switch to another preset station

#### 20. DISP

CD/MD/MP3: Press repeatedly to scroll through displays

#### 21. Program\*

Press to change cassette tape-play direction

Tape: Press ▲ / ▼ to automatically advance tape to beginning of next selection/replay selection; to stop this operation, press button again

#### 23. RPT

Press to replay current CD/MD/MP3/tape selection

#### 24. Random

Press to play CD/MD/MP3 selections in random order, press again to cancel

#### 25. Scan

Radio: Press to sample strong stations, press again to stop at current station

CD/MD/MP3: Press to play first few seconds of each selection, press again to stop at current selection

\*Denotes optional equipment

Always check the Owner's Manual for more operating information and safety features

Audio Systems

## Cargo Area

### CARGO AREA

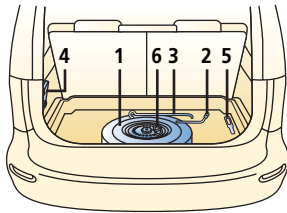

#### Spare tire

##### 1. Temporary spare tire

Stored under panel in trunk; to change flat tire: Follow instructions in Owner's Manual

**⚠️ WARNING: Do not exceed 50 mph with temporary spare**

**☀️ Tip: For instructions and restrictions on use of temporary spare tire, see Owner's Manual**

##### 2. Lug wrench

##### 3. Jack handle

##### 4. Jack

##### 5. Tie down eyelet

##### 6. Flat tire belt storage bag

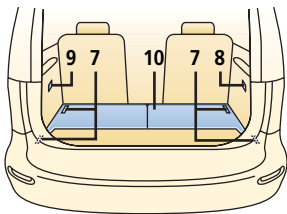

#### Cargo area

##### 7. Cargo securing loops

##### 8. Cargo light

##### 9. Accessory socket

##### 10. Third-row seat

#### Tire economy and tips

Check tire pressure monthly when tires are cold, use a digital tire pressure gauge for accurate tire pressure measurement

Tires should be of the same type and size

Maintain correct front-end alignment and tire balance; rotate tires at 7,500-mile intervals; see Owner's Manual for rotation chart

#### Tire pressure

Decal on Driver's B-pillar provides tire pressure information

#### Tire chains\*†

Use only SAE Class "S" chains; install on front tires as tightly as possible and re-tighten periodically; do not use chains on dry roads, aluminum wheels, or with tire pressure monitor system, damage may occur, use on steel wheels only

#### Anti-lock Braking System (ABS)

ABS automatically reduces hydraulic pressure to any wheel on the verge of locking up

You may feel a slight pulsing of the brake pedal and hear a clicking noise; this tells you the ABS is functioning properly; increase pressure on pedal for maximum braking

**☀️ Tips: Maintain constant pressure on the brake pedal. Do not pump the brakes**

#### ABS self test

A self-diagnostic test is performed when starting; you may feel some brake pedal pulsation and hear some noise, this is normal

#### Gas cap

After filling vehicle with gasoline, fully reinstall gas cap by turning clockwise until a clicking sound is heard, if gas cap is not fully installed, Check Engine light may come on

For more information on Check Engine light, see Owner's Manual

\*Denotes optional equipment  
† See Owner's Manual

**Always check the Owner's Manual for more operating information and safety features**

## Driving Tips

## Under Hood

### UNDER HOOD

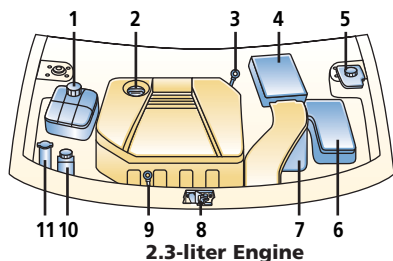

#### 1. Engine coolant reservoir

Level should be between COLD FILL RANGE indicator marks

**⚠ WARNING: Never remove coolant reservoir cap while engine is running or hot; remove only when safe**

#### 2. Engine oil filler cap

See Owner's Manual for recommended engine oil viscosity

#### 3. Automatic transaxle fluid dipstick\*

Check with transaxle in park, engine on and at operating temperature; fluid level must be between the indicator marks on the dipstick

#### 4. Battery

5. Brake/clutch fluid reservoir  
Fill to MAX mark with DOT 3 fluid; check with cap on

**☀ Tip: Clutch uses same reservoir as brakes**

#### 6. Fuse panel

Push latch in; lift cover

#### 7. Air filter

#### 8. Hood latch

Pull up to release hood

#### 9. Engine oil dipstick

Fluid should be between F and L on dipstick; do not fill above F

#### 10. Power steering fluid reservoir

Level should be between MIN and MAX lines

#### 11. Windshield washer reservoir

Fill with windshield washer fluid

**☀ Tip: Check all fluids with vehicle parked on a level surface and engine off unless otherwise stated**

#### Break-in period

First 600 miles: Avoid heavy braking and acceleration; drive at varying road and engine speeds

**☀ Tip: Follow the same procedures with newly overhauled engine or when brakes are replaced**

#### Maintenance notes:

Rotate tires every 7,500 miles or sooner if needed  
Replace cabin air filter every 25,000 miles or 24 months  
Replace (FL22)\* engine coolant at 120,000 miles

**☀ Tip: For severe driving conditions, Owner's Manual recommends changing oil and filter at 5,000<sup>†</sup> miles**

#### NORMAL SERVICE INTERVALS

7,500 miles	A
15,000 miles	A F
22,500 miles	A
30,000 miles	A B F
37,500 miles	A C
45,000 miles	A F G
52,500 miles	A
60,000 miles	A B D F
67,500 miles	A
75,000 miles	A C E F
82,500 miles	A
90,000 miles	A B F G

**☀ Tip: For additional service intervals and complete details, see Owner's Manual**

A. Replace: Engine oil and filter<sup>†</sup>  
Lubricate: All locks and hinges

B. Inspect: Fuel lines and hoses, brake lines, hoses and connections, steering operation and linkages, front and rear suspension and ball joints, drive-shaft dust boots

C. Inspect: Drive belts (tension)  
Replace: Air filter

D. Inspect: Hoses and tubes for emission system  
Replace: Engine coolant (Other than FL22)

E. Inspect: Engine valve clearance  
Replace: Spark plugs

F. Inspect: Disc brakes

G. Inspect: Exhaust system and heat shields

\*Denotes optional equipment

<sup>†</sup>See Owner's Manual

Always check the Owner's Manual for more operating information and safety features