

DRIVER ASSURANCE

Mazda Drivers Assurance Plan
Check out www.mymazda.com, the website dedicated to you. Manage your maintenance records, receive valuable offers, see the latest accessories and much more!

Mazda Roadside Assistance
Exhilaration, liberation and inspiration are great reasons to drive a Mazda car, truck, SUV or minivan. In addition to all the other great standard features, you also get peace of mind, our Emergency Roadside Assistance Plan, it's just a phone call away, 24 hours a day, 365 days a year, call **1-800-866-1998**.

Mazda "bumper-to-bumper" Limited Warranty
We design and build every Mazda to give you driving pleasure now and far down the road. We're so confident in our quality that we cover the entire vehicle against defects in materials and workmanship

for 48 months or 50,000 miles, whichever comes first.

Mazda Service Transportation Solution
Being without your Mazda may put a crimp in your day, if you do ever have to take your Mazda in for repairs don't worry, you're covered. With the Mazda Transportation Solution, you will be given a loaner car at no charge when your Mazda vehicle is in for warranty repairs. For all the details, see your Mazda Dealer.

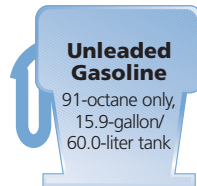

This Quick Tips® guide is provided by Mazda North American Operations to make your Mazda ownership experience more convenient. It is not intended to replace your Owner's Manual.

If you have any questions about your vehicle, you are invited to contact your local dealer. Or if you need additional help, feel free to call our **Customer Assistance Center at 1-800-222-5500** Monday through Friday, 8 a.m.-4:45 p.m., Pacific 9 a.m.-5:45 p.m., Eastern/Central



©2006 Calcar, Quick Tips® is a trademark of Calcar, made in USA 8/05 32.95M DOT Mazda North American Operations reserves the right to change product specifications at any time without incurring obligations. 9999-95-079C-06QT

2006

MAZDA RX-8

Quick Tips®

Reference
Guide for
Controls and
Functions



DRIVER'S VIEW

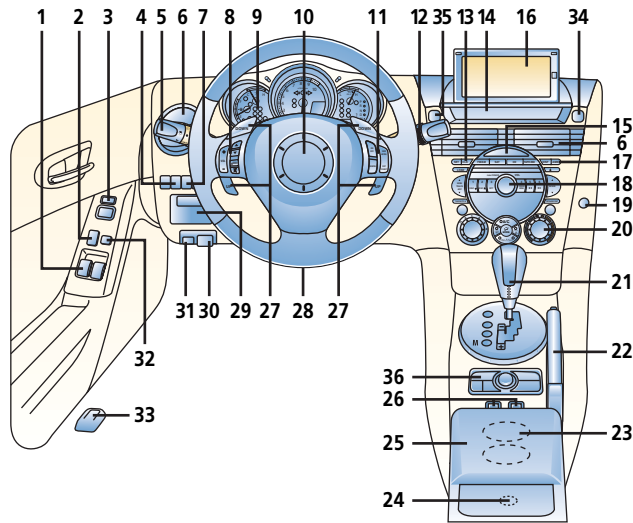





Getting Started

RX-8 Quick Tips® are designed to quickly familiarize you with some important features of your RX-8

This Driver's View tab is your index to the Quick Tips®, locate the item you would like to learn more about and then turn to the listed tab

Be sure to see the tab called Getting Started, this section contains important operating tips about your RX-8

Items identified in blue text call out important information

- | | | |
|--|--|---|
| 1. Power window switches, see Switches | 13. Clock, see Audio Systems | 26. Seat warmer switches*, see Console |
| 2. Power door locks, see Locks | 14. Information display, see Owner's Manual | 27. Steering paddle switches (A/T only)*, see Transmission |
| 3. Dual power mirrors, see Switches | 15.  Hazard warning switch, Press on/off | 28. Tilt steering-wheel lever, see Driver Controls |
| 4.  Instrument panel lighting, see Getting Started | 16. NAVI system*, see Owner's Manual | 29. Storage |
| 5. Turn signal/lighting control lever, see Driver Controls | 17. Ambient temperature display | 30.  Hood release handle |
| 6. Air vents | 18. Audio system, see Audio Systems | 31.  Remote trunk-lid release |
| 7. ^{DSC} Dynamic Stability Control System*, see Getting Started | 19. Passenger air bag off indicator, see Seats | 32. Power window lock switch |
| 8. Audio control switches*, see Driver Controls | 20. Climate control panel, see Climate Controls | 33.  Remote fuel-door release |
| 9. Tire pressure monitoring system, see Getting Started | 21. Gearshift lever (A/T)*, see Transmission | 34. Open/close NAVI screen* |
| 10. Horn/Air bag | 22. Parking brake lever, see Console | 35. NAVI screen tilt* |
| 11. Cruise control, see Driver Controls | 23. Cup holders | 36. NAVI system remote control* |
| 12. Wiper/washer control lever, see Driver Controls | 24. Accessory socket | |
| | 25. Console, see Console | |

*Denotes optional equipment

Always check the Owner's Manual for more operating information and safety features

Driver's
View

GETTING STARTED

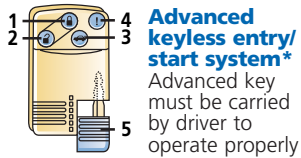
**Advanced keyless entry/start system***

Advanced key must be carried by driver to operate properly

Refer to Owner's Manual for additional instructions

Tip: System may not operate correctly if vehicle is near equipment such as wireless pay devices located at some gas stations, if this occurs, use auxiliary key to lock/unlock and start vehicle

Advanced keyless system customization

Your authorized Mazda Dealer can customize your system if desired with features such as auto-lock: After exiting the vehicle after driving, the car will automatically lock

For additional information on customizable features, see Owner's Manual

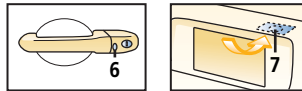
**Locking doors**

Driver's/passenger's door request switch: Press (6) on either door to lock both doors

Advanced key transmitter: Press (1) button; pressing again within a few seconds causes doors to relock and horn to beep

Unlocking doors/opening trunk

Driver's door request switch: Press (6) to unlock driver's door; press again within 3 seconds to unlock both doors

Passenger's door request switch: Press (6) on passenger's door; both doors unlock simultaneously

Trunk request switch: Press (7) located above license plate, only trunk will open, doors do not lock/unlock

Advanced key transmitter: Press (2) button for driver's door; press again within a 3 seconds to unlock passenger's door

Press and hold (3) for more than 1 second to open trunk

Activating panic alarm

Panic alarm: Press and hold (4) for more than 1 second; horn sounds, hazard warning lights flash; to stop, press any remote button

*Denotes optional equipment

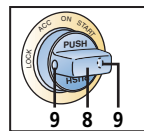
**Starting engine**

Press start knob (8); when KEY indicator (green) illuminates on instrument

cluster; turn start knob (8) to START position to start engine

Tip: Engine will not start if trunk is open and advanced key is placed in trunk

Auxiliary key operation

If advanced key cannot be used due to a malfunction or dead battery, use auxiliary key (5) to lock/unlock doors, trunk and to start vehicle

To start vehicle: Remove start knob cover (8) by pressing both side release buttons (9) while pulling; insert auxiliary key into key cylinder and turn to start engine

Tip: Do not place advanced key on or around dashboard, storage

compartments such as glove box or in open trunk, engine may not start or warnings may activate

Turning off engine

Turn start knob to ACC position to turn engine off, push in and turn start knob to LOCK position

Tip: Vehicle battery may be discharged if start knob is left in ACC position

Always put vehicle in Park (P), set parking brake and turn start knob to LOCK position when exiting vehicle

System operation warnings

KEY indicator light flashes (green) indicates advanced key transmitter battery power is low

KEY indicator light illuminated continuously (red) indicates system malfunction, and auxiliary key should be used, have vehicle inspected at an Authorized Mazda Dealer as soon as possible

Tip: When using advanced keyless system, system will beep as confirmation of lock/unlock requests, system will also beep if start knob is left in ACC position, advanced key has been left in vehicle or if advanced key is removed from vehicle while vehicle is running

For additional system operation warnings, see Owner's Manual

Replacing battery

See Owner's Manual for complete instructions

Cautions on use

To avoid damage to advanced key, do not allow any severe impacts or contact with liquids, do not place heavy objects on advanced key and do not leave advanced key exposed to direct sunlight or high temperatures. See Owner's Manual for all cautions and warnings

Always check the Owner's Manual for more operating information and safety features

GETTING STARTED

Starting tips

To keep engine in top condition, engine coolant temperature gauge needle should reach the middle normal operating range between C and H before turning engine off, do not turn OFF a cold engine if possible. In the unlikely event that the engine does not start, try the following procedure:

1. Depress and hold the accelerator pedal to floor and crank engine for 7-8 seconds
2. Release ignition switch
3. Start the engine, releasing accelerator pedal

If the engine starts while in step 1, the engine will rev up, in that case, release your hand immediately from the ignition key and your foot from accelerator pedal

If the engine still fails to start, have your vehicle inspected at the dealer

- Do not keep holding ignition switch in START position for more than ten seconds, if the engine does not start, it may result in a weakened or dead battery
- Please avoid racing engine or sudden take off right after starting the engine
- If these starting tips are not followed, engine may be DAMAGED as a result

Short trip driving procedure

For any trip that is too short for the engine to reach normal operating temperature, (needle in middle of temperature gauge indicates normal temperature), the following procedure should be followed**:

1. Start engine
2. Move vehicle

3. Warm engine for 5-minutes at idle
4. Raise engine speed to 3000 RPM for 10-seconds
5. Return to idle
6. Turn off engine

 **Tip: Warming up engine improves engine life**

Instrument panel lighting

With headlights on: To brighten/dim turn thumbwheel up/down
Maximum illumination: Rotate thumbwheel upward until click is heard; instrument cluster and information display illumination color goes from red to white
Headlights/parking lights OFF: Instrument panel lighting defaults to maximum brightness
Headlights/parking lights ON: Illumination changes brightness with dimmer switch adjustment

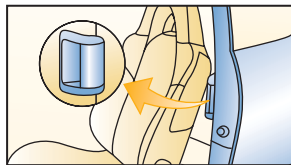
**Rear doors**

For a rear occupant to exit with a front passenger:

1. Front occupant must release seatbelt
2. Front occupant must open door
3. Open rear door

For a rear occupant to exit without a front occupant:

1. Release front seat to forward position
2. Unlock and open front door
3. Open rear door

 **Tip: Close rear door first, then front door; damage may occur otherwise**

Instant Mobility System emergency flat tire repair kit (IMS)

Temporary spare tire is not equipped with your Mazda, if tire repair is required, repair tire with emergency flat tire repair kit, see Owner's Manual

If a temporary spare tire is required, consult your Authorized Mazda Dealer

 **Tire pressure monitoring system**

Warning light illuminates for a few seconds when ignition is on. If tire pressure is too high or low, or tire temperature is too high, warning light will illuminate

 **Traction Control System (TCS)* / Dynamic Stability Control (DSC)***

DSC light may occasionally flash while driving, this indicates that the DSC was performing a correction to help maintain your best vehicle control, if DSC light remains on, see your Mazda Dealer

If DSC light remains on after disconnecting battery or jump-starting, you will need to perform a Steering Angle Sensor calibration procedure, after battery power is restored: Ignition ON; turn steering wheel to full left lock position; then full right lock position; turn ignition OFF, then ON

*Denotes optional equipment

**Moving vehicle at a car wash or moving vehicle to access another vehicle would be considered a short distance

Always check the Owner's Manual for more operating information and safety features

Instrument Cluster

INSTRUMENT CLUSTER

GAUGES

1. Fuel gauge

2. Engine coolant temperature gauge

If above normal range, stop vehicle and turn off engine, check coolant level when safe

3. Speed unit selector

Select km/h or mph

4. Tachometer

5. Engine over-rev warning buzzer

The rotary engine design allows RPM ranges of up to 7500 RPM (A/T) and 9000 RPM (M/T), if you exceed a given RPM, a warning buzzer will remind you to up-shift to the next higher gear

Always obey all local speed limits and traffic signs

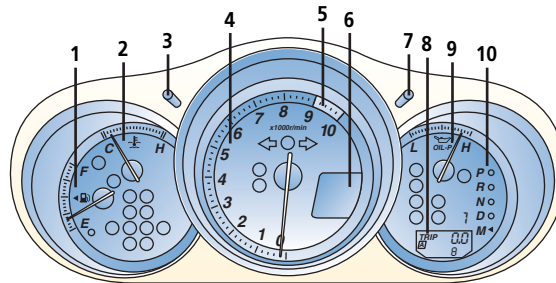

6. Speedometer

7. Odometer/trip odometer selector

Press and hold to reset selected trip meter

8. Odometer/trip odometer

9. Engine oil pressure gauge,

Indicates normal engine oil pressure when needle is halfway between L and H with engine running

10. Gear indicator (A/T only)*

Displays current gear of Sport A/T during manual and automatic shift modes

WARNING LIGHTS

- **Low fuel**
- **Turn signals/hazard warning on**

• **Anti-lock Brake System (ABS)**

ABS malfunction, normal brakes only, dealer inspection required

- **Automatic transaxle**
Dealer inspection required if light remains on

• **High beams on**

• **Charging system**

Dealer inspection required

• **Tire pressure monitoring system**, see Getting Started

• **Lights on**

• **Dynamic Stability Control/Traction Control System* off**

System turned off manually

• **Traction Control System (TCS)* / Dynamic Stability Control (DSC)***, see Getting Started

- **Cruise control on**, Amber light: Cruise control system activated
Green light: Cruising speed set; see Driver Controls

• **Brake system**

Parking brake on/low fluid level

• **Check engine**

Dealer inspection required

• **EBD malfunction**

Dealer inspection required

• **Immobilizer system**, see Locks

• **KEY***, see Getting Started

• **Low washer fluid level***

• **Headlight auto leveling malfunction**

• **Power steering malfunction**

Dealer inspection required if light remains on

• **Engine coolant level**

- **Air bag readiness**
Front, side and curtain air bag malfunction; warning light constantly flashes or stays on or never comes on with ignition on, dealer inspection required

• **Door ajar**

• **Always fasten safety belts**

- **Engine oil level**
Indicates low engine oil if illuminated; pull over to a safe location; turn engine off and check engine oil level when engine is cool, add engine oil if necessary

*Denotes optional equipment

Always check the Owner's Manual for more operating information and safety features

Instrument Cluster

Driver Controls

DRIVER CONTROLS

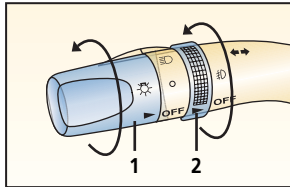

Turn signal/lighting control lever

OFF = Lights off

☺ = Tail, parking and dashboard lights on: Rotate knob (1) to first notch

☺ = Tail, parking, dashboard and headlights on: Rotate knob (1) to second notch

High beams on/off: Push forward/pull back to detent

To flash high beams: Pull back slightly and release

Turn signals right/left: move lever up/down

☺ = Fog lights on: Rotate (2); functions only with headlight low beams on

Tip: Headlights switch off, parking lights remain on, if lights are left on and switch is in lock position or key removed

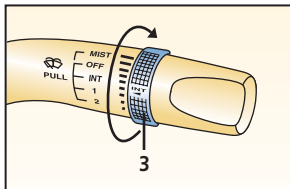

Wiper/washer control lever

Intermittent wiper:

One click down

To change interval speed: Rotate inner ring (3)

Normal wiper speed: Two clicks down

Fast wiper speed: Three clicks down

Single wipe: Push stalk up

Washer: Pull stalk back

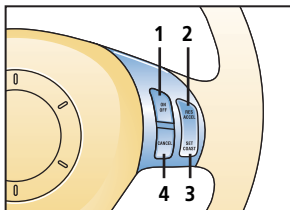

Cruise control

Operates above 19 mph

To activate: Press and release ON/OFF (1)

To set speed: Press and release SET/COAST (3) at desired speed

To accelerate: Press and hold RES/ACCEL (2); incremental acceleration: Press and release (2), each tap = plus 1 mph

To decelerate: Press and hold SET/COAST (3), release at desired

speed; or tap brake pedal, press and release (3) at desired speed; incremental deceleration: Press and release (3), each tap = minus 1 mph

To cancel: Tap brake pedal, clutch pedal (manual transaxle) or press CANCEL button (4) or ON/OFF (1)

Return to preset speed after CANCEL button or braking: Press and release RES/ACCEL button (2)

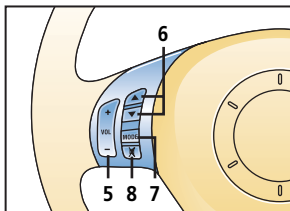

Steering-wheel audio controls

To increase/decrease volume: Press (5)

Radio: Press (6) to select preset stations

Cassette/CD/MD: Press (6) to select next selection/track

Press (7) to select FM1, FM2, AM, CD, SIRIUS 1/2/3, tape and MD mode

Press (8) to mute

Tilt steering-wheel lever

Pull lever located under steering-wheel down to unlock column, position tilt angle steering column position

WARNING: Do not adjust steering-wheel while driving, you can lose control of vehicle

*Denotes optional equipment

Always check the Owner's Manual for more operating information and safety features

Driver Controls

Locks

LOCKS

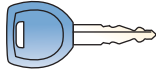

Key

Operates ignition and all locks

 **Tip: Use key number plate to purchase new key; store in safe place**

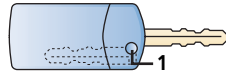

Retractable key

Unfold key: Press (1)

Fold key: Press (1) and rotate key into holder

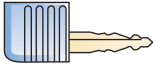

Auxiliary key*

See Getting Started

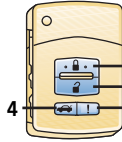

Remote keyless entry system*

Functions only with ignition in OFF position and key removed from ignition cylinder

To lock doors: Press  button (2); pressing again within 5 seconds causes doors to relock and horn to beep

To unlock: Press  button (3) for driver's door; press again within 3 seconds to unlock passenger's door

Press and hold  button (4) for more than 1 second to open trunk

Panic alarm: Press and hold  button (5) for more than 1 second; horn sounds, hazard warning lights flash; to stop, press any remote button



Advanced keyless entry/start system/auxiliary key*

See Getting Started

Immobilizer system

Prevents engine from running unless coded key is used, see Owner's Manual

 **WARNING: Never leave children unattended with key in vehicle or access to keys**

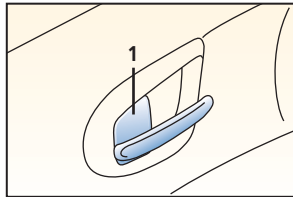

Manual door locks Lock button

To lock: Press front of button (1) toward door handle

To unlock: Pull front of button away from door handle

 **Tips: Doors can be locked with key in ignition (chime sounds to alert you to key in ignition)**

Locking doors with inside door lock knob will not arm system

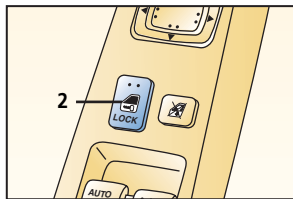

Power door locks Master front door lock switches

To lock/unlock all doors: Press bottom/top of switch (2)

To lock doors without key: With door open, press bottom of door lock switch, exit car, close doors

To unlock: Use key to unlock driver's front door, rotate key to counterclockwise position for more than one second to unlock other doors

*Denotes optional equipment

Always check the Owner's Manual for more operating information and safety features

Locks

Switches

SWITCHES

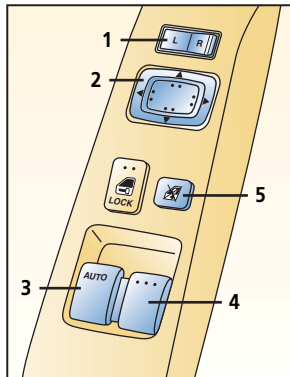

Dual power mirrors

Ignition switch must be in ACC or ON position.

Switch is on driver's door.

To adjust left/right mirror:

Press selector switch (1) left/right, press switch (2) in direction of desired movement.

Tip: To lock mirrors in place, move selector to center position.

Power window switches

Ignition switch must be in ON position.

Front windows controlled from the driver's armrest; passenger door has a separate switch.

Driver's window

One-touch-down: Push down AUTO switch (3) firmly and release, window goes down all the way; pull switch back briefly to stop; press lightly and hold for normal operation.

Passenger window switch

Press button (4) down and hold to open; pull back and hold to close.

Power window lockout switch

Press button (5) down until it clicks, only driver's window operates; press again and passenger windows function again.

*Denotes optional equipment

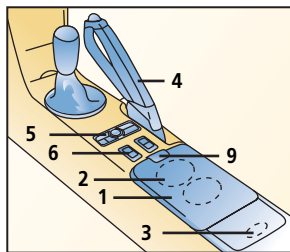

Front Console

1. Console

Press button (9) and slide cover rearward until it stops to access cup holders (2), then flip cover up to the right to access accessory socket (3).

2. Cup holders

3. Accessory socket

4. Parking-brake lever

To engage: Pull up.

To release: Pull up slightly while depressing button at front of lever, lower hand brake lever.

5. NAVI system remote control*

Press on/off switch; indicator light on when activated.

Tip: When activated, heated seats turn on when seat temperature is below approximately 80°F and turn off when seat temperature reaches approximately 100°F or above.

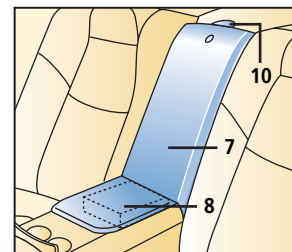

Rear Console

7. Storage

To open storage box: Squeeze latch (10) and pull lid downward.

Tip: Storage box can be removed to allow convenient loading of long objects through trunk.

See Owner's Manual for complete details and warnings.

8. NAVI DVD*

Always check the Owner's Manual for more operating information and safety features.

Console

HOMELINK®

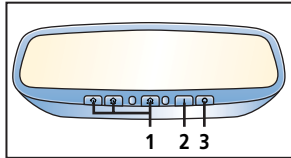

HomeLink® Wireless Control System*

Located on rear view mirror

To program or reprogram: Ignition must be off; hold transmitter for the device to be programmed between 1-3 inches to HomeLink®; press transmitter button and desired HomeLink® button (1) simultaneously until HomeLink® indicator light goes from slow to rapid flashing

Turn ignition on; verify device operation by pressing HomeLink® button (1) that was just programmed; repeat procedure for other buttons

Rolling code synchronization procedure

Refer to your garage door opener or device instruction manual to confirm your system is equipped with a rolling code feature

Tip: This procedure is easier done with the assistance of another person

To synchronize: Press programming button on garage door opener motor; press and release the programmed HomeLink® button 2 times within 30 seconds of pressing the garage door opening motor programming button

Some devices may require you to press and release a third time to complete programming procedure

Auto-dimming rear view mirror

Auto-dimming function changes are based on outside lighting conditions and if bright headlights are visible in rear view mirror Press on (2), off (3)

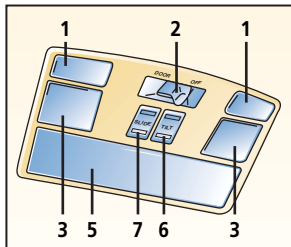

1. Map/reading light

Press on/off

2. Interior light switch

DOOR = light on when door open
ON = light always on
OFF = light always off

3. Front interior light

4. Rear interior light

5. Sunglass holder

Press concaved lip then open

6. Moonroof tilt switch*

Press rear of switch to tilt rear of sunroof

Press front of switch to close

7. Moonroof slide switch*

Press rear of switch to open sunroof

Press front of switch to close

Illuminated visor mirrors

Mirrors lighted when covers open; off when closed

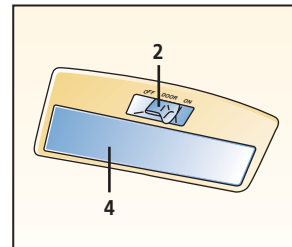

*Denotes optional equipment

Always check the Owner's Manual for more operating information and safety features

Interior Lights

TRANSMISSION

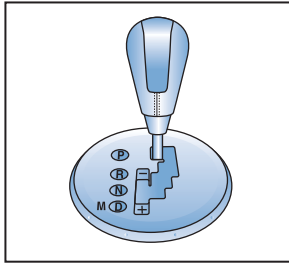
**Automatic transmission*****P = Park**

To move gearshift from Park: Press firmly on brake pedal, then move gearshift to gear selection

R = Reverse

N = Neutral No gear engaged

D (Overdrive)

For normal driving: Shifts through all forward gears automatically

**M (Sport A/T manual shift mode*)**

Move shifter from D to M to engage manual shift mode, M will be illuminated for manual mode on

shift position indicator located in the instrument panel

Manual shifting of transmission is achieved by moving shifter back to upshift and forward to downshift, move shifter from M to D to engage automatic shift mode

Gear indicator (A/T only)*

Illuminated numeral of gear indicator located in the instrument panel displays current gear in Automatic and Manual shift modes

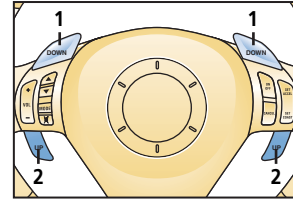
**Steering shift switches (A/T only)***

To upshift: Pull up switch (2)

To downshift: Press down switch (1)

Tip: Steering shift switches are marked UP and DOWN

WARNING: Placing shift lever in P position without setting parking brake may not hold vehicle, always set parking brake

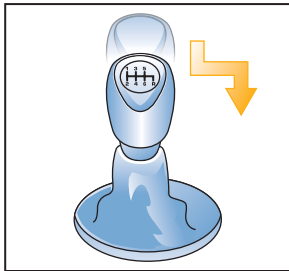
**Manual transmission***

Depress clutch pedal to start engine and change gears, push shifter downward when selecting reverse gear

WARNINGS: Do not shift into 1st above 20 mph or clutch failure could occur
Resting your foot on clutch pedal while driving and using the clutch to hold your vehicle at a stand still while waiting on a hill may reduce clutch life

*Denotes optional equipment

Always check the Owner's Manual for more operating information and safety features

Seats

SEATS

Manual controls

- 1. Fore-aft adjustment**
Lift lever and hold, slide seat, release lever
- 2. Raise/lower driver's seat**
Pull/push lever and release
- 3. Seatback angle**
To adjust: Lift and hold lever, lean forward or backward, release lever

 **Tip:** Pull up lever behind passenger's front seat to lower seatback for easy entry/exit from rear seat

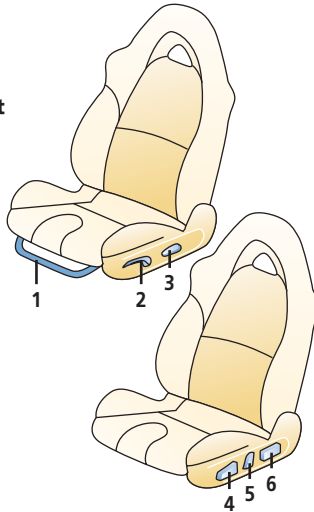

Power driver's seat*

- 4. Raise/lower front of seat cushion**
Pull/push front of switch vertically
- Fore/aft adjustment**
Slide switch horizontally
- Raise/lower rear of seat cushion**
Pull/push rear of switch vertically
- 5. Seatback angle**
Press front/rear of switch
- 6. Lumbar adjustment***
Press front/rear of switch to increase/decrease firmness

 **Tip:** Side-impact air bags deploy from outboard side of driver and front passenger seatbacks

Seat warmer*,
see Console

 **WARNINGS:** Do not adjust seats while driving
Safety belts must always be worn when vehicle is in motion
Air bags are supplemental and do not replace safety belt usage
Always wear your safety belt and properly secure children 12 and under in the rear seat
Never place rear-facing infant-safety seat in front of any air bag, an infant is in serious danger of being injured or killed
If you must install a forward-facing child-safety seat in the front seating position, move vehicle seat as far back as possible
Use age appropriate child restraints, see Owner's Manual and state or province laws

Child-safety seat

To install in rear outboard seats: Use dual locking mode retractor seat belts; see Owner's Manual for proper installation and child seat tether and LATCH system instructions

Passenger air bag deactivation indicator light

Front air bag deactivation indicator light provides current status of front passenger air bag and pretensioner system
If total seated weight on front passenger seat is less than approximately 66 lb., front passenger air bag deactivation indicator light illuminates, air bag/pretensioner will not deploy/activate in an accident
If the total seated weight is greater than approximately 93 lb., light does not illuminate, and the air bag/pretensioner will deploy/activate

in an appropriate accident, see Owner's Manual for additional information on this feature and the air bag system

Safety belt emergency locking mode

Belts lock only on hard acceleration, braking, cornering or impacts of about 5 mph or more

Automatic locking mode (front passenger and all rear safety belts only)

Must be used when installing child-safety seat

To activate: Pull webbing fully out of retractor until click is heard; belt will only tighten

To disengage: Unbuckle belt and allow webbing to retract fully

*Denotes optional equipment

Always check the Owner's Manual for more operating information and safety features

Seats

Climate Controls

CLIMATE CONTROLS

1. Air flow selections

- = air to dash
- = air to dash and floor
- = air to floor
- = air to floor and windshield

2. Fan control

Rotate knob between 0 (OFF) and 4 (HIGH)

3. Temperature control

Cooler/warmer = rotate knob counterclockwise/clockwise

4. A/C = air conditioner

Press to turn on/off

5. Air intake control

- = recirculate inside air; use for maximum cooling
- = fresh air

WARNING: Do not use position in cold weather, windows may fog and hamper vision

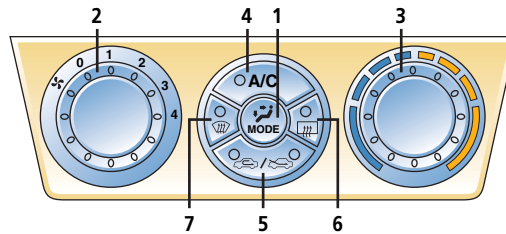

- 6. Rear window defogger**
Press on/off; shuts off with ignition; also operates heated side mirrors*

Control positions for maximum cooling

A/C ON, air to dash, recirculate, fan position 4 (HIGH)

Control positions for maximum defrost

Fan to maximum, temperature to maximum hot, selected

Tips: To help prevent windshield fogging in humid weather, select before starting engine. To prevent moisture buildup, never drive with system off. Objects placed under the front seats may interfere with air flow to the rear.

7. Front windshield defogger

A/C switches ON and air intake switches to fresh air

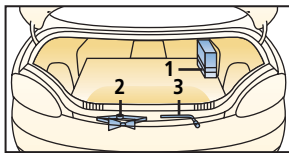

Trunk

To open: Use key, remote trunk-lid release, remote keyless entry fob or advanced keyless entry trunk request switch*

Remote trunk-lid release, see Driver's View

1. Instant Mobility System emergency flat tire repair kit (IMS)†, see Getting Started

2. Jack/jack handle

Lift cover to access jack/tools

3. Lug wrench

Tire economy and tips

Check tire pressure regularly when tires are cold, maintain correct front-end alignment and tire balance; rotate tires at the mileage shown in the Maintenance Guide; see Owner's Manual for rotation chart

Tire pressure

P225/55R16 94V,
P225/45R18 91W

Front/rear: 32psi cold

Tips: Correct tire pressure promotes proper handling and ride comfort

If you experience pull/drift while driving, possible causes may be road crown, tire pressure, or wheel alignment

The suspension is sport-tuned with firmer ride for optimum handling and response

Tire chains*†

Tire chains can damage aluminum wheels; use on steel wheels only

Tips: Use only SAE class "S" chains, install only on rear tires; install as tightly as possible and retighten after driving 1/4-1/2 mile; chains may affect handling. Never exceed 30 mph with tire chains



Luggage compartment internal safety release

Allows you to escape should you become locked in trunk. Slide illuminated release lever in direction of arrow; lever will glow if it has been exposed to light. Located on interior trunk lid

*Denotes optional equipment
† See Owner's Manual

Always check the Owner's Manual for more operating information and safety features

Trunk

Audio Systems

AM / FM STEREO / CASSETTE / CD

1. Power/Volume

Press to turn on/off; rotate to increase/decrease volume

 **Tip: Press (8) and (9) together to turn radio on**

2. Repeat

Press to replay current CD/ tape selection

3. Disc up \wedge †

Press to skip forward to beginning of next CD

4. Disc down \vee †

Press to skip back to beginning of previous CD

5. Tune/Auto-Memory

Tune: Rotate counterclockwise/ clockwise for lower frequency/ higher frequency
Radio: Press and hold until a beep sound is heard; system automatically scans and temporarily stores six strong stations in each band; press again to cancel

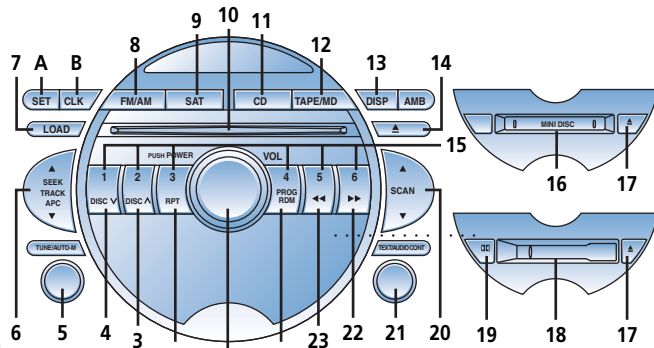

9. SAT*

Satellite ready capability
For additional information, see Owner's Manual

10. CD slot

21. Text/Audio Control

Audio control: Press to select BASS/MID/TREB/FADE/ BAL/BEEP ON/ALC OFF/ ALC LEVEL 1, 2, 3/AUDIO PLT ON**;
rotate right/left to adjust selected feature

6. SEEK/TRACK/APC

Radio: Press \blacktriangle / \blacktriangledown to automatically seek higher/lower frequency

CD: Press \blacktriangle / \blacktriangledown to select next/previous track

Tape: Press \blacktriangle / \blacktriangledown to automatically advance tape to beginning of next selection/ replay selection; to stop this operation, press button again

7. LOAD*

To load multiple discs: Press and hold LOAD (7) until beep sound is heard; insert CD when "In" is displayed

To eject disc: Press Eject (14)

To eject specific disc: Press and hold Eject (14) until beep sound is heard; within five seconds press the desired tray number 1-6 (15)

8. FM/AM

Press to select between FM1/FM2/ AM station preset buttons (15)

11. CD

Press to play CD

12. Tape*/MD*

Press to play Mini-disc Player/ cassette tape

13. DISP*

Press: Changes display during MD play

14. CD eject button

15. Memory preset buttons

To set: Tune to station, press and hold until beep sound is heard

16. Mini Disc slot*

17. Eject button*

18. Cassette door*

19. Dolby® Noise Reduction*

Reduces tape noise and hiss; press to activate/deactivate

20. Scan

Press to briefly sample next listenable selections; functions in all modes

 **Tip: Audio volume adjusts automatically depending on vehicle speed (Standard audio system) or noise (Bose audio system)**

22. Fast forward $\blacktriangleright\blacktriangleright$

Press to fast forward through a track

23. Reverse $\blacktriangleleft\blacktriangleleft$

Press to reverse through a track

24. Program Random†

Press to enable/cancel

Clock

To set: With ignition in ACC or ON position, press (B) and hold until beep sounds; 12 hr/24 hr will be displayed; press (A) to select; press (B) again while selection is flashing: Hr ADJUST displays; press (A) to select hr; press (B) when done, do the same to set minutes

* Denotes optional equipment

** Bose audio system only

† For use with cassette tape player, MD player, or CD changer*

Always check the Owner's Manual for more operating information and safety features

Audio Systems

Under Hood

UNDER HOOD

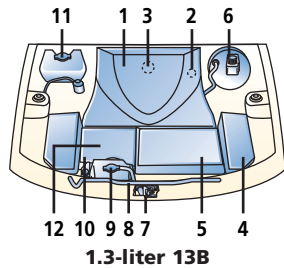

RX-8 rotary engine precautions

Check engine oil level when refueling. Rotary engine design uses an oil injection system in addition to lubrication of internal parts. It is important to maintain proper oil level.

*Denotes optional equipment
† See Owner's Manual

1. Engine cover

Remove to gain access to engine oil dipstick (2) and engine oil filler cap (3). To remove cover: Pull up firmly on front corners; then pull toward front of vehicle.

2. Engine oil dipstick

With engine cover (1) removed, check engine oil level 5 to 10 minutes after warming up engine; fluid level should be between full and low marks on dipstick.

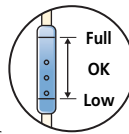

3. Engine oil filler cap

SAE 5W-20. Remove engine cover (1) to access engine oil filler cap.

4. Fuse block 5. Air filter

6. Brake/Clutch* fluid reservoir

Fill to MAX mark with DOT 3 fluid; check with cap on.

7. Hood latch

Push hood latch to the right, open hood.

8. Hood support rod

9. Engine coolant reservoir

Level should be between F and L lines when cold. **WARNING: Never remove coolant reserve tank cap while engine is running or hot; you could get burned.**

10. Battery

To access: Remove engine cover (1) first, then remove battery cover (12), pull up back of battery cover and remove.

11. Windshield washer reservoir

Fill with windshield washer fluid.

Break-in period

First 600 miles: Drive at varying road and engine speeds; avoid full throttle, rapid acceleration or kick-down of transmission. Do not use special "break-in" oils.

Anti-lock Braking System (ABS)

ABS automatically reduces hydraulic pressure to any wheel on the verge of locking up. You may feel a slight pulsing of the brake pedal and hear a clicking noise; this tells you the ABS is functioning properly; increase pressure on pedal for maximum braking.

Tips: Maintain constant pressure on the brake pedal. Do not pump the brakes.

ABS self test

A self-diagnostic test is performed when starting; you may feel some brake pedal pulsation and hear some noise, this is normal.

NORMAL SERVICE INTERVALS

7,500 miles	A
15,000 miles	A B E
22,500 miles	A
30,000 miles	A B C E
37,500 miles	A D
45,000 miles	A B
52,500 miles	A E
60,000 miles	A B C F
67,500 miles	A
75,000 miles	A
82,500 miles	A
90,000 miles	A

Unique driving conditions†

Every 5,000 miles change oil/filter, inspect coolant level, lights, brake/clutch fluid, tire pressure/wear, locks/hinges and washer fluid.

Normal maintenance notes

Rotate tires every 7,500 miles or sooner if needed; replace cabin air filter every 25,000 miles or 24 months. Replace (FL22)* engine coolant every 120,000 miles or 10 years.

A. Change: Engine oil/replace filter
Lube: Locks and hinges

B. Inspect: Disc brakes

C. Inspect: Drive belt, fuel lines, hoses, and connections, brake lines and hoses, steering operation and linkages, front and rear suspension ball joints, driveshaft dust boots, chassis and body bolts, exhaust system heat shields, cooling system, and bolts and nuts on seat

D. Replace: Air filter, spark plugs

E. Clean: Air filter

F. Replace: Manual transmission and rear differential oil, engine coolant

Always check the Owner's Manual for more operating information and safety features