

FAX-1860C

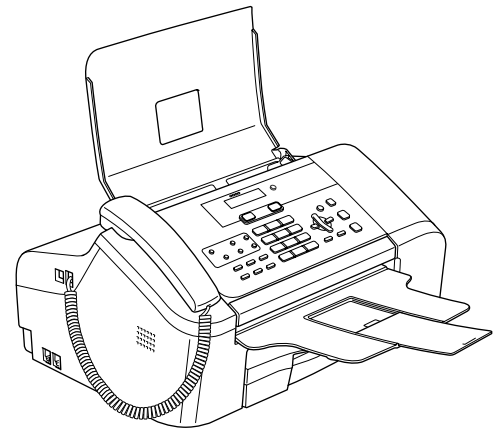





Before you can use the machine, you must set up the hardware.
Please read this Quick Setup Guide for the correct setup procedure.

Setting Up the Machine

Setup is Complete!

Keep this Quick Setup Guide and the User's Guide in a convenient place for quick and easy reference at all times.







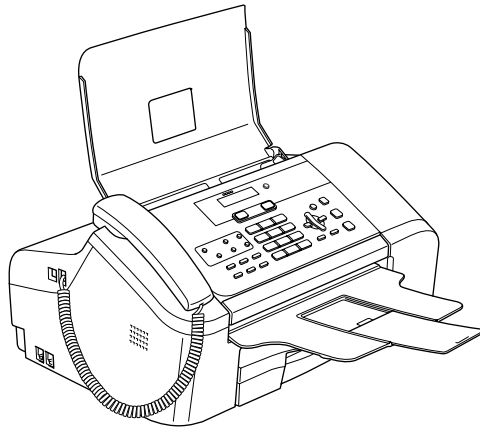

Symbols used in this guide

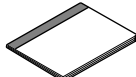
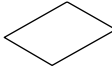
 Warning	 Caution	 Improper Setup
Warnings tell you what to do to prevent possible personal injury.	Cautions specify procedures you must follow or avoid to prevent possible damage to the machine or other objects.	Improper Setup icons alert you to devices and operations that are not compatible with the machine.
 Note	 User's Guide	
Notes tell you how you should respond to a situation that may arise or give tips about how the current operation works with other features.	Indicates reference to the User's Guide we have supplied.	

Carton components

Carton components may vary from one country to another.
Save all packing materials and the carton in case for any reason you must ship your machine.

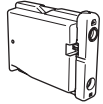
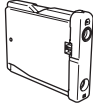

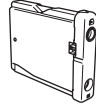
 Quick Setup Guide	 User's Guide	 Accessory Order Form	 Handset Curled Cord
 Telephone Handset	 Telephone Line Cord	 One Touch Labels	 Test Sheet
 Black (LC51BK)	 Yellow (LC51Y)	 Cyan (LC51C)	 Magenta (LC51M)
Ink Cartridges			

Control panel

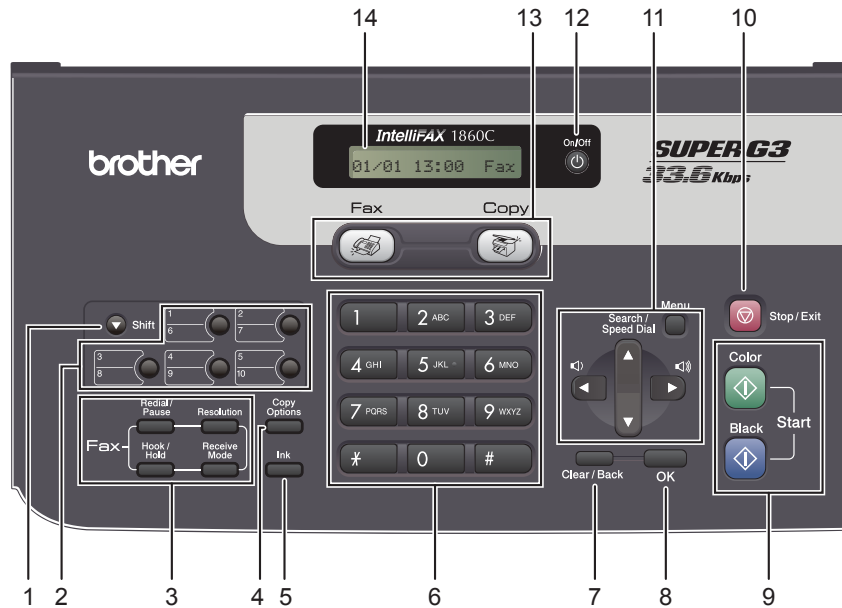

- | | |
|--------------------------|---------------------------------|
| 1 Shift | 8 OK key |
| 2 One Touch keys | 9 Start keys |
| 3 Fax and telephone keys | 10 Stop/Exit key |
| 4 Copy Options key | 11 Menu keys |
| 5 Ink key | 12 On/Off key |
| 6 Dial Pad | 13 Mode keys |
| 7 Clear/Back key | 14 LCD (Liquid Crystal Display) |



For the details of the control panel, see Control panel overview in Chapter 1 of the User's Guide.



Note

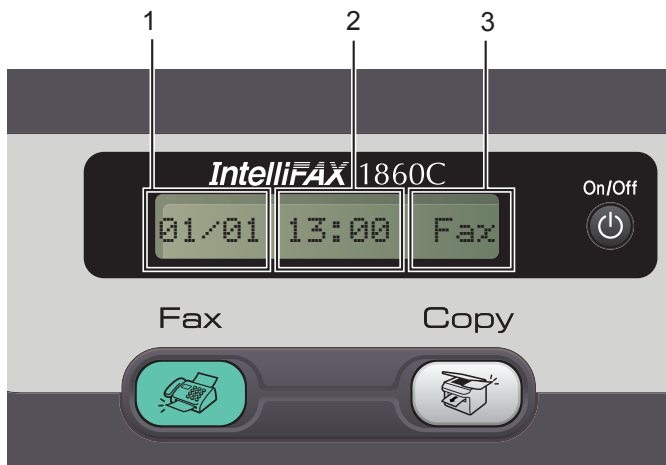

- 1 Date
- 2 Time
- 3 Receive mode

When the machine is idle (not being used) it will return to the default display shown above. The default display shows the date, time, and the current receive mode.

1 Removing the protective parts

- 1 Remove the protective tape.
- 2 Remove the foam bag containing the ink cartridges from on top of the paper tray.

2 Installing the Handset

- 1 Connect the curled handset cord to the machine and the other end to the handset.

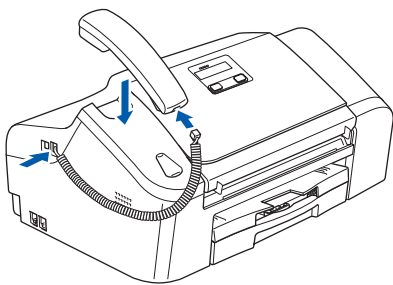

3 Opening the document support and document tray

- 1 Open the document support (①) and the document tray (②) and then pull out the extension (③).

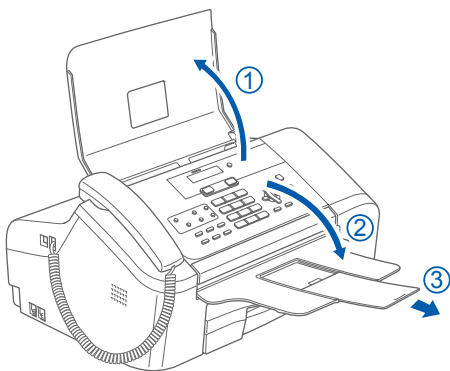

4 Loading paper

-  You can load up to 100 sheets of 20 lb (80 g/m²) paper.
For details, see *Acceptable paper and other media* in Chapter 2 of the User's Guide.

- 1 Pull the paper tray completely out of the machine. If the paper support flap (1) is open, close it. Open the output paper tray cover (2).

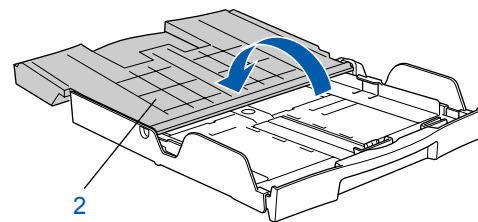
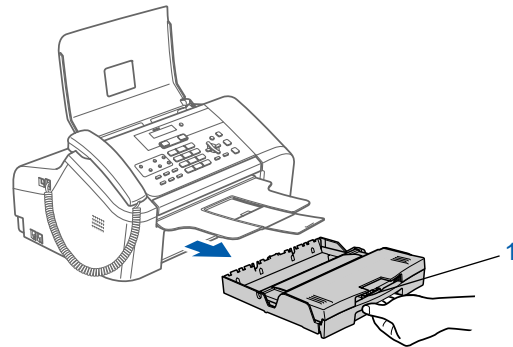

- 2 If you are using Letter, A4 or Legal size paper, press and hold universal guide release button (1) as you slide out the front of the paper tray to match the paper size you are using.

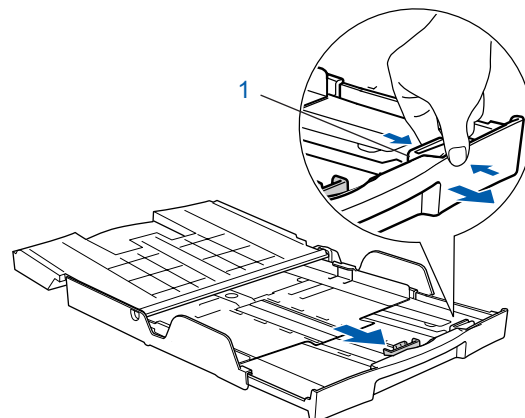

- 3 Press and slide the paper side guides (1) and paper length guide (2) to fit the paper size.

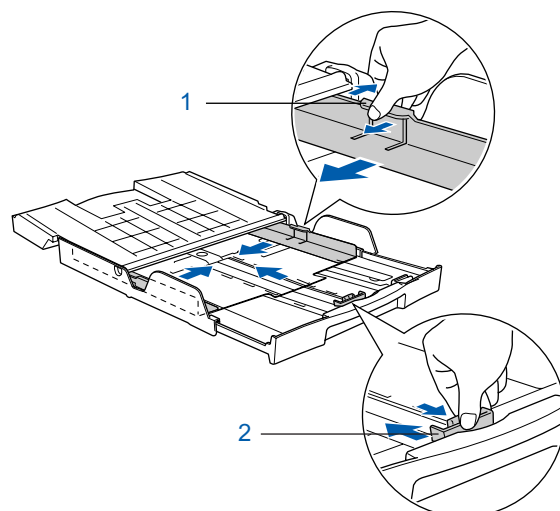

Setting Up the Machine

- 4** Fan the stack of paper well to avoid paper jams and misfeeds.

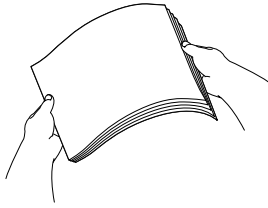

- 5** Gently put the paper into the paper tray print side down and top edge first. Check that the paper is flat in the tray.

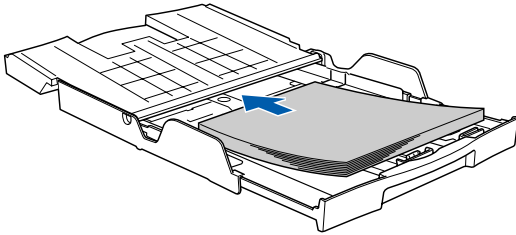

- 6** Gently adjust the paper side guides with both hands and the paper length guide to fit the paper. Make sure that the paper side guides and paper length guide touch the edges of the paper.

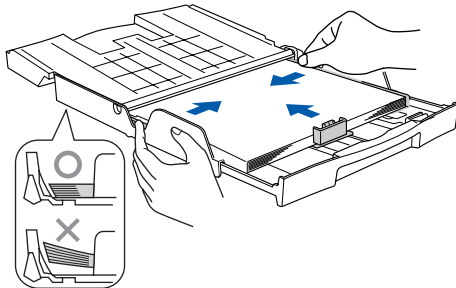

 **Note**

Be careful that you do not push the paper in too far; it may lift at the back of the tray and cause paper feed problems.

- 7** Close the output paper tray cover (1) and slide it forward.

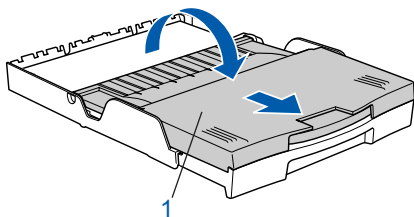

 **Note**

If you are using Legal size paper the paper tray cover does not slide all the way to the end of the paper tray.

- 8** Slowly push the paper tray completely into the machine.

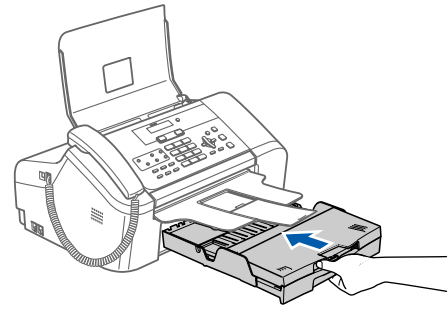

- 9** While holding the paper tray in place, pull out the paper support (1) until it clicks and unfold the paper support flap (2).

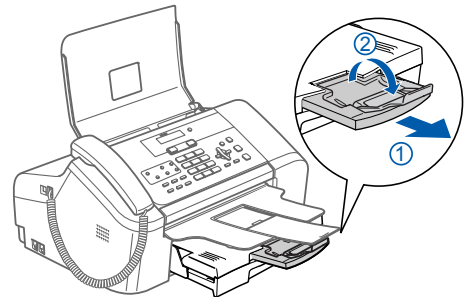

 **Note**

Do not use the paper support flap for Legal paper.

5 Connecting the phone line

- 1** Connect the telephone line cord. Connect one end of the telephone line cord to the jack on the machine marked **LINE** and the other end to a modular wall jack.

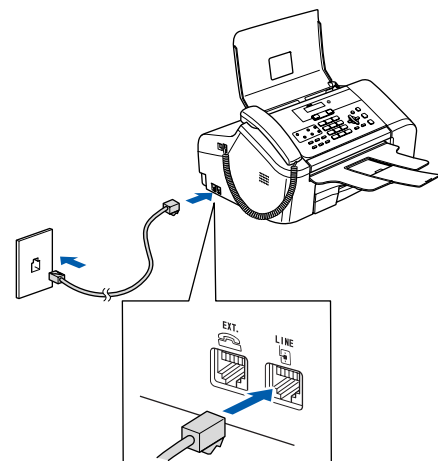

Note

If you are sharing one phone line with an external telephone, connect it as shown below.

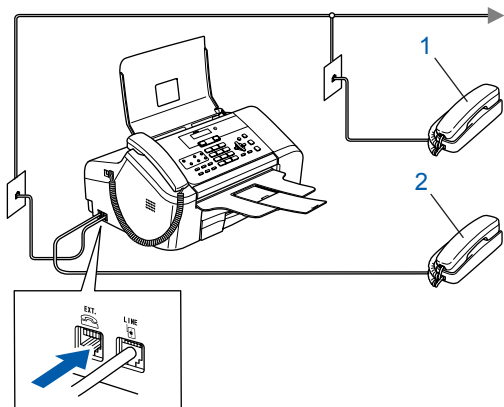

- 1 Extension telephone
- 2 External telephone

Note

If you are sharing one phone line with an external telephone answering machine, connect it as shown below.

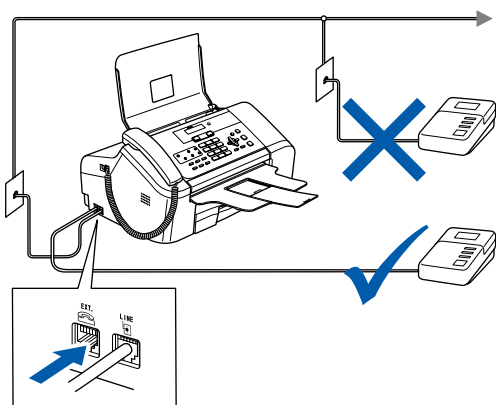

Set the receive mode to 'External TAD' if you have an external answering machine. For details, see *Connecting an external TAD (telephone answering device)* in Chapter 7 of the User's Guide.

6 Connecting the power cord

- 1 Connect the power cord.

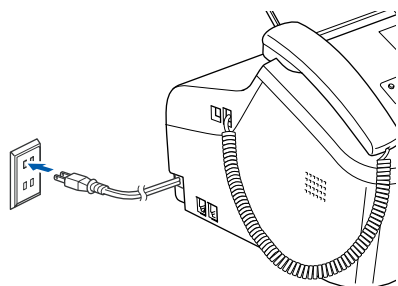

7 Installing the ink cartridges

Warning

If ink gets in your eyes, wash them out with water at once, and if irritation occurs consult a doctor.

- 1 Make sure that the power is turned on. The LCD shows:

No Cartridge

- 2 Open the ink cartridge cover (1).



- 3 Pull all the lock release levers down and remove the yellow protective part (1).

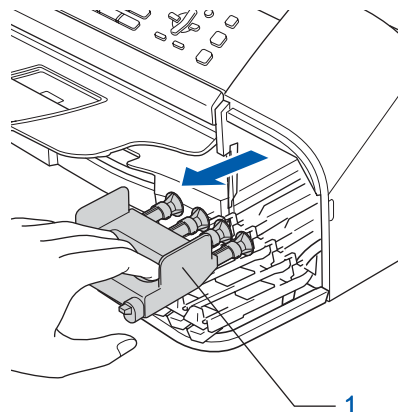
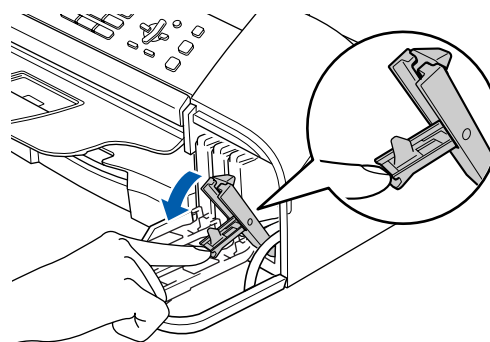

Note

Do not throw away the yellow protective part. You will need it if you transport the machine.

Setting Up the Machine

- 4** Take out the ink cartridge.

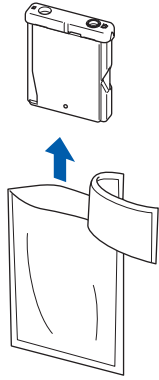

- 5** Carefully remove the protective yellow cap (1).

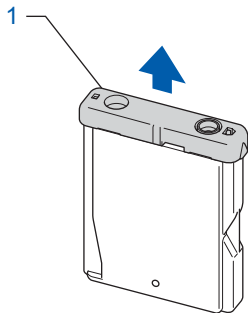

⊘ Improper Setup

DO NOT touch the area shown in the illustration below.

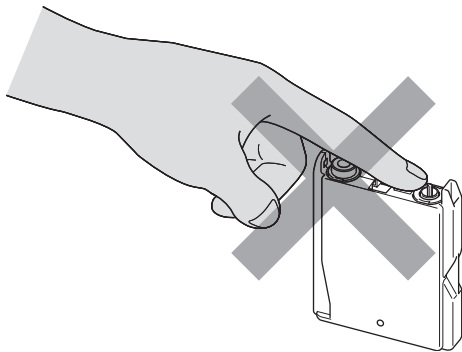

📝 Note

If the protective yellow cap comes off when you open the bag, the cartridge will not be damaged.

- 6** Install each ink cartridge in the direction of the arrow on the label. Take care to match the color of the lock release lever (1) with the cartridge color (2), as shown in the diagram below.

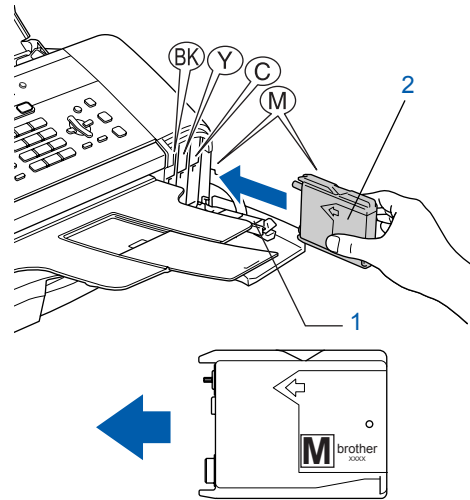

- 7** Lift each lock release lever and gently push until it clicks, and then close the ink cartridge cover.

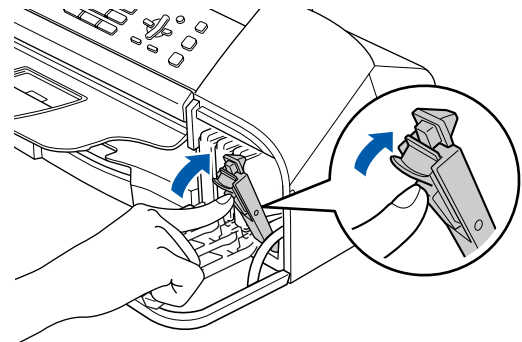

📝 Note

*If the LCD shows **Install Black**, **Install Yellow**, **Install Cyan** or **Install Magenta** after you install the ink cartridges, check that the ink cartridges are installed properly.*

The machine will clean the ink tube system for use for the first time. This process will occur only once, the first time ink cartridges are installed. The cleaning process will last approximately four minutes.

The LCD shows:

Preparing System



Approx 4 Minutes

Cleaning



Please Wait

! Caution

- DO NOT take out ink cartridges if you do not need to replace them. If you do so, it may reduce the ink quantity and the machine will not know the quantity of ink left in the cartridge.
- DO NOT shake the ink cartridges. If ink stains your skin or clothing, wash with soap or detergent at once.
- DO NOT repeatedly insert and remove the cartridges. If you do so, ink may seep out of the cartridge.
- If you mix the colors by installing an ink cartridge in the wrong position, clean the print head several times after correcting the cartridge installation. (See *Cleaning the print head in Appendixes B of the User's Guide.*)
- Once you open an ink cartridge, install it in the machine and use it up within six months of installation. Use unopened ink cartridges by the expiration date written on the cartridge package.
- DO NOT dismantle or tamper with the ink cartridge, this can cause the ink to leak out of the cartridge.
- Brother strongly recommends that you do not refill the ink cartridges provided with your machine. We also strongly recommend that you continue to use only Genuine Brother Brand replacement ink cartridges. Using or attempting to use potentially incompatible inks and /or cartridges in your machine may cause damage to the machine itself and/or it may result in unsatisfactory print quality. Our warranty coverage does not apply to any problem that was caused by the use of unauthorized third party ink and/or cartridges. To protect your investment and guarantee your print quality please continue to replace consumed ink cartridges with only Genuine Brother Branded Supplies.

8 Print quality check

- 1 After the cleaning cycle is finished, the LCD shows:

Set Paper and



Press Start

- 2 Make sure paper is loaded in the paper tray. Press **Color Start**. The machine starts printing the Print Quality Check Sheet (only during initial ink cartridge installation).

- 3 Check the quality of the four color blocks on the sheet.
(black/ yellow/ cyan/ magenta)

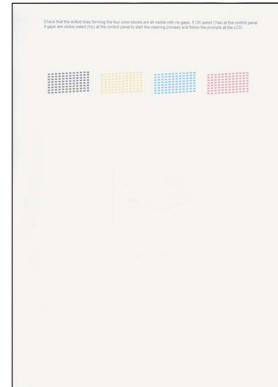

⊘ Improper Setup

Avoid touching the printed surface of the paper immediately after printing, the surface may not be completely dry and may stain your fingers.

- 4 The LCD shows:

Is Quality OK?



1.Yes 2.No

Setting Up the Machine

5

Do one of the following:

- If all lines are clear and visible, press 1 (Yes) on the dial pad to finish the quality check.
- If you can see missing short lines, press 2 (No) on the dial pad and go to step 6.

OK



Poor

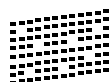

6

The LCD asks you if the print quality is OK for black and color. Press 1 (Yes) or 2 (No) on the dial pad.

Black OK?



1.Yes 2.No

Color OK?



1.Yes 2.No

After pressing 1 (Yes) or 2 (No) for both black and color, the LCD shows:

Start Cleaning?



1.Yes 2.No

7

Press 1 (Yes), the machine will then start cleaning the colors.

8

After cleaning is finished, press **Color Start**. The machine starts printing the Print Quality Check Sheet again and goes back to step 3.

9

Setting the LCD contrast

You can adjust the LCD contrast for a sharper and more vivid display. If you are having difficulty seeing the LCD from your position, we recommend the following contrast setting for improved viewing.

1

Press **Menu**, 1, 7.

2

Press ▲ or ▼ to choose **Dark** or **Light**.

3

Press **OK**.

4

Press **Stop/Exit**.

Contrast:Light



Contrast:Dark

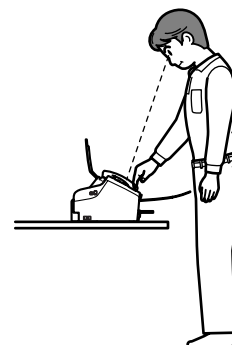

10 Setting the date and time

The machine displays the date and time, and if you set up the station ID it will add it to each fax you send.

1 Press **Menu, 0, 1**.

2 Enter the last two digits of the year on the dial pad, and then press **OK**.

Year: 2007

(e.g. Enter **0 7** for 2007.)

3 Enter the two digits for the month on the dial pad, and then press **OK**.

Month: 03

(e.g. Enter **0 3** for March.)

4 Enter the two digits for the day on the dial pad, and then press **OK**.

Day: 01

(e.g. Enter **0 1** for the first day of the month.)

5 Enter the time in 24-hour format on the dial pad, and then press **OK**.

Time: 15:25

(e.g. Enter **1 5, 2 5** for 3:25 P.M.)

6 Press **Stop/Exit**.



To confirm the current date and time, print out the Users Settings Report. See Printing Reports in the User's Guide.

11 Setting your station ID

You should store your name and fax number to be printed on all fax pages that you send.

1 Press **Menu, 0, 2**.

2 Enter your fax number (up to 20 digits) on the dial pad, and then press **OK**.

Fax: _

3 Enter your name (up to 20 characters) using the dial pad, and then press **OK**.

Name: _



Note

- See the following chart for entering your name.
- If you need to enter a character that is on the same key as the last character, press to move the cursor to the right.
- If you entered a letter incorrectly and want to change it, press or to move the cursor under the incorrect character, press **Clear/Back**.

Press key	One time	Two times	Three times	Four times
2	A	B	C	2
3	D	E	F	3
4	G	H	I	4
5	J	K	L	5
6	M	N	O	6
7	P	Q	R	S
8	T	U	V	8
9	W	X	Y	Z

4 Press **Stop/Exit**.



Note

If you want to repeat input, press **Stop/Exit** to start from step 1.



For details, see Entering Text in Appendix C of the User's Guide.

Note

The Telephone Consumer Protection Act of 1991 makes it unlawful for any person to use a computer or electronic device to send any message via a telephone fax machine unless such messages clearly contain, in a margin at the top or bottom of each transmitted page, or on the first page of the transmission, the date and time it is sent and an identification of the business or other entity or other individual sending the message and the telephone number of the sending machines or such business, other entity or individual. To program this information into your machine, see *Setting the date and time* on page 9 and *Setting your station ID* on page 9.

12 Setting tone or pulse dialing mode

Your machine comes set for Tone dialing service. If you have Pulse dialing service (rotary), you need to change the dialing mode.

- 1 Press **Menu**, **0**, **3**.
- 2 Press **▲** or **▼** to choose **Pulse** (or **Tone**). Press **OK**.
- 3 Press **Stop/Exit**.

13 Choosing a Receive Mode

There are four possible receive modes: **Fax Only**, **Fax/Tel**, **Manual** and **External TAD**.

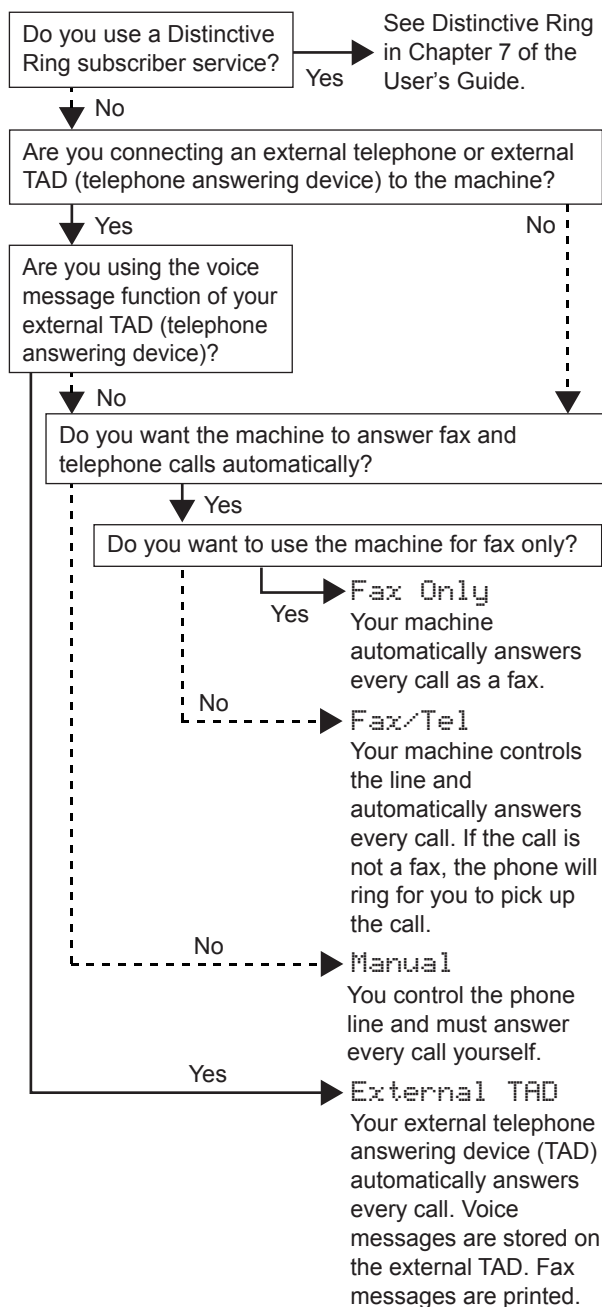

- 1 Press **Receive Mode**.
- 2 Press **▲** or **▼** to choose the mode.
- 3 Press **OK**.
- 4 Press **Stop/Exit**.



For details, see *Using receive modes* in Chapter 6 of the User's Guide.

14 Sending in the Product Registration and Test Sheet

- 1 Fill out the Product Registration and Test Sheet.

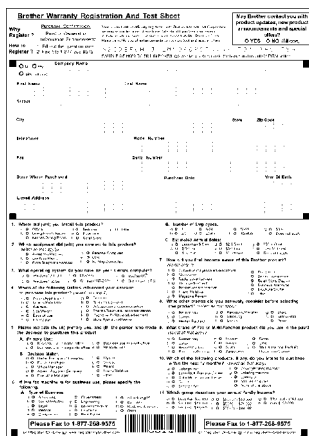

- 2 Put the sheet face down in the ADF (Automatic Document Feeder).

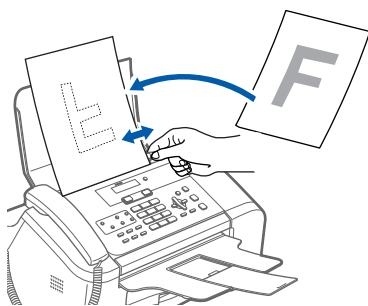

- 3 Make sure  (Fax) is illuminated in Green.
- 4 Enter the toll-free fax number: 1-877-268-9575.
- 5 Press **Black**.

Note
 You will receive a confirmation fax of your Product Registration.
 You can also register your product online using the On-Line Registration link (visit <http://www.brother.com/registration>).

15 Using the Fax as a printer or for PC-Fax send

You can download the Brother printer driver and PC-Fax send driver from the Brother Solutions Center for use with FAX-1860C.

Vist us at: <http://solutions.brother.com>

Follow install instructions on the Driver download page.

Note

- Please download the printer driver first before connecting the machine to your computer with a USB cable.
- You must use an appropriate USB 2.0 interface cable. If you do not have it, please purchase a USB 2.0 interface cable that is no longer than 6 feet long (2 meters).

Note

Connecting the USB cable

- 1 Insert the USB cable into the USB port marked with a  symbol. You will find the USB port next to the handset cord port as shown below.

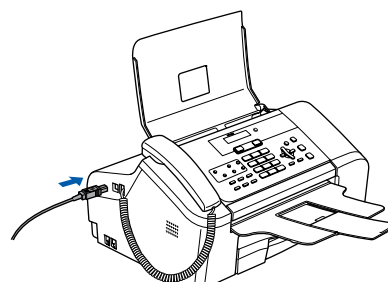

- 2 Connect the USB cable to your computer.

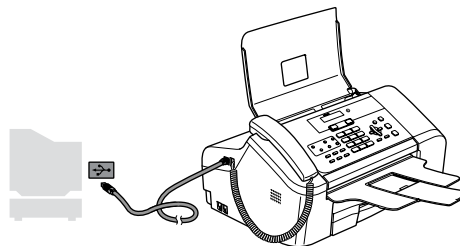



Improper Setup

DO NOT connect the machine to a USB port on a keyboard or a non-powered USB hub. Brother recommends that you connect the machine directly to your computer.

Replacement consumables

When the time comes to replace ink cartridges, an error message will be indicated on the LCD. For more information about the ink cartridges for your machine, visit <http://solutions.brother.com> or contact your local Brother re-seller.

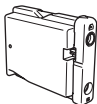
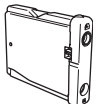
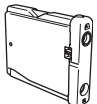
Ink cartridge

Black	Yellow	Cyan	Magenta
LC51BK	LC51Y	LC51C	LC51M
			

Trademarks

The Brother logo is a registered trademark of Brother Industries, Ltd.

Brother is a registered trademark of Brother Industries, Ltd.

Windows and Microsoft are registered trademarks of Microsoft in the U.S. and other countries.

Macintosh is registered trademark of Apple Computer, Inc.

All other brand and product names mentioned in this manual are trademarks or registered trademarks of their respective companies.

Compilation and Publication

Under the supervision of Brother Industries Ltd., this manual has been compiled and published, covering the latest product descriptions and specifications.

The contents of this manual and the specifications of this product are subject to change without notice.

Brother reserves the right to make changes without notice in the specifications and materials contained herein and shall not be responsible for any damages (including consequential) caused by reliance on the materials presented, including but not limited to typographical and other errors relating to the publication.

This product is designed for use in a Professional Environment.

Copyright and License

©2006 Brother Industries, Ltd.

brother®

USA