



Multi-Protocol On-board Ethernet Multi-function Print Server and
Wireless (IEEE 802.11b/g) Ethernet Multi-function Print Server

NETWORK USER'S GUIDE

Please read this manual thoroughly before using this machine on your network. You can print or view this manual from the CD-ROM at any time, please keep the CD-ROM in a convenient place for quick and easy reference at all times.

The Brother Solutions Center (<http://solutions.brother.com>) is your one stop resource for all your printing needs. Download the latest drivers and utilities for your machine, read FAQs and troubleshooting tips or learn about special printing solutions.

Definitions of warnings, cautions, and notes

We use the following icon throughout this User's Guide:



Notes tell you how you should respond to a situation that may arise or give tips about how the operation works with other features.

Trademarks

Brother and the Brother logo are registered trademarks and BRAdmin Professional is a trademark of Brother Industries, Ltd.

UNIX is a registered trademark of The Open Group.

Apple and Macintosh are registered trademarks of Apple Inc.

Microsoft and Windows are registered trademarks of Microsoft Corporation.

Windows Vista is either a registered trademark or trademark of Microsoft Corporation in the United States and / or other countries.

BROADCOM, SecureEasySetup and the SecureEasySetup logo are trademarks or registered trademarks of Broadcom Corporation.

AOSS is a trademark of Buffalo Inc.

Wi-Fi is a registered trademark and WPA and WPA2 are registered trademarks of the Wi-Fi Alliance.

Firefox is a registered trademark of the Mozilla Foundation.

All other terms, brand and product names mentioned in this User's Guide are registered trademarks or trademarks of their respective companies.

Copyright and License

Part of the software embedded in this product is gSOAP software.

Portions created by gSOAP are Copyright (C) 2001–2004 Robert A. van Engelen, Genivia inc.
All Rights Reserved.

THE SOFTWARE IN THIS PRODUCT WAS IN PART PROVIDED BY GENIVIA INC AND ANY EXPRESS OR IMPLIED WARRANTIES, INCLUDING, BUT NOT LIMITED TO, THE IMPLIED WARRANTIES OF MERCHANTABILITY AND FITNESS FOR A PARTICULAR PURPOSE ARE DISCLAIMED. IN NO EVENT SHALL THE AUTHOR BE LIABLE FOR ANY DIRECT, INDIRECT, INCIDENTAL, SPECIAL, EXEMPLARY, OR CONSEQUENTIAL DAMAGES (INCLUDING, BUT NOT LIMITED TO, PROCUREMENT OF SUBSTITUTE GOODS OR SERVICES; LOSS OF USE, DATA, OR PROFITS; OR BUSINESS INTERRUPTION) HOWEVER CAUSED AND ON ANY THEORY OF LIABILITY, WHETHER IN CONTRACT, STRICT LIABILITY, OR TORT (INCLUDING NEGLIGENCE OR OTHERWISE) ARISING IN ANYWAY OUT OF THE USE OF THIS SOFTWARE, EVEN IF ADVISED OF THE POSSIBILITY OF SUCH DAMAGE.

Compilation and publication notice

Under the supervision of Brother Industries Ltd., this manual has been compiled and published, covering the latest product's descriptions and specifications.

The contents of this manual and the specifications of this product are subject to change without notice.

Brother reserves the right to make changes without notice in the specifications and materials contained herein and shall not be responsible for any damages (including consequential) caused by reliance on the materials presented, including but not limited to typographical and other errors relating to the publication.

©2007 Brother Industries Ltd.

IMPORTANT NOTE

- This product is approved for use in the country of purchase only. Do not use this product outside the country of purchase as it may violate the wireless telecommunication and power regulations of that country.
- Windows® XP in this document represents Windows® XP Professional, Windows® XP Professional x64 Edition and Windows® XP Home Edition.

Brother numbers

IMPORTANT

For technical and operational assistance, you must call the country where you purchased the machine. Calls must be made **from within** that country.

For Customer Service

In USA 1-800-284-4329
In Canada 1-877-BROTHER
In Europe Visit <http://www.brother.com> for contact information on your local Brother office.

■ Service center locator (USA)

For the location of a Brother authorized service center, call 1-800-284-4357.

■ Service center locations (Canada)

For the location of a Brother authorized service center, call 1-877-BROTHER.

If you have any comments or suggestions, please write to us at:

| | |
|------------------|---|
| In USA | Customer Support Brother International Corporation 100 Somerset Corporate Boulevard Bridgewater NJ 08807-0911 |
| In Canada | Brother International Corporation (Canada), Ltd. - Marketing Dept. 1, rue Hôtel de Ville Dollard-des-Ormeaux, PQ, Canada H9B 3H6 |
| In Europe | European Product & Service Support 1 Tame Street Audenshaw Manchester, M34 5JE, UK |

Internet address

Brother Global Web Site: <http://www.brother.com>

For Frequently Asked Questions (FAQs), Product Support, Driver Updates and Utilities:
<http://www.brother.com>

(In USA Only) For Brother Accessories & Supplies: <http://www.brothermall.com>

Brother fax-back system (USA)

Brother has set up an easy-to-use fax-back system so you can get instant answers to common technical questions and information about all our products. This is available 24 hours a day, seven days a week. You can use the system to send the information to any fax machine.

Call the number below and follow the recorded instructions to receive a fax about how to use the system and an Index of the subjects you can get information about.

In USA only

1-800-521-2846

Table of Contents

| | | |
|----------|--|-----------|
| 1 | Introduction | 1 |
| | Overview..... | 1 |
| | Network features..... | 2 |
| | Network printing..... | 2 |
| | Network scanning..... | 2 |
| | Network PC-FAX (Not available for DCP models)..... | 2 |
| | Network PhotoCapture Center™..... | 2 |
| | Management utilities..... | 2 |
| | Types of Network Connections..... | 4 |
| | Network Connection Example..... | 4 |
| | Wireless network connection example..... | 6 |
| | Protocols..... | 8 |
| | TCP/IP protocols and functions..... | 8 |
| 2 | Configuring your machine for a network with an Ethernet cable connection | 10 |
| | Overview..... | 10 |
| | IP addresses, subnet masks and gateways..... | 10 |
| | IP address..... | 10 |
| | Subnet mask..... | 11 |
| | Gateway (and router)..... | 11 |
| | Setting up the IP address and subnet mask..... | 12 |
| | Using the BRAdmin Light utility to configure your machine for the network printer..... | 12 |
| | Using the control panel to configure your machine for a network..... | 14 |
| | Using other methods to configure your machine for a network..... | 14 |
| | Changing the print server settings..... | 15 |
| | Using the BRAdmin Light utility to change the print server settings..... | 15 |
| | Using the control panel to change the print server settings..... | 15 |
| | Using the Remote Setup to change the print server settings (Not available for DCP models)..... | 16 |
| | Remote Setup for Windows®..... | 16 |
| | Remote Setup for Macintosh®..... | 16 |
| 3 | Configuring your machine for a wireless network | 17 |
| | Overview..... | 17 |
| | Confirm your network environment..... | 17 |
| | Wireless network connection example..... | 17 |
| | Confirm your network environment..... | 19 |
| | Wireless network terms and concepts..... | 20 |
| | SSID (Service Set Identifier) and channels..... | 20 |
| | Authentication and encryption..... | 20 |
| | Configuring your machine for a wireless network..... | 22 |
| | Using the Setup Wizard from the control panel..... | 22 |
| | Using the SecureEasySetup™ or AOSS™ software to configure your machine for a wireless network..... | 24 |
| | Using the Brother automatic installer application on the CD-ROM to configure your machine for a wireless network..... | 25 |
| | Changing the print server settings..... | 26 |

| | | |
|----------|--|------------|
| | Using the BRAdmin Professional utility to change the wireless settings (for Windows®)..... | 26 |
| | Using the control panel to change the print server settings..... | 27 |
| | Using other methods to configure your machine for a wireless network | 27 |
| | Using the Remote Setup to change the print server settings (Not available for DCP models)..... | 28 |
| 4 | Wireless Configuration for Windows® | 29 |
| | Configuration in Infrastructure mode | 29 |
| | For Windows® 2000 Professional/XP or Windows Vista™ | 29 |
| | Configuration with an access point that supports SecureEasySetup™ or AOSS™ | 41 |
| | For Windows® 2000/XP or Windows Vista™ | 41 |
| | Configuration in Ad-hoc Mode | 47 |
| | For Windows® 2000 Professional/XP or Windows Vista™ | 47 |
| 5 | Wireless Configuration for Macintosh® | 57 |
| | Configuration in Infrastructure mode | 57 |
| | For Mac OS®X 10.2.4 or greater | 57 |
| | Configuration with an access point that supports SecureEasySetup™ or AOSS™ | 68 |
| | For Mac OS®X 10.2.4 or greater | 68 |
| | Configuration in Ad-hoc Mode | 73 |
| | For Mac OS®X 10.2.4 or greater | 73 |
| 6 | Control panel setup | 82 |
| | LAN menu..... | 82 |
| | Wired LAN TCP/IP / WLAN TCP/IP..... | 82 |
| | Setup Wizard (for wireless network only) | 90 |
| | SecureEasySetup (for wireless network only)..... | 90 |
| | AOSS (for wireless network only)..... | 90 |
| | WLAN Status (for wireless network only) | 90 |
| | Ethernet (for wired network only)..... | 92 |
| | Network I/F | 93 |
| | Printing the Network Configuration List | 93 |
| | Restoring the network settings to factory default..... | 94 |
| 7 | Driver Deployment Wizard (Windows® only) | 95 |
| | Overview..... | 95 |
| | Connection methods..... | 95 |
| | Peer-to-Peer | 95 |
| | Network Shared Printer | 96 |
| | How to install the Driver Deployment Wizard software..... | 97 |
| | Using the Driver Deployment Wizard software..... | 98 |
| 8 | Network printing from Windows® basic TCP/IP Peer-to-Peer printing | 100 |
| | Overview..... | 100 |
| | For Windows® 2000/XP and Windows Vista™ users | 100 |
| | Configuring the standard TCP/IP port | 100 |
| | Other sources of information | 101 |

| | | |
|-----------|--|------------|
| 9 | Network printing from a Macintosh® | 102 |
| | Overview..... | 102 |
| | How to select the print server (TCP/IP)..... | 102 |
| | Changing the print server settings..... | 104 |
| | Changing the configuration using the Remote Setup (Not available for DCP models)..... | 104 |
| | Using the BRAdmin Light utility to change the print server settings..... | 104 |
| | Other sources of information..... | 104 |
| 10 | Troubleshooting | 105 |
| | Overview..... | 105 |
| | General problems..... | 105 |
| | Network print software installation problems..... | 106 |
| | Printing problems..... | 108 |
| | Scanning and PC Fax problems..... | 109 |
| | Wireless network troubleshooting..... | 111 |
| | Wireless setup problems..... | 111 |
| | Wireless connection problem..... | 111 |
| A | Appendix A | 112 |
| | Using services..... | 112 |
| | Other ways to set the IP address (for advanced users and administrators)..... | 112 |
| | Using DHCP to configure the IP address..... | 112 |
| | Using BOOTP to configure the IP address..... | 112 |
| | Using RARP to configure the IP address..... | 113 |
| | Using APIPA to configure the IP address..... | 114 |
| | Using ARP to configure the IP address..... | 114 |
| | Using the TELNET console to configure the IP address..... | 115 |
| | Installation when using a Network Print Queue or Share (printer driver only)..... | 116 |
| | Installation when using Web Services (For Windows Vista™ users)..... | 117 |
| B | Appendix B | 118 |
| | Print server specifications..... | 118 |
| | Ethernet wired network..... | 118 |
| | Ethernet wireless network..... | 120 |
| | Function table and default factory settings..... | 122 |
| | Entering Text..... | 125 |
| | For MFC models..... | 125 |
| | For DCP models..... | 126 |
| C | Index | 127 |

Overview

The Brother machine can be shared on a 10/100 MB wired or IEEE 802.11b/802.11g wireless Ethernet network using the internal network print server. The print server supports various functions and methods of connection depending on the operating system you are running on a network supporting TCP/IP. These functions include printing, scanning, PC-FAX send, PC-FAX receive, PhotoCapture Center™, Remote Setup and Status Monitor. The following chart shows what network features and connections are supported by each operating system.

| Operating Systems | 10/100 BASE-TX Wired Ethernet (TCP/IP) | IEEE 802.11b/g Wireless Ethernet (TCP/IP) | Printing | Scanning | PC-Fax Send ¹ | PC-FAX Receive ¹ | Photo Capture Center™ | Remote Setup ¹ | Status Monitor |
|---|--|---|----------|----------|--------------------------|-----------------------------|-----------------------|---------------------------|----------------|
| Windows® 2000 / Windows® XP/ Windows® XP Professional x64 Edition/ Windows Vista™ | ✓ | ✓ | ✓ | ✓ | ✓ | ✓ | ✓ | ✓ | ✓ |
| Mac OS® X 10.2.4 or greater | ✓ | ✓ | ✓ | ✓ | ✓ | | ✓ | ✓ | ✓ |

¹ Not available for DCP models.

To use the Brother machine through a network, you need to configure the print server, and set up the computers you use.

For Wireless Users:

To achieve optimum results with normal every day document printing, place the Brother machine as close to the network access point (or router) as possible with minimal obstructions. Large objects and walls between the two devices as well as interference from other electronic devices can affect the data transfer speed of your documents.

Due to these factors, wireless may not be the best method of connection for all types of documents and applications. If you are printing large files, such as photos on glossy paper or multi-page documents with mixed text and large graphics, you may want to consider choosing wired Ethernet for a faster data transfer, or USB for the fastest throughput speed.

Network features

Your Brother machine has the following basic network functions.

Network printing

The print server provides printing services for Windows® 2000/XP/XP Professional x64 Edition and Windows Vista™ supporting the TCP/IP protocols and Macintosh® supporting TCP/IP (Mac OS® X 10.2.4 or greater).

Network scanning

You can scan documents over the network to your computer (See *Network Scanning* in the Software User's Guide).

Network PC-FAX (Not available for DCP models)

You can directly send a PC file as a PC-FAX over your network (See *Brother PC-FAX Software* for Windows® and *Sending a Fax* for Macintosh® in the Software User's Guide for a complete description). Windows® users can also PC-FAX receive (See *PC-FAX receiving* in the Software User's Guide).

Network PhotoCapture Center™

You can view, retrieve and save data from a USB flash memory drive or a media card inserted into the Brother machine. The software is automatically installed when you select network connection during the software installation. For Windows®, choose the **PhotoCapture** tab of the **ControlCenter3**. For more information, see *ControlCenter3* in the Software User's Guide. For Macintosh®, launch any web browser in which FTP is available and enter FTP://xxx.xxx.xxx.xxx (where xxx.xxx.xxx.xxx is the IP address of your Brother machine).

Management utilities

BRAdmin Light

BRAdmin Light is a utility for initial setup of the Brother network connected devices. This utility can search for Brother product on your network, view the status and configure basic network settings, such as IP address from a computer running Windows® systems and Mac OS® X 10.2.4 or greater. For installing BRAdmin Light on Windows®, please see the Quick Setup Guide we provided with the machine. For Macintosh® users, BRAdmin Light will be installed automatically when you install the printer driver. If you have already installed the printer driver, you don't have to install it again.

For more information on BRAdmin Light, visit us at <http://solutions.brother.com>.

BRAdmin Professional (for Windows®)

BRAdmin Professional is a utility for more advanced management of network connected Brother devices. This utility can search for Brother products on your network, view the status and configure the network settings from a computer running Windows® system. BRAdmin Professional has additional features from BRAdmin Light.

For more information and downloading, visit us at <http://solutions.brother.com>.

Web BRAdmin (for Windows®)

Web BRAdmin is a utility for managing network connected Brother devices on your LAN and WAN. This utility can search for Brother product on your network, view its status and configure the network settings. Unlike BRAdmin Professional, which is designed for Windows® only, the Web BRAdmin server utility can be accessed from any client PC with a web browser that supports JRE (Java Runtime Environment). By installing the Web BRAdmin server utility on a PC running IIS ¹, administrators with a web browser can connect to the Web BRAdmin server, which then communicates with the device itself.

For more information and downloading, visit us at <http://solutions.brother.com>.

¹ Internet Information Server 4.0 or Internet Information Service 5.0/5.1/6.0/7.0

Remote Setup (Not available for DCP models)

The Remote Setup software allows you to configure network settings from a Windows® or Macintosh® (Mac OS® X 10.2.4 or greater). (See *Remote Setup* in the Software User's Guide).



Note

We recommend Microsoft Internet Explorer 6.0® (or higher) or Firefox® 1.0 (or higher) for Windows® and Safari™ 1.0 for Macintosh®. Please also make sure that JavaScript and Cookies are always enabled in whichever browser you use. We recommend you upgrade to Safari™ 1.2 or higher to enable JavaScript. If a different web browser is used, make sure it is compatible with HTTP 1.0 and HTTP 1.1.

Types of Network Connections

Network Connection Example

Peer-to-Peer printing using TCP/IP

In a Peer-to-Peer environment, each computer directly sends and receives data to each device. There is no central server controlling file access or printer sharing.

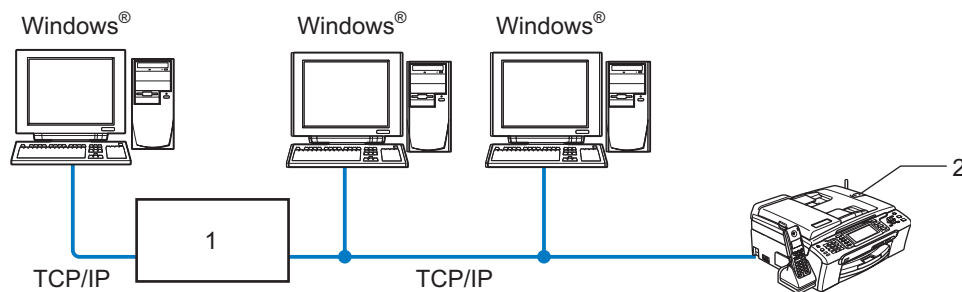

1 Switch or Router

2 Network printer (your machine)

- In a smaller network of 2 or 3 computers, we recommend the Peer-to-Peer printing method as it is easier to configure than the Network Shared Printing method described on the following page. See *Network Shared Printing* on page 5.
- Each computer must use the TCP/IP Protocol.
- The Brother machine needs an appropriate IP address configuration.
- If you are using a router, the Gateway address must be configured on the computers and the Brother machine.

Network Shared Printing

In a Network Shared environment, each computer sends data via a centrally controlled computer. This type of computer is often called a “Server” or a “Print Server”. Its job is to control the printing of all print jobs.

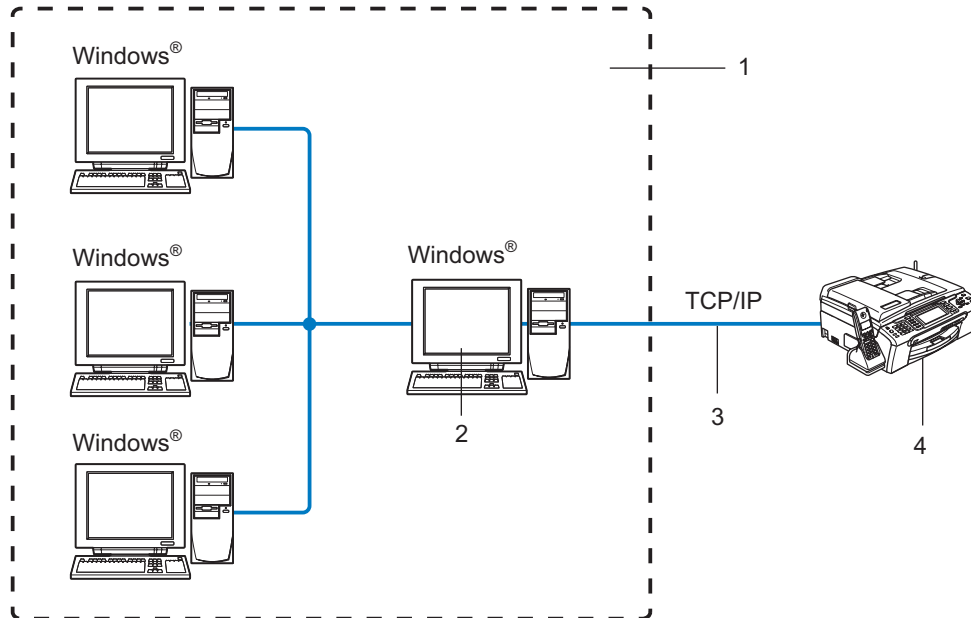

- 1 Network Shared
- 2 Also known as “Server” or “Print Server”
- 3 TCP/IP or USB
- 4 Network printer (your machine)

- In a larger network, we recommend a Network Shared printing environment.
- The “Server” or the “Print Server” must use the TCP/IP Print Protocol.
- The Brother machine needs an appropriate IP address configuration unless the machine is shared via the USB port of the server.

Wireless network connection example

1

Connected to a wireless capable computer with an access point on the network (Infrastructure mode)

This type of network has a central access point at the heart of the network. The access point can also act as a bridge or a gateway to a wired network. When the Brother wireless machine (your machine) is part of this network, it receives all print jobs via an access point.

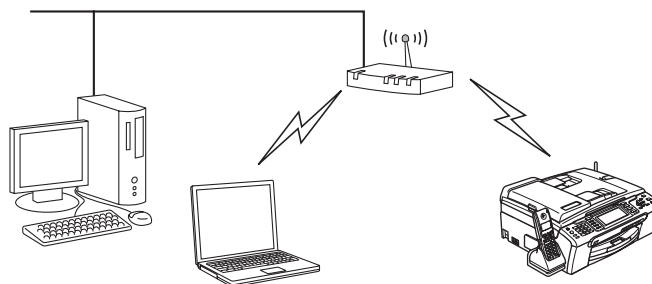

Connected to a wireless capable computer without an access point on the network (Ad-hoc mode)

This type of network does not have a central access point. Each wireless client communicates directly with each other. When the Brother wireless machine (your machine) is part of this network, it receives all print jobs directly from the computer sending the print data.

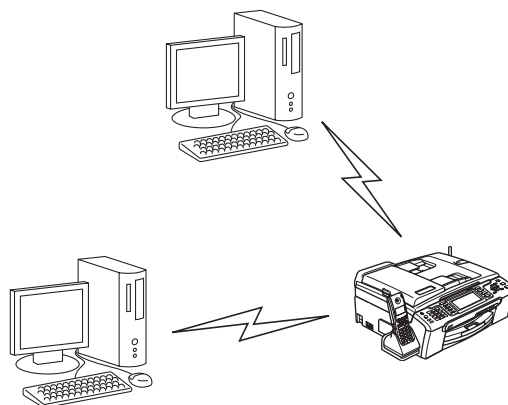

An access point is on the network, but the computer is not wireless capable

This type of network has a central access point at the heart of the network. The access point is connected to a computer which is not wireless capable with an Ethernet cable. When the Brother wireless machine (your machine) is a part of this network, it receives all print jobs via an access point.

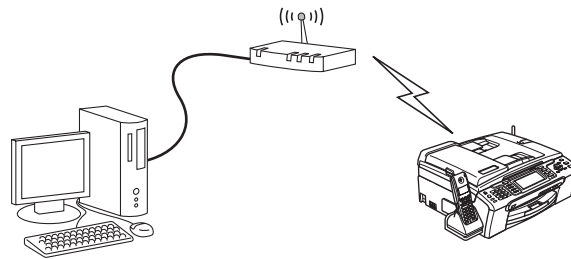

Protocols

TCP/IP protocols and functions

Protocols are the standardized sets of rules for transmitting data on a network. Protocols allow users to gain access to network connected resources. The print server used on this Brother product supports the TCP/IP (Transmission Control Protocol/Internet Protocol) protocols. TCP/IP is the most popular set of protocols used for communication such as Internet and E-mail. This protocol can be used in almost all operating systems such as Windows®, Macintosh® and Linux. The following TCP/IP protocols are available on this Brother product.

DHCP/BOOTP/RARP

By using the DHCP/BOOTP/RARP protocols, the IP address can be automatically configured.

**Note**

To use the DHCP/BOOTP/RARP protocols, please contact your network administrator.

APIPA

If you do not assign an IP address manually (using the control panel of the machine or the BRAdmin software) or automatically (using a DHCP/BOOTP/RARP server), the Automatic Private IP Addressing (APIPA) protocol will automatically assign an IP address from the range 169.254.1.0 to 169.254.254.255.

DNS client

The Brother print server supports the Domain Name System (DNS) client function. This function allows the print server to communicate with other devices by using its DNS name.

LPR/LPD

Commonly used printing protocols on a TCP/IP network.

Port9100

Another commonly used printing protocol on a TCP/IP network.

mDNS

mDNS allows the Brother print server to automatically configure itself to work in a Mac OS® X Simple Network Configured system. (Mac OS® X 10.2.4 or greater).

TELNET

The Brother print server supports TELNET server for command line configuration.

SNMP

The Simple Network Management Protocol (SNMP) is used to manage network devices including computers, routers and Brother network ready machines.

LLTD

The Link Layer Topology Discovery protocol (LLTD) lets you locate the Brother machine easily on the Windows Vista™ **Network Map**. Your Brother machine will be shown with a distinctive icon and the node name. The default setting for this protocol is Off.

You can activate LLTD using the BRAdmin Professional utility software. Visit the download page for your model at <http://solutions.brother.com> to download BRAdmin Professional.

Web Services

The Web Services protocol enables Windows Vista™ users to install the Brother printer driver by right-clicking the machine icon from the **Start / Network** selection. (See *Installation when using Web Services (For Windows Vista™ users)* on page 117). The Web Services also lets you check the current status of the machine from your computer.

Overview

Before you can use your Brother machine on your network, you need to install the Brother software and also configure the appropriate TCP/IP network settings on the machine itself. To do this, we recommend that you use the automatic installer on the Brother CD-ROM as this will guide you through the software and network installation.

If you do not wish to use the automatic installer, or you do not understand some of the terms used by the automatic installer, refer to the remainder of this chapter for more information.



Note

If you do not wish to, or are unable to use the automatic installer or any of Brother's software tools, you can also use the machine's control panel to change network settings. For more information, see *Control panel setup* on page 82.

IP addresses, subnet masks and gateways

To use the machine in a networked TCP/IP environment, you need to configure its IP address and subnet mask. The IP address you assign to the print server must be on the same logical network as your host computers. If it is not, you must properly configure the subnet mask and the gateway address.

IP address

An IP address is a series of numbers that identifies each device connected to a network. An IP address consists of four numbers separated by dots. Each number is between 0 and 255.

- Example: In a small network, you would normally change the final number.

192.168.1.1, 192.168.1.2, 192.168.1.3

If you have a DHCP/BOOTP/RARP server in your network (typically a UNIX®/Linux, Windows® 2000/XP or Windows Vista™ network) the print server will automatically obtain its IP address from that server.



Note

On smaller networks, the DHCP server may be the Router.

For more information on DHCP, BOOTP and RARP, see *Using DHCP to configure the IP address* on page 112, *Using BOOTP to configure the IP address* on page 112 and *Using RARP to configure the IP address* on page 113.

If you do not have a DHCP/BOOTP/RARP server, the Automatic Private IP Addressing (APIPA) protocol will automatically assign an IP address from the range 169.254.1.0 to 169.254.254.255. For more information on APIPA, see *Using APIPA to configure the IP address* on page 114.

If the APIPA protocol is disabled, the default IP address of a Brother print server is 192.0.0.192. However, you can easily change this IP address number to match with the IP address details of your network. For information on how to change the IP address, see *Setting up the IP address and subnet mask* on page 12.

Subnet mask

Subnet masks restrict network communication.

■ Example: Computer1 can talk to Computer2

- Computer1

IP Address: 192.168.1.2

Subnet Mask: 255.255.255.0

- Computer2

IP Address: 192.168.1.3

Subnet Mask: 255.255.255.0



Note

0 denotes that there is no limit to communication at this part of the address.

In the above example, we can communicate with anything that has an IP address that begins with 192.168.1.X.

Gateway (and router)

A gateway is a network point that acts as an entrance to another network and sends data transmitted via the network to an exact destination. The router knows where to direct data that arrives at the gateway. If a destination is located at an external network, the router transmits data to the external network. If your network communicates with other networks, you may need to configure the Gateway IP address. If you do not know the Gateway IP address then contact your Network Administrator.

Setting up the IP address and subnet mask

Using the BRAdmin Light utility to configure your machine for the network printer

2

BRAdmin Light

The BRAdmin Light utility is designed for initial setup of the Brother network connected devices. It also can search for Brother products in a TCP/IP environment, view the status and configure basic network settings, such as IP address. The BRAdmin Light utility is available for Windows® 2000/XP, Windows Vista™ and Mac OS® X 10.2.4 or greater.

How to configure your machine using the BRAdmin Light utility



Note

- Please use the BRAdmin Light utility version that was supplied on the CD-ROM of your Brother product. You can also download the latest Brother BRAdmin Light utility version from <http://solutions.brother.com>.
- If you require more advanced printer management, use the latest Brother BRAdmin Professional utility that is available as a download from <http://solutions.brother.com>. This utility is only available for Windows® users.
- If you are using personal Firewall software, disable it. Once you are sure that you can print, re-start your personal Firewall software.
- Node Name: Node Name appears in current BRAdmin Light. The default Node Name of the network card in the machine is "BRNxxxxxxxxxxx" ("xxxxxxxxxxx" is your machine's Ethernet address.).
- By default, no password is required. To set a password, double click the device you want to set a password. Click **Control** tab, and then click **Change Password**. Enter the new password.

1 Start the BRAdmin Light utility.

- For Windows® 2000/XP and Windows Vista™

Click **Start / All Programs**¹ / **Brother / BRAdmin Light / BRAdmin Light**.

¹ **Programs** for Windows® 2000 users

- For Mac OS® X 10.2.4 or greater users

Double-click **Macintosh HD (Startup Disk) / Library / Printers / Brother / Utilities / BRAdmin Light.jar** file.

2 BRAdmin Light will search for new devices automatically.

- 3 Double-click the unconfigured device.
Windows®

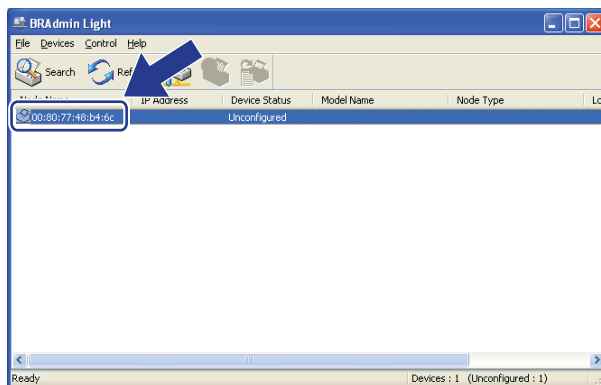

Macintosh®

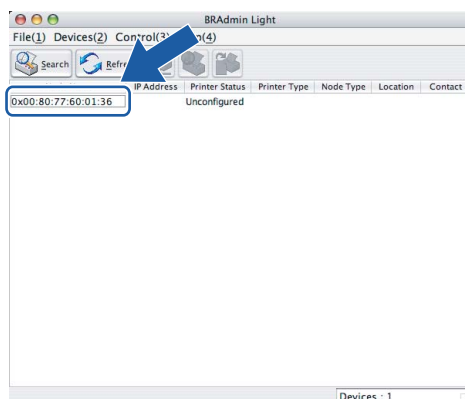

 **Note**

- If the print server is set to its factory default settings without using a DHCP/BOOTP/RARP server, the device will appear as **Unconfigured** in the BRAdmin Light utility screen.
- You can find the Node Name and Ethernet address by printing the Network Configuration List. See *Printing the Network Configuration List* on page 93 for information on how to print the Network Configuration List on your print server.

- 4 Choose **Static** from **Boot Method**. Enter the **IP address**, **Subnet Mask** and **Gateway** (if needed) of your print server.

Windows®

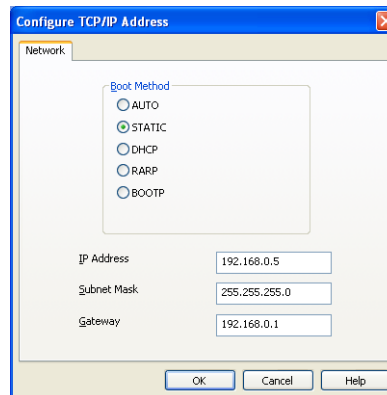

Macintosh®

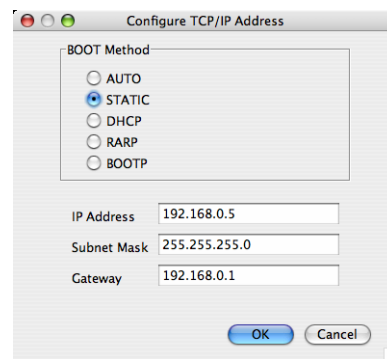

- 5 Click **OK**.
- 6 With the correctly programmed IP address, you will see the Brother print server in the device list.

Using the control panel to configure your machine for a network

You can configure your machine for a network using the control panel LAN menu. See *Control panel setup* on page 82.

Using other methods to configure your machine for a network

You can configure your machine for a network using other methods. See *Other ways to set the IP address (for advanced users and administrators)* on page 112.

Changing the print server settings

Using the BRAdmin Light utility to change the print server settings

2

- 1 Start the BRAdmin Light utility.
 - For Windows® 2000/XP and Windows Vista™ users
Click **Start / All Programs** ¹ / **Brother / BRAdmin Light / BRAdmin Light**.
¹ **Programs** for Windows® 2000 users
 - For Mac OS® X 10.2.4 or greater users
Double-click **Macintosh HD (Startup Disk) / Library / Printers / Brother / Utilities / BRAdmin Light.jar** file.
- 2 Select the print server which you want to change the settings.
- 3 Select **Network Configuration** from the **Control** menu.
- 4 Enter a password if you have set it.
- 5 You can now change the print server settings.



Note

If you want to change more advanced settings, use the BRAdmin Professional utility that is available as a download from <http://solutions.brother.com>.

Using the control panel to change the print server settings

You can configure and change the print server settings using the control panel LAN menu. See *Control panel setup* on page 82.

Using the Remote Setup to change the print server settings (Not available for DCP models)

Remote Setup for Windows®

The Remote Setup application allows you to configure network settings from a Windows® application. When you access this application, the settings on your machine will be downloaded automatically to your PC and displayed on your PC screen. If you change the settings, you can upload them directly to the machine.

- 1 Click the **Start** button, **All Programs**, **Brother**, **MFC-XXXX LAN**, then **Remote Setup** (where XXXX is your model name).
- 2 Enter a password if you have set it.
- 3 Click **TCP/IP (Wired)** or **Setup Misc.**
- 4 You can now change the print server settings.

Remote Setup for Macintosh®

The Remote Setup application allows you to configure many MFC settings from a Macintosh® application. When you access this application, the settings on your machine will be downloaded automatically to your Macintosh® and displayed on your Macintosh® screen. If you change the settings, you can upload them directly to the machine.

- 1 Double click the **Macintosh HD** icon on your desktop, **Library**, **Printers**, **Brother**, then **Utilities**.
- 2 Double click the **Remote Setup** icon.
- 3 Enter a password if you have set it.
- 4 Click **TCP/IP (Wired)** or **Setup Misc.**
- 5 You can now change the print server settings.

Overview

To connect your machine to your wireless network, you need to follow the steps in the Quick Setup Guide. We recommend that you use the Setup Wizard from the machine's control panel LAN menu. By using this method, you can easily connect your machine to your wireless network. Please follow the instructions in the supplied Quick Setup Guide.

Please read this chapter for more details on how to configure the wireless network settings. For information on TCP/IP settings, see *Setting up the IP address and subnet mask* on page 12. Then, in *Network printing from Windows® basic TCP/IP Peer-to-Peer printing* on page 100 and *Network printing from a Macintosh®* on page 102, you will learn how to install the network software and drivers into the operating system running on your computer.

Confirm your network environment

Wireless network connection example

Connected to a wireless capable computer with an access point on the network (Infrastructure mode)

This type of network has a central access point at the heart of the network. The access point can also act as a bridge or a gateway to a wired network. When the Brother wireless machine (your machine) is part of this network, it receives all print jobs via an access point.

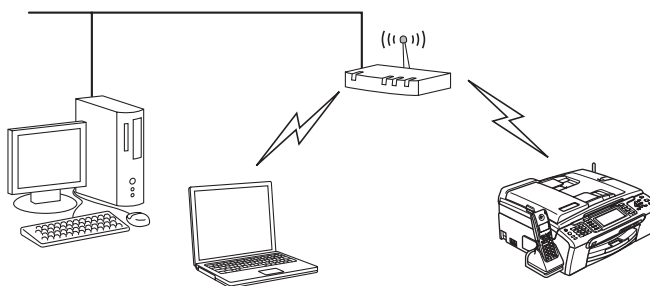

Connected to a wireless capable computer without an access point on the network (Ad-hoc mode)

This type of network does not have a central access point. Each wireless client communicates directly with each other. When the Brother wireless machine (your machine) is part of this network, it receives all print jobs directly from the computer sending the print data.

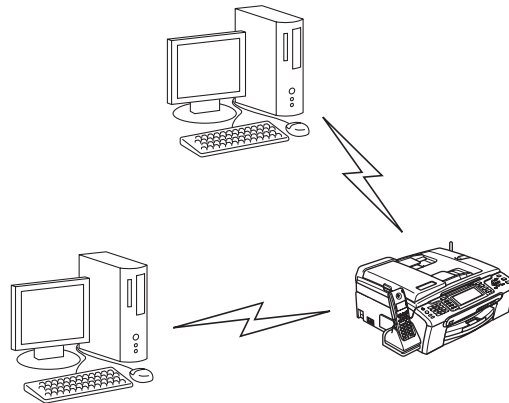

An access point is on the network, but the computer is not wireless capable

This type of network has a central access point at the heart of the network. The access point is connected to a computer which is not wireless capable with the Ethernet cable. When the Brother wireless machine (your machine) is a part of this network, it receives all print jobs via an access point.

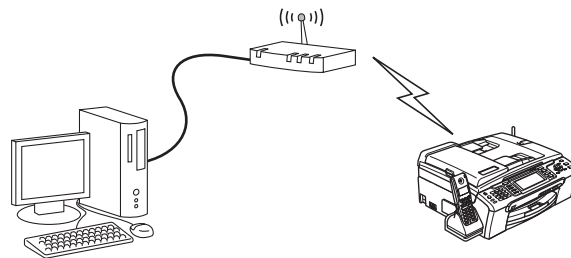

Confirm your network environment

The setup process will be different depending on your network environment

Configuration using SecureEasySetup™ or AOSS™.

If your wireless access point(A) supports SecureEasySetup™ or AOSS™, you do not need to use a computer to configure the printer. The access point (router) and your machine can automatically negotiate using the SecureEasySetup™ or AOSS™ procedure.

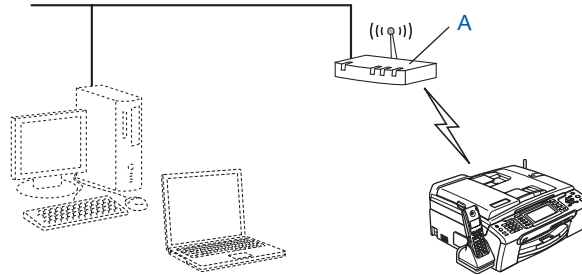

Configuration temporarily using a network cable

If there is an Ethernet Hub or Router in the same network as the wireless access point of your machine, you can temporarily connect the Hub or Router to the machine using an Ethernet cable(B), this is an easy way to configure the machine. You can then remotely configure the machine from a computer on the network.

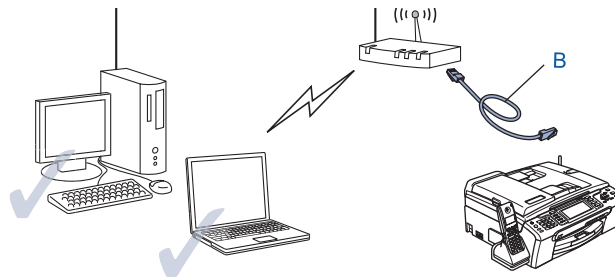

Configuration using a wireless computer.

If your computer has wireless capability, you will need to change the wireless settings of the computer to Ad-hoc mode so you can directly connect and configure the machine.

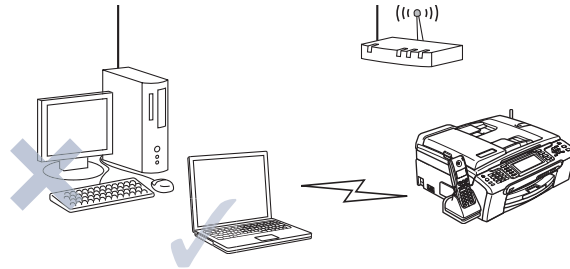

Wireless network terms and concepts

When you configure the wireless network machine, you must ensure that your wireless network machine is configured to match the settings of the existing wireless network. This section provides some of main terms and concepts of these settings, which may be helpful when you configure the wireless network machine.

SSID (Service Set Identifier) and channels

You need to configure the SSID and a channel to specify the wireless network you want to connect to.

SSID

Each wireless network has its own unique network name and it is technically referred to as SSID or ESSID (Extended Service Set Identifier). The SSID is a 32-byte or less value and is assigned to the access point. The wireless network devices you want to associate to the wireless network should match the access point. The access point and wireless network devices regularly send wireless packets (referred to as a beacon) which has the SSID information. When your wireless network device receives a beacon, you can identify the wireless network that is close enough for the radio waves to reach your device.

Channels

Wireless networks use channels. Each wireless channel is on a different frequency. When configuring your Brother device to work in a wireless network, you must set it to the channel that is used on the wireless network that you are connecting to. There are up to 14 different channels that can be used when using a wireless network. However, in many countries the number of channels available are restricted. For further information, see *Ethernet wireless network* on page 120.

Authentication and encryption

Most wireless networks use some kind of security settings. These security settings define the authentication (how the device identifies itself to the network) and encryption (how the data is encrypted as it is sent on the network). If you do not correctly specify these options when you are configuring your Brother wireless device, it will not be able to connect to the wireless network. Therefore care must be taken when configuring these

options. Please refer to the information below to see which authentication and encryption methods your Brother wireless device supports.

Authentication methods

The Brother machine supports the following methods:

- Open system

Wireless devices are allowed access the network without any authentication.

- Shared key

A secret pre-determined key is shared by all devices that will access the wireless network.

The Brother machine uses the WEP keys as the pre-determined key.

- WPA-PSK/WPA2-PSK

Enables a Wi-Fi® Protected Access Pre-shared key (WPA-PSK/WPA2-PSK), which enables the Brother wireless machine to associate with access points using TKIP for WPA-PSK or AES for WPA-PSK and WPA2-PSK encryption (WPA-Personal).

Encryption methods

Encryption is used to secure the data that is sent over the wireless network. The Brother machine supports the following encryption methods:

- None

No encryption method is used.

- WEP

By using WEP (Wired Equivalent Privacy), the data is transmitted and received with a secure key.

- TKIP

TKIP (Temporal Key Integrity Protocol) provides per-packet key mixing a message integrity check and re-keying mechanism.

- AES

AES (Advanced Encryption Standard) is Wi-Fi® authorized strong encryption standard.

Network key

There are some rules for each security method:

- Open system/Shared key with WEP

This key is a 64-bit or 128-bit value that must be entered in an ASCII or HEXADECIMAL format.

| | |
|----------------------------|---|
| 64 (40) bit ASCII: | Uses 5 text characters.e.g. "WLLAN" (this is case sensitive). |
| 64 (40) bit hexadecimal: | Uses 10 digits of hexadecimal data.e.g. "71f2234aba" |
| 128 (104) bit ASCII: | Uses 13 text characters.e.g. "Wirelesscomms" (this is case sensitive) |
| 128 (104) bit hexadecimal: | Uses 26 digits of hexadecimal datae.g. "71f2234ab56cd709e5412aa2ba" |

- WPA-PSK/WPA2-PSK and TKIP or AES

Uses a Pre-Shared Key (PSK) that is 8 or more characters in length, up to a maximum of 63 characters.

Configuring your machine for a wireless network

There are three methods to configure your wireless network machine; by using the machine control panel (recommended), using the SecureEasySetup™ or AOSS™ software and using the automatic installer application on the CD-ROM.

Using the Setup Wizard from the control panel

You can configure your print server by using the `Setup Wizard` function. This is located in the `LAN` menu on the machine's control panel. See to the steps below for further information.

- 1 Press **Menu**.
- 2 Press **▲** or **▼** to select `LAN`.
Press **OK**.
- 3 Press **▲** or **▼** to select `Network I/F`.
Press **OK**.
- 4 Press **▲** or **▼** to select `WLAN`.
Press **OK**. The wireless network interface will be activated.
- 5 Press **▲** or **▼** to select `WLAN`.
Press **OK**.
- 6 Press **▲** or **▼** to select `Setup Wizard`.
Press **OK**.
- 7 Start to search for a SSID around the machine.
- 8 After a few seconds, you can select the SSID from the list using **▲** or **▼**. Press **OK** to select the SSID.
If you select the SSID displayed, go to 12.

If you want to add a new SSID name, go to 9.

- 9 Select <New SSID> using ▲ or ▼.
Press **OK**. Go to 10.
- 10 Enter the SSID name. (For information how to type text, see *Entering Text* on page 125.)
Press **OK**. Go to 11.
- 11 Using ▲ or ▼, select `Infrastructure` when instructed.
Press **OK**. Go to 12
If you select `Ad-hoc`, go to 13.
- 12 Select the Authentication method using ▲ or ▼, and press **OK**.
If you select `Open System`, go to 13.
If you select `Shared Key`, go to 14.
If you select `WPA/WPA2-PSK`, go to 17.
- 13 Select the Encryption type, `None` or `WEP` using ▲ or ▼, and press **OK**.
If you select `None`, go to 19.
If you select `WEP`, go to 14.
- 14 Select the key option; `KEY1`, `KEY2`, `KEY3`, `KEY4` using ▲ or ▼, and press **OK**.
If you select the key which shows `*****`, go to 15.
If you select a blank key, go to 16.
- 15 If you want to change the key you selected in 14, press ▲ or ▼ to select `Change`. Press **OK**. Go to 16.
If you want to keep the key you selected in 14, press ▲ or ▼ to select `Keep`. Press **OK**. Go to 19.
- 16 Enter a new WEP key. Press **OK**. Go to 19. (To manually enter the text, see *Entering Text* on page 125)
- 17 Select the Encryption type, `TKIP` or `AES` using ▲ or ▼. Press **OK**. Go to 18.
- 18 Enter the password and press **OK**. Go to 19. (To manually enter the text, see *Entering Text* on page 125)
- 19 The following will be displayed.
To apply the settings, select `Yes`. To cancel, select `No`.
If you select `Yes`, go to 20.
If you select `No`, go back to 8.
- 20 The machine starts to connect to the wireless device you have selected.
- 21 If your wireless device is connected successfully, the display shows `Connected` for 60 seconds and configuration is completed.
If the connection failed, the display shows `Connection Error` for 60 seconds. See *Wireless network troubleshooting* on page 111.
- 22 Press **OK**.

Using the SecureEasySetup™ or AOSS™ software to configure your machine for a wireless network

The SecureEasySetup™ or AOSS™ software allows you to configure the wireless network easier than configuring it manually. By pushing a button on the wireless router or access point, you can complete setup and secure the wireless network. Your router or access point must also support SecureEasySetup™ or AOSS™. See the user's guide for your wireless LAN router or access point for instructions on how to use the SecureEasySetup™ or AOSS™ mode.



Note

Routers or access points that support SecureEasySetup™ or AOSS™ have the SecureEasySetup™ or AOSS™ symbol as shown below.



- 1 Push the SecureEasySetup™ or AOSS™ button on your wireless router or access point. See the user's guide for your wireless router or access point for instructions.
- 2 Press **Menu** on the control panel of the Brother machine.
- 3 Press **▲** or **▼** to select LAN.
Press **OK**.
- 4 Press **▲** or **▼** to select WLAN.
Press **OK**.
- 5 Press **▲** or **▼** to select SecurEasySetup or AOSS.
Press **OK**.
- 6 The wireless network connection status using the SecureEasySetup™ or AOSS™ software will be displayed; Connecting WLAN, Setting AOSS or Connecting AOSS.
Wait till either Connected or Connection Error (Connection Fail) is displayed.
Connected is displayed when the print server is successfully connected to your router or access point. You can now use your machine in a wireless network.
Connection Error (Connection Fail) is displayed when the print server has not successfully connected to your router or access point. Try starting from 1 again. If the same message is displayed again, reset the print server back to the default factory settings and try again.

7 Press OK.

Using the Brother automatic installer application on the CD-ROM to configure your machine for a wireless network

See *Wireless Configuration for Windows®* on page 29 and *Wireless Configuration for Macintosh®* on page 57 for information on how to use the Brother automatic installer application on the CD-ROM we have provided with the machine.

Changing the print server settings

Once you have configured your machine for a wireless network, you can change the wireless settings using the BRAdmin Professional utility, the Remote Setup software or the control panel on the front of the Brother machine.

Using the BRAdmin Professional utility to change the wireless settings (for Windows®)



Note

- Please use the latest version of the BRAdmin Professional utility that is available as a download from <http://solutions.brother.com>. This utility is only available for Windows® users.
- If you are using Personal Firewall software, disable it. Once you are sure that you can print, re-start your Personal Firewall software.
- Node name: Node name appears in current BRAdmin Professional window. The default Node name is “BRNxxxxxxxxxxxxx” or “BRWxxxxxxxxxxxxx” (“xxxxxxxxxxxxx” is your Ethernet address.).

- 1 Start the BRAdmin Professional utility (from Windows® 2000/XP or Windows Vista™), by clicking **Start / All Programs / Brother Administrator Utilities / Brother BRAdmin Professional Utilities / BRAdmin Professional**.

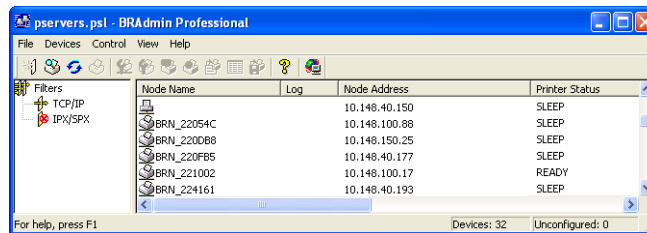

- 2 Select **TCP/IP** in the left frame of the main BRAdmin window.
- 3 Select the print server which you want to configure, in the right frame of the main BRAdmin window.
- 4 Select **Configure Wireless Setting** from the **Control** menu.
- 5 Enter a password if you have set it.



Note

By default, no password is required to change the print server settings. You can set a password to change the print server settings. Double click the device you want to set a password. Click **Control** tab, and then click **Change Password**. Enter the new password.

6 You can now change the wireless settings.



Note

- If the print server is set to its factory default settings without using a DHCP/BOOTP/RARP server, the device will appear as APIPA in the BRAdmin Professional utility screen.
- You can find the node name and Ethernet address (**Node Address** above) by printing out the Network Configuration List. See *Printing the Network Configuration List* on page 93 for information on how to print the Network Configuration List on your print server.

3

Using the control panel to change the print server settings

You can configure and change the print server settings using the control panel LAN menu. See *Control panel setup* on page 82.

Using other methods to configure your machine for a wireless network

You can configure your machine for a wireless network using other methods. See *Other ways to set the IP address (for advanced users and administrators)* on page 112.

Using the Remote Setup to change the print server settings (Not available for DCP models)

Remote Setup for Windows®

The Remote Setup application allows you to configure network settings from a Windows® computer. When you access this application, the settings on your machine will be downloaded automatically to your PC and displayed on your PC screen. If you change the settings, you can upload them directly to the machine.

- 1 Click the **Start** button, **All Programs**, **Brother**, **MFC-XXXX LAN**, then **Remote Setup** (where XXXX is your model name).
- 2 Enter a password if you have set it.
- 3 Click **TCP/IP (WLAN)**.
- 4 You can now change the print server settings.

Remote Setup for Macintosh®

The Remote Setup application allows you to configure many MFC settings from a Macintosh®. When you access this application, the settings on your machine will be downloaded automatically to your Macintosh® and displayed on your Macintosh® screen. If you change the settings, you can upload them directly to the machine.

- 1 Double click the **Macintosh HD** icon on your desktop, **Library**, **Printers**, **Brother**, then **Utilities**.
- 2 Double click the **Remote Setup** icon.
- 3 Enter a password if you have set it.
- 4 Click **TCP/IP (WLAN)**.
- 5 You can now change the print server settings.

Configuration in Infrastructure mode

For Windows® 2000 Professional/XP or Windows Vista™

IMPORTANT

If you have previously configured the wireless settings of the machine, you must reset the network LAN settings before you can configure the wireless settings again. Press **Menu**, **▲** or **▼** for **LAN**, **Factory Reset** and select **Yes** to accept the change. The machine will restart automatically.

- 1 Turn on the machine by plugging in the power cord.

(For US)

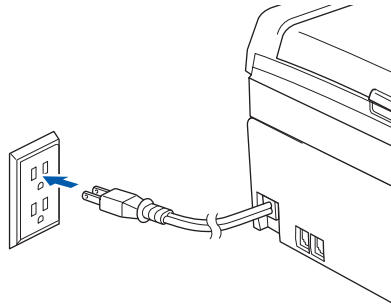

(For UK)

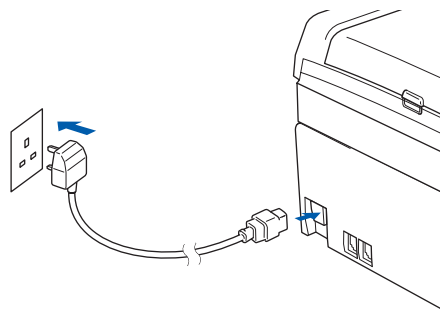

- 2 Turn on your computer.



Note

Before configuration, if you are using personal firewall software, disable it. Once you are sure that you can print after the installation, restart your personal firewall software.

- 3 Put the supplied CD-ROM into your CD-ROM drive. If the model name screen appears, choose your machine. If the language screen appears, choose your language.

- 4 The CD-ROM main menu will appear. Click **Install Other Drivers or Utilities**.
(For US)



(For UK)



Note

If this window does not appear, use Windows® Explorer to run the `sart.exe` program from the root folder of the Brother CD-ROM.

- 5 Click **Wireless LAN Setup Wizard**.



- 6 Choose **Manual** and then click **Next**.

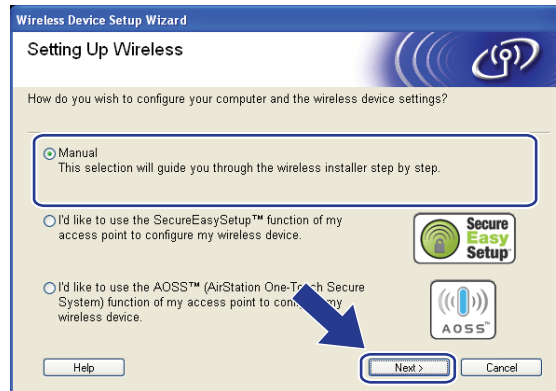

7 For configuration, it is recommended that you temporarily connect your Brother wireless device directly to a free port on your access point, hub or router using a network cable.

- If you can temporarily connect with a network cable:

Choose **I'm able to temporarily connect my device to my access point with a network cable** and then click **Next**.

Go to 8.

- If you do not have a network cable or cannot temporarily connect the Brother wireless device to your access point:

Choose **I'm not able to connect my device to my access point with a network cable** and then click **Next**.

Go to 10.

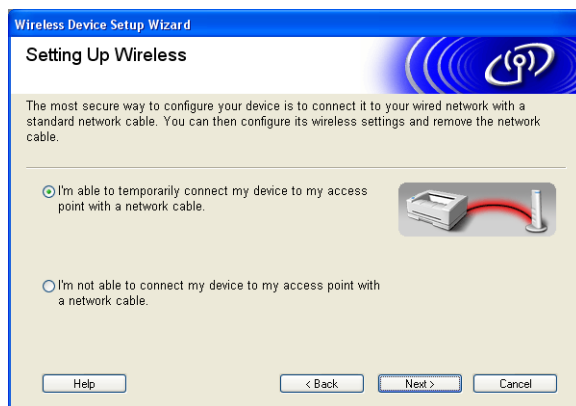

8 Read the **Important Notice** and click **Next**.

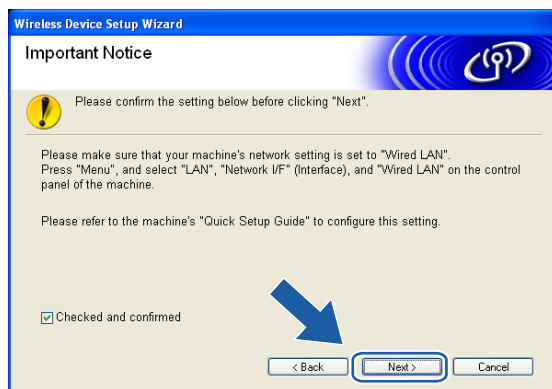

- 9 Connect the Brother wireless device to your access point using a network cable and click **Next**. Go to 14

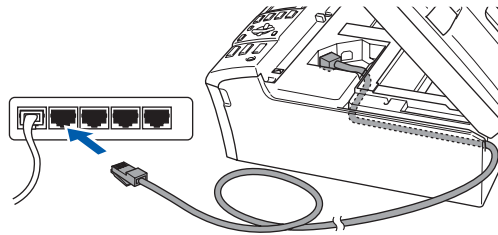
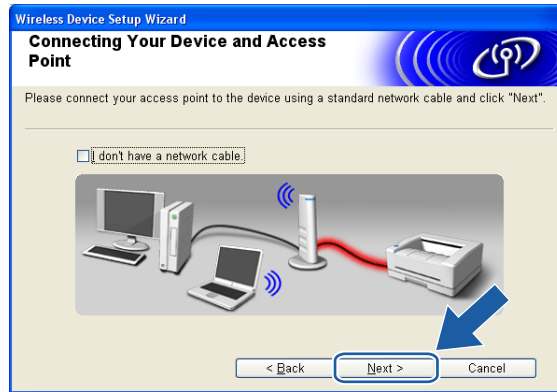

- 10 If you choose **This PC has wireless capability**, check **I am using an access point in infrastructure mode**, and then click **Next**. Go to 11

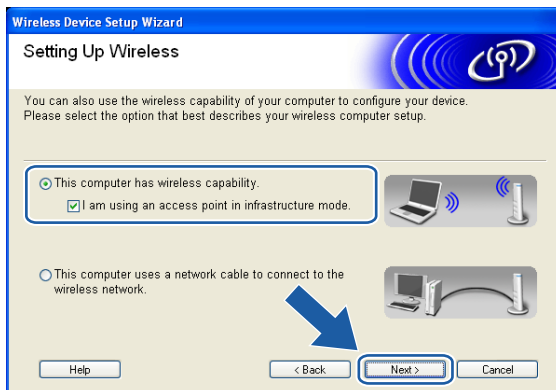

If you are using a wired computer, choose **This PC uses a network cable to connect to the wireless network**, you must configure the wireless settings from the control panel. Click **Next** and follow the on-screen instructions to complete the setup. See *Using the Setup Wizard from the control panel* on page 22.

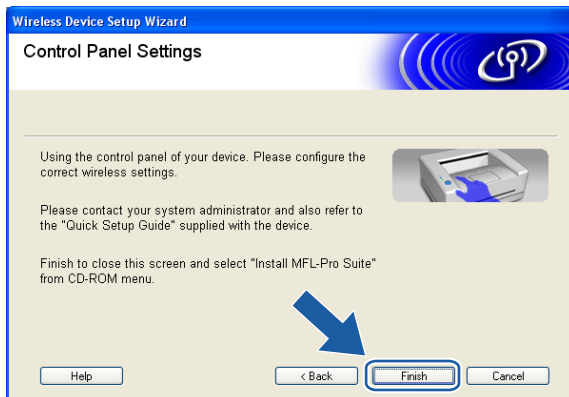

- 11 Read the **Important Notice** and click **Next**.

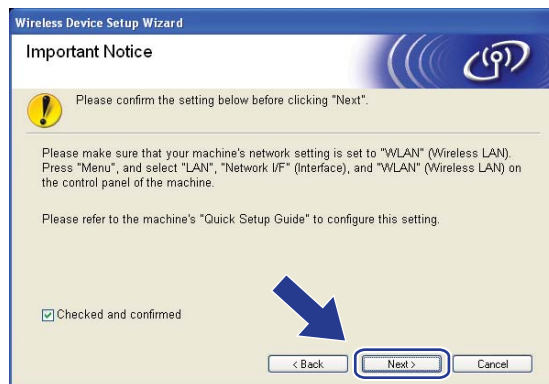

- 12 You need to temporarily change your PC's wireless settings. Please follow the on-screen instructions. Please make sure you take notes on all the settings such as SSID or channel of your PC. You will need them to return your PC back to its original wireless settings.

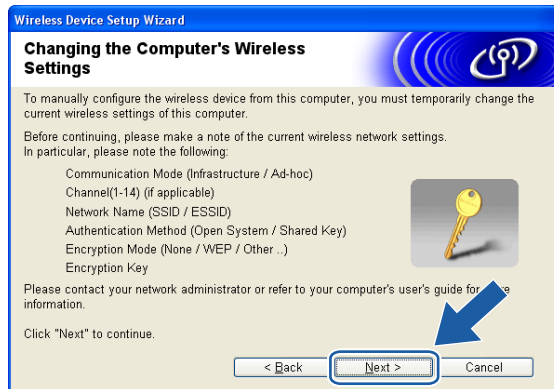

| Item | Record the current wireless computer settings |
|---|---|
| Communication mode:(Infrastructure/Ad-hoc) | |
| Channel: | |
| Network name(SSID/ESSID) | |
| Authentication method(Open system/Shared key) | |
| Encryption:(None/WEP/WPA/WPA2-PSK) | |
| Encryption key: | |

- 13 To communicate with the un-configured wireless machine, temporarily change the wireless settings on your PC to match machine's default settings shown on this screen. Click **Next**.



Note

- If a message to restart your PC appears after the wireless settings have been changed, restart your PC and then go back to step 4 and continue with the install skipping steps 11, 12 and 13.
- For Windows® XP SP2 users you can temporarily change the wireless settings on your PC, following the steps below:
 - 1 Click **Start** and then **Control Panel**.
 - 2 Click **Network Connections** icon.
 - 3 Select and right click **Wireless Network Connection**. Click **View Available Wireless Networks**.
 - 4 You can see the Brother wireless machine in the list. Select **SETUP** and click **Connect**.
 - 5 Check the **Wireless Network Connection** status. It may take a few minutes to change from 0.0.0.0 to 169.254.x.x IP address to be shown on screen (where x.x. are numbers between 1 and 254).
- For Windows Vista™ users:

You can temporarily change the wireless settings on your computer, following the steps below:

 - 1 Click **Start** and then **Control Panel**.
 - 2 Click **Network and Internet** and then **Network and Sharing Center** icon.
 - 3 Click **Connect to a network**.
 - 4 You can see the SSID of the wireless printer in the list. Select **SETUP** and click **Connect**.
 - 5 Click **Connect Anyway** and then **Close**.
 - 6 Click **View status** of **Wireless Network Connection (SETUP)**.
 - 7 Click **Details...** and check the **Network Connection Details**. It may take a few minutes to change from 0.0.0.0 to 169.254.x.x IP address to be shown on screen (where x.x. are numbers between 1 and 254).

- 14 The following list appears. If the list is blank, check if the access point and the machine are powered on, and then click **Refresh**. Choose the machine you wish to configure, and click **Next**.



Note

The Default Node name of the NC-xxxx (where "xxxx" is your model name) is "BRNxxxxxxxxxxxx" or "BRWxxxxxxxxxxxx" (where "xxxxxxxxxxxx" is your Ethernet address).

- 15 The wizard will search for wireless networks available from your machine. Choose the access point you wish to associate the machine with, and then click **Next**.

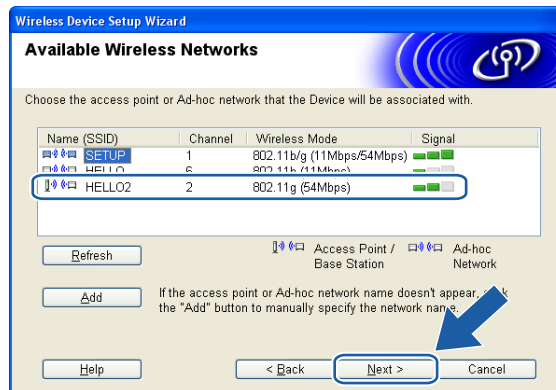

 **Note**

- If your access point is set to not broadcast the SSID you can manually add it by clicking the **Add** button. Follow the on-screen instructions for entering the **Name (SSID)** and the Channel number.
- If the list is blank, check that the access point has power and is broadcasting the SSID, and then see if the machine and the access point are within range for wireless communication. Then, click **Refresh**.
- "SETUP" is the default SSID of the machine. Do not choose this SSID.

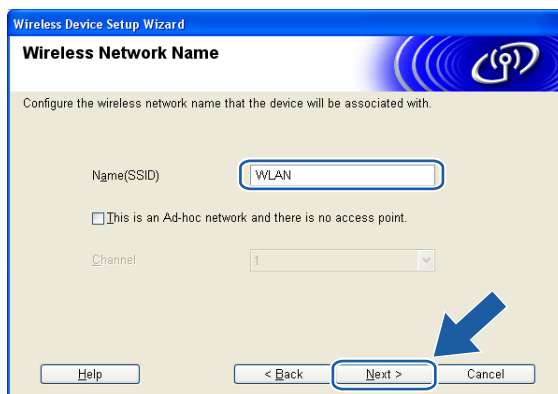

- 16 If your network is not configured for Authentication and Encryption, the following screen will appear. To continue configuration, click **OK** and go to 18.



- 17 If your network is configured for Authentication and Encryption, the following screen will appear. When configuring your Brother wireless machine, you must ensure that it is configured to match the Authentication and Encryption settings of your existing wireless network. Choose the

Authentication Method and **Encryption Mode** from the pull-downs in each setting box. Then enter the **Network key** and click **Next**.

Wireless Device Setup Wizard

Authentication Method and Encryption Mode

Configure the Authentication Method and Encryption mode

Name (SSID) : WLAN

Authentication Method: Open System

Encryption Mode: WEP

Network Key:

Confirm Network Key:

Advanced

Help

< Back Next > Cancel

Note

- If you want to set more than one WEP key, click **Advanced**.
- If you do not know the Authentication or Encryption settings for network, contact your network administrator.

- 18 Click **Next**. The settings will be sent to your machine. The settings will remain unchanged if you click **Cancel**.

Wireless Device Setup Wizard

Wireless Network Settings Confirmation

Click "Next" to submit following settings to the device

Target Device = BRWXXXXXXXXXXXX

IP Address: Auto [Change IP Address](#)

Communication mode: Infrastructure

Name (SSID): WLAN

Authentication Method: Open System

Encryption Mode: WEP

Print test page after submitting settings?

Help

< Back Next > Cancel

Note

- If you want to manually enter the IP address settings of your machine, click **Change IP Address** and enter the necessary IP address settings for your network.
- The control panel settings will be automatically changed to WLAN when the wireless settings are sent to your machine.

- 19 If you choose **I'm able to temporarily connect my device to my access point with a network cable** in step 7; Disconnect the network cable between your access point (hub or router) and the machine, and click **Next**.

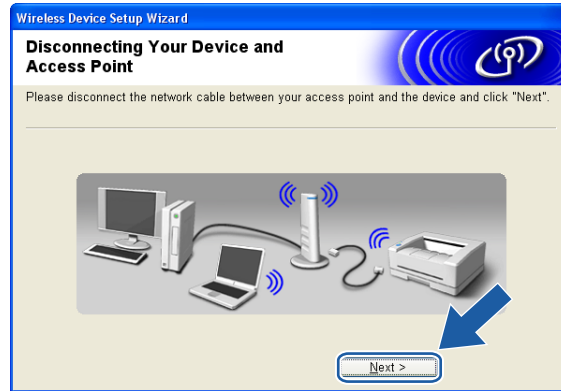

- 20 If you choose **This PC has wireless capability** in step 10; Using the information you recorded in 12, return the wireless settings of your computer back to their original settings. Click **Next**.



- 21 You have completed the wireless setup. Click **Finish**. If you would like to continue installing drivers and software necessary for operating your device, please select **Install MFL-Pro Suite** from CD-ROM menu.

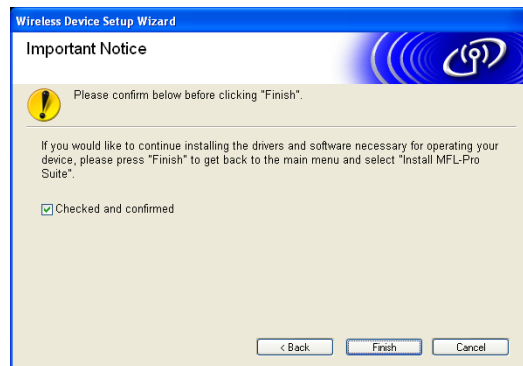

Configuration with an access point that supports SecureEasySetup™ or AOSS™

For Windows® 2000/XP or Windows Vista™

IMPORTANT

If you have previously configured the wireless settings of the machine, you must reset the network LAN settings before you can configure the wireless settings again. Press **Menu**, **▲** or **▼** for LAN, **Factory Reset** and select **Yes** to accept the change. The machine will restart automatically.

4

- 1 Turn on the machine by plugging in the power cord.

(For US)

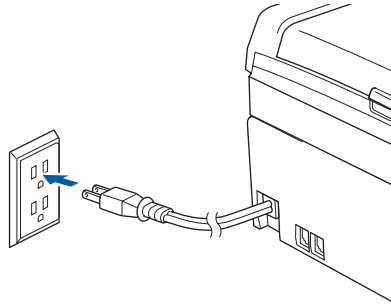

(For UK)

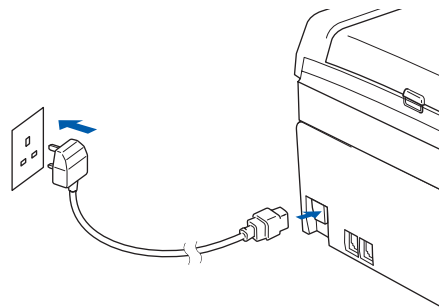

- 2 Turn on your computer.



Note

Before configuration, if you are using personal firewall software, disable it. Once you are sure that you can print after the installation, restart your personal firewall software.

- 3 Put the supplied CD-ROM into your CD-ROM drive. If the model name screen appears, choose your machine. If the language screen appears, choose your language.

- 4 The CD-ROM main menu will appear. Click **Install Other Drivers or Utilities**.
(For US)

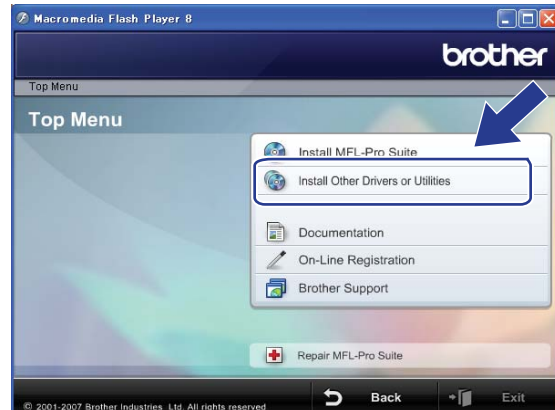

(For UK)

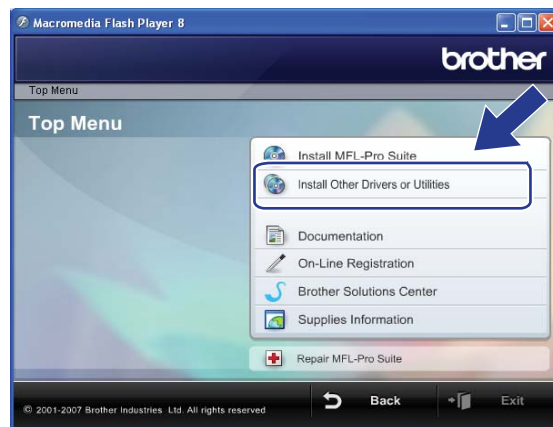

Note

If this window does not appear, use Windows® Explorer to run the start.exe program from the root folder of the Brother CD-ROM.

5 Click **Wireless LAN Setup Wizard**.

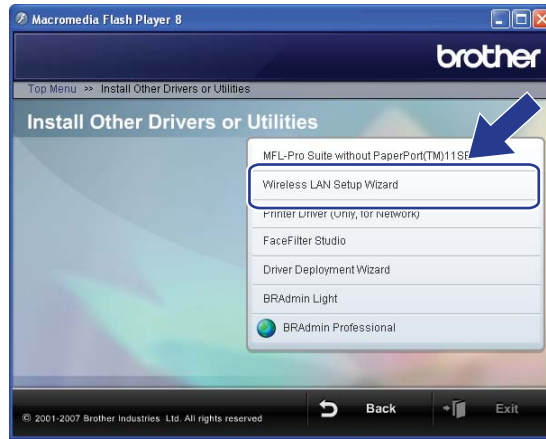

- 6 Make the following selection and click **Next**.

(For SecureEasySetup™)

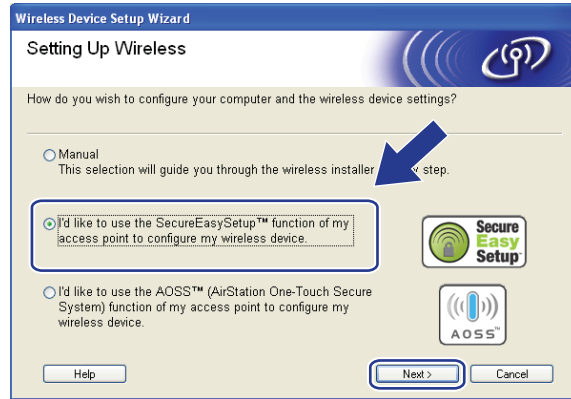

(For AOSS™)

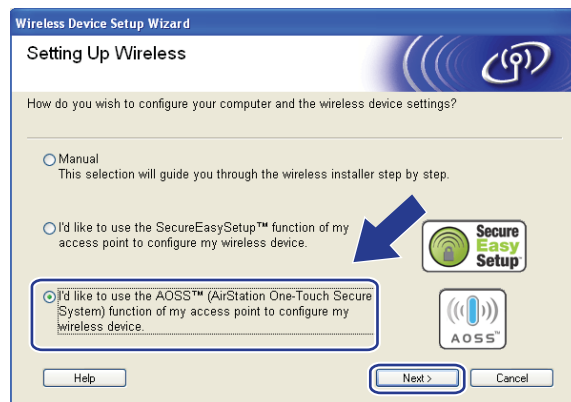

- 7 Read the **Important Notice** and click **Next**.

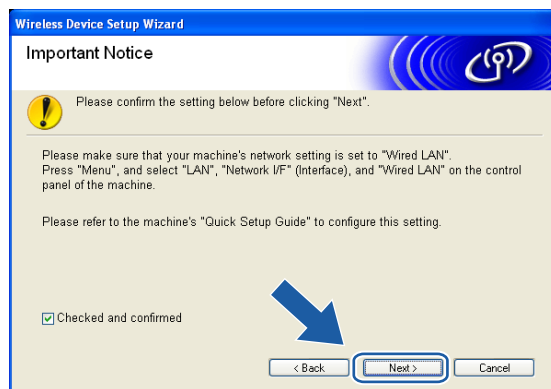

- 8 Confirm the on-screen message and click **Next**.

(For SecureEasySetup™)



(For AOSS™)

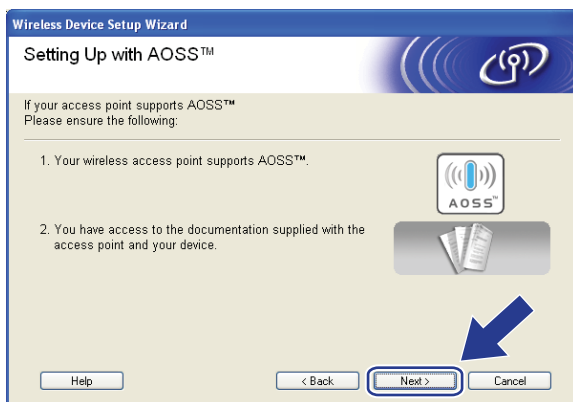

- 9 Refer to the instruction manual that came with your access point to set the SecureEasySetup™ or AOSS™ mode of your access point.
- 10 Put the machine in SecureEasySetup™ or AOSS™ mode. Press **Menu**, **▲** or **▼** for **LAN** and press **OK**. Press **▲** or **▼** for **WLAN** and then press **OK**. Press **▲** or **▼** for **SecureEasySetup** or **AOSS** and press **OK**.



Note

If the LCD shows **Connection Error (Connection Fail)**, please try again.

- 11 Click **Finish**.

(For SecureEasySetup™)

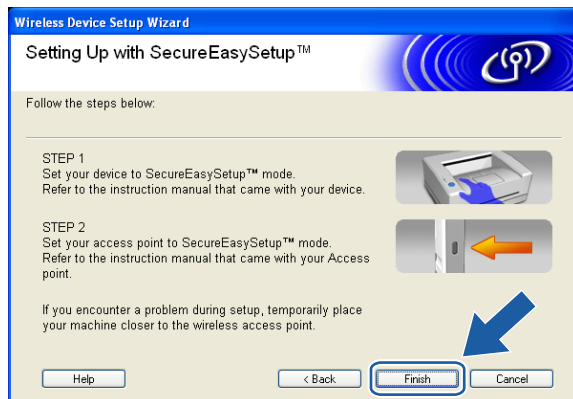

(For AOSS™)

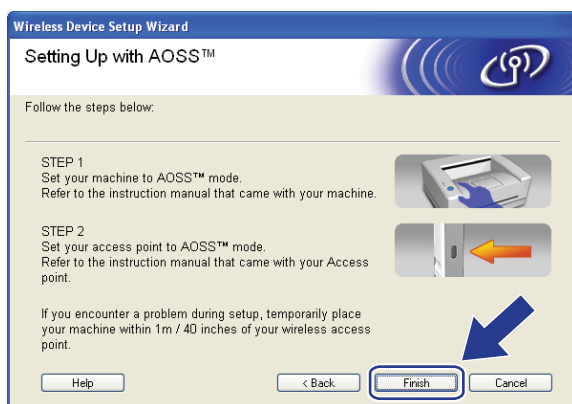

- 12 The configuration is finished. Relocate the machine to a location that is within range of your access point. You have completed the wireless setup. If you would like to continue installing drivers and software necessary for operating your device, please select **Install MFL-Pro Suite** from CD-ROM menu.

Configuration in Ad-hoc Mode

For Windows® 2000 Professional/XP or Windows Vista™

IMPORTANT

If you have previously configured the wireless settings of the machine, you must reset the network LAN settings before you can configure the wireless settings again. Press **Menu**, **▲** or **▼** for **LAN**, **Factory Reset** and select **Yes** to accept the change. The machine will restart automatically.

4

- 1 Turn on the machine by plugging in the power cord.

(For US)

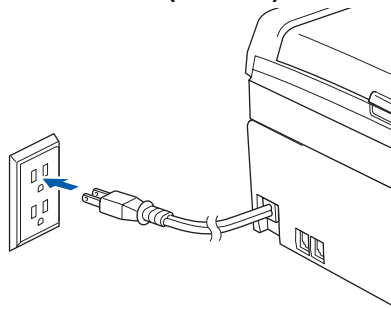

(For UK)

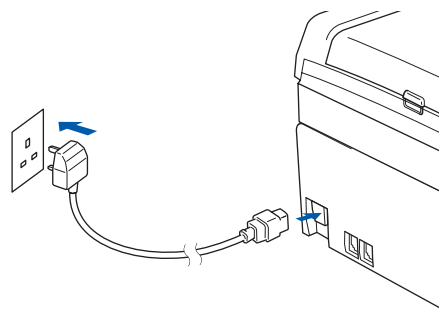

- 2 Turn on your computer.



Note

Before configuration, if you are using personal firewall software, disable it. Once you are sure that you can print after the installation, restart your personal firewall software.

- 3 Put the supplied CD-ROM into your CD-ROM drive. If the model name screen appears, choose your machine. If the language screen appears, choose your language.

- 4 The CD-ROM main menu will appear. Click **Install Other Drivers or Utilities**.
(For US)



(For UK)



Note

If this window does not appear, use Windows® Explorer to run the start.exe program from the root folder of the Brother CD-ROM.

- 5 Click **Wireless LAN Setup Wizard**.

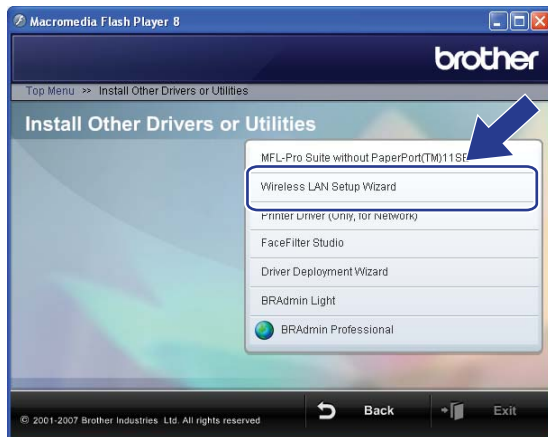

- 6 Choose **Manual** and then click **Next**.

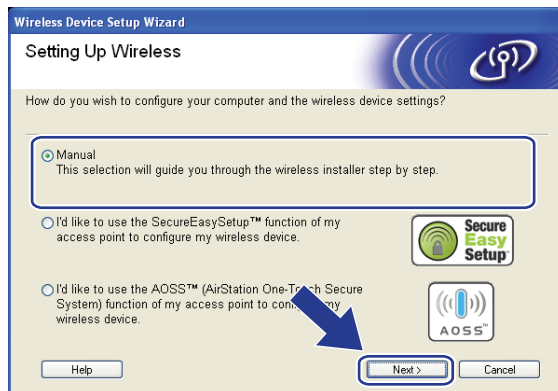

- 7 Choose **I'm not able to connect my device to my access point with a network cable**. Click **Next**.

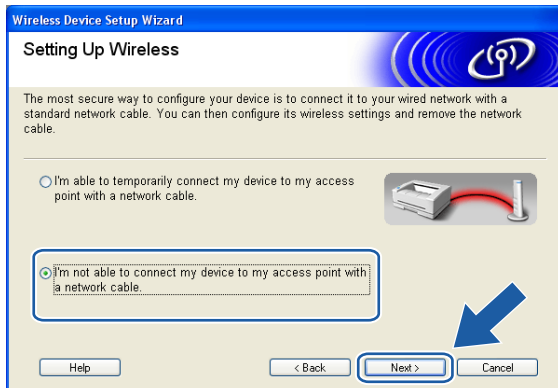

- 8 Choose **This PC has wireless capability**, and make sure **I am using an access point in infrastructure mode** is not checked. Click **Next**.

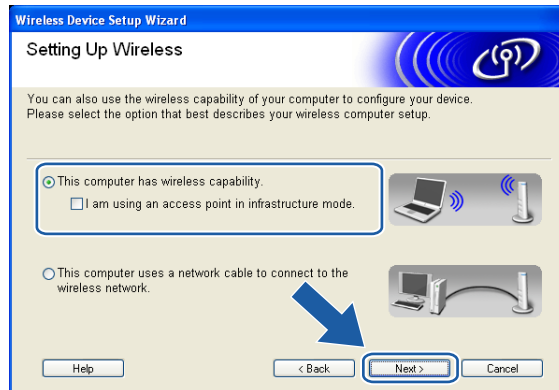

- 9 Read the **Important Notice** and click **Next**.

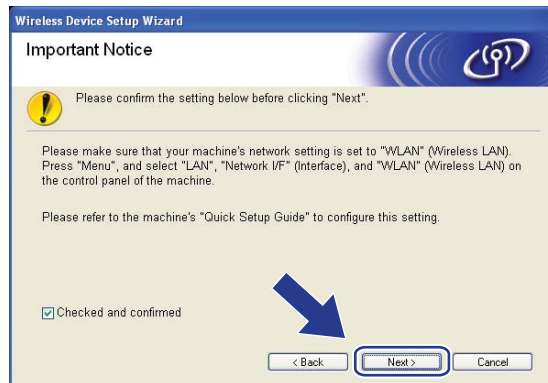

- 10 You need to temporarily change your PC's wireless settings. Please follow the on-screen instructions. Please make sure you take notes on all the settings such as SSID or channel of your PC. You will need them to return your PC back to its original wireless settings.

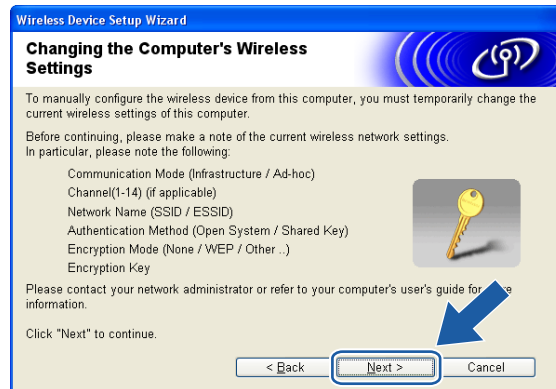

| Item | Record the current wireless computer settings |
|---|---|
| Communication mode:(Infrastructure/Ad-hoc) | |
| Channel: | |
| Network name(SSID/ESSID) | |
| Authentication method(Open system/Shared key) | |
| Encryption:(None/WEP/WPA/WPA2-PSK) | |
| Encryption key: | |

- 11 To communicate with the un-configured wireless machine, temporarily change the wireless settings on your PC to match machine's default settings shown on this screen. Click **Next**.



Note

- If a message to restart your PC appears after the wireless settings have been changed, restart your PC and then go back to step 4 and continue with the install skipping steps 9, 10 and 11.
- For Windows® XP SP2 users you can temporarily change the wireless settings on your PC, following the steps below:

- 1 Click **Start** and then **Control Panel**.
- 2 Click **Network Connections** icon.
- 3 Select and right click **Wireless Network Connection**. Click **View Available Wireless Networks**.
- 4 You can see the Brother wireless machine in the list. Select **SETUP** and click **Connect**.
- 5 Check the **Wireless Network Connection** status. It may take a few minutes to change from 0.0.0.0 to 169.254.x.x IP address to be shown on screen (where x.x. are numbers between 1 and 254).

- For Windows Vista™ users:

You can temporarily change the wireless settings on your computer, following the steps below:

- 1 Click **Start** and then **Control Panel**.
- 2 Click **Network and Internet** and then **Network and Sharing Center** icon.
- 3 Click **Connect to a network**.
- 4 You can see the SSID of the wireless printer in the list. Select **SETUP** and click **Connect**.
- 5 Click **Connect Anyway** and then **Close**.
- 6 Click **View status** of **Wireless Network Connection (SETUP)**.
- 7 Click **Details...** and check the **Network Connection Details**. It may take a few minutes to change from 0.0.0.0 to 169.254.x.x IP address to be shown on screen (where x.x. are numbers between 1 and 254).

- 12 The following list appears. If the list is blank, check if the machine is powered on, and then click **Refresh**. Choose the machine you wish to configure, and click **Next**.



Note

The Default Node name of the NC-xxxx (where "xxxx" is your model name) is "BRWxxxxxxxxxxxx" (where "xxxxxxxxxxxx" is your Ethernet address).

- 13 The wizard will search for wireless networks available from your machine. Choose the Ad-hoc network you wish to associate the machine with, and then click **Next**. If no Ad-hoc wireless networks are available, you need to create a new wireless network. Go to 16.

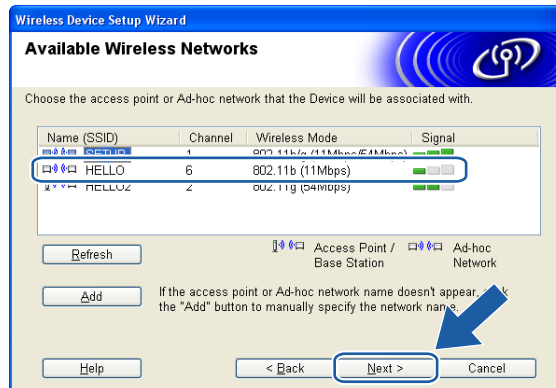

 **Note**

- If your target Ad-hoc network is not broadcasting the SSID name and does not appear on the list, you can manually add it by clicking the **Add** button. Follow the on-screen instructions for entering the **Name (SSID)** and the **Channel** number.
- If the list is blank, check if the machine is within range for wireless communication. Then, click **Refresh**.

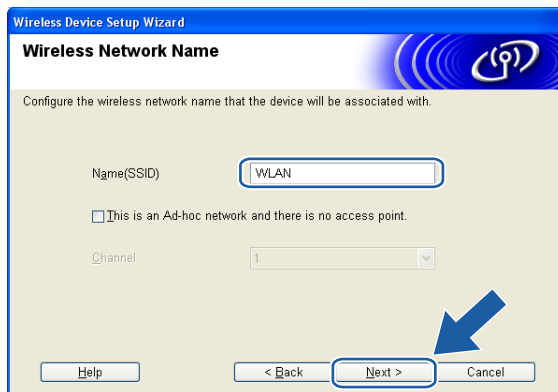

- 14 If your network is not configured for Authentication and Encryption, the following screen will appear. To continue configuration, click **OK** and go to 17.



- 15 If your network is configured for Authentication and Encryption, the following screen will appear. When configuring your Brother wireless machine, you must ensure that it is configured to match the Authentication and Encryption settings of your existing wireless network. Choose the **Authentication Method** and **Encryption Mode** from the pull-downs in each setting box. Then enter the **Network key** and click **Next**. Go to 17.

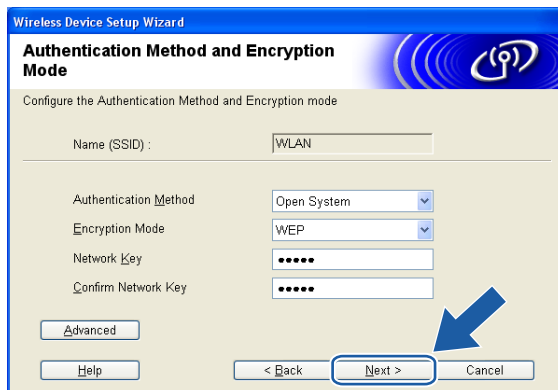

 **Note**

- If you want to set more than one WEP key, click **Advanced**.
- If you do not know the Authentication or Encryption settings for network, contact your network administrator.

- 16** Enter a new SSID name and choose the **Authentication Method** and **Encryption Mode** from the pull-downs in each setting box. Then enter the **Network key** and click **Next**.



Wireless Device Setup Wizard

Wireless Network Settings

Specify the Wireless Network name:

Name (SSID) HELLO

Channel 1

Authentication Method Open System

Encryption Mode None

Network Key

Confirm Network Key

Next > Cancel

 **Note**

If you do not know the Authentication or Encryption settings for network, contact your network administrator.

- 17** Click **Next**. The settings will be sent to your machine. The settings will remain unchanged if you click **Cancel**.

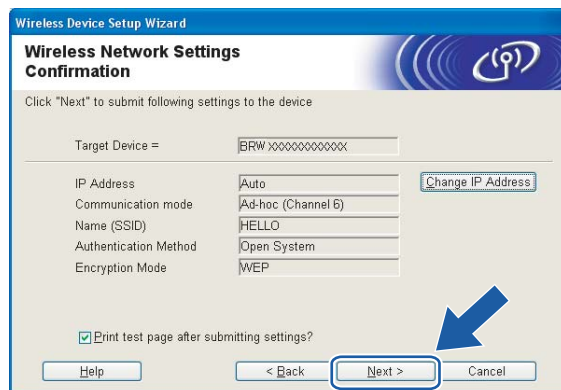

Wireless Device Setup Wizard

Wireless Network Settings Confirmation

Click "Next" to submit following settings to the device

Target Device = BRWXXXXXXXXXXXX

IP Address Auto [Change IP Address](#)

Communication mode Ad-hoc (Channel 6)

Name (SSID) HELLO

Authentication Method Open System

Encryption Mode WEP

Print test page after submitting settings?

Help < Back Next > Cancel

 **Note**

If you want to manually enter the IP address settings of your machine, click **Change IP Address** and enter the necessary IP address settings for your network. After making your selection, click **Next** and the Wizard will search for available wireless networks.

- 18 To communicate with the configured wireless device, you must configure your PC to use same wireless settings. Manually change the wireless settings on your PC to match the machine's wireless settings shown on this screen. Click **Next**.
(The settings shown on this screen are for example only. Your settings will not be the same.)

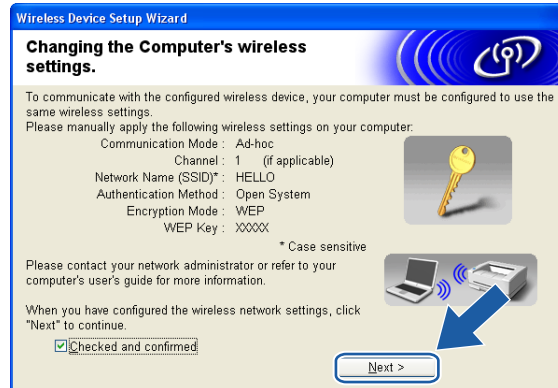

- 19 You have completed the wireless setup. Click **Finish**. If you would like to continue installing drivers and software necessary for operating your device, please select **Install MFL-Pro Suite** from CD-ROM menu.



5

Wireless Configuration for Macintosh®

Configuration in Infrastructure mode

For Mac OS® X 10.2.4 or greater

IMPORTANT

If you have previously configured the wireless settings of the machine, you must reset the network LAN settings before you can configure the wireless settings again. Press **Menu**, **▲** or **▼** for **LAN**, **Factory Reset** and select **Yes** to accept the change. The machine will restart automatically.

- 1 Turn on the machine by plugging in the power cord.

(For US)

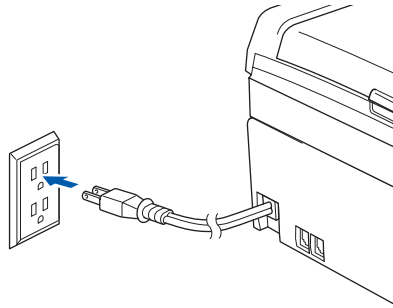

(For UK)

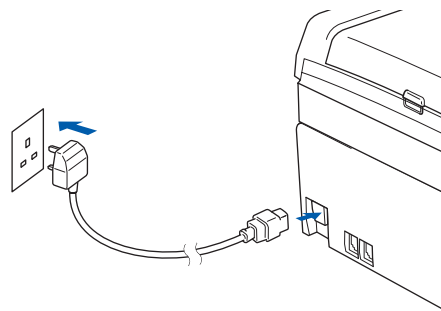

- 2 Turn on your Macintosh®.
- 3 Put the supplied CD-ROM into your CD-ROM drive.

- 4 Double-click the **Utilities** icon and then **Wireless Device Setup Wizard**.

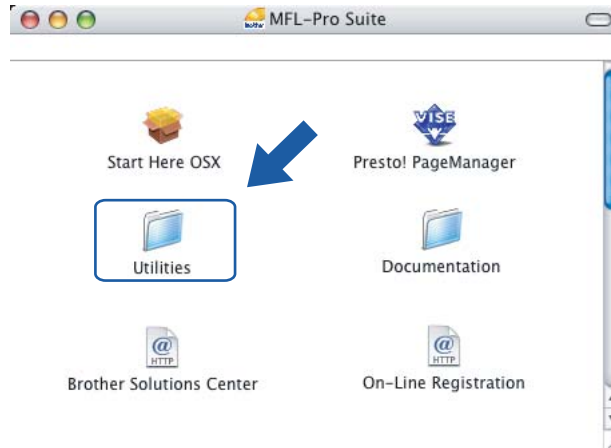

- 5 Choose **Manual** and then click **Next**.



6 For configuration, it is recommended that you temporarily connect your Brother wireless device directly to a free port on your access point, hub or router using a network cable.

- If you can temporarily connect with a network cable:

Choose **I'm able to temporarily connect my device to my access point with a network cable** and then click **Next**.

Go to 7.

- If you do not have a network cable or cannot temporarily connect the Brother wireless device to your access point:

Choose **I'm not able to connect my device to my access point with a network cable** and then click **Next**.

Go to 9.

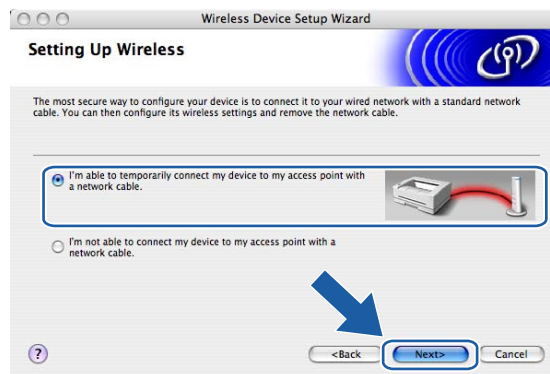

7 Read the **Important Notice** and click **Next**.

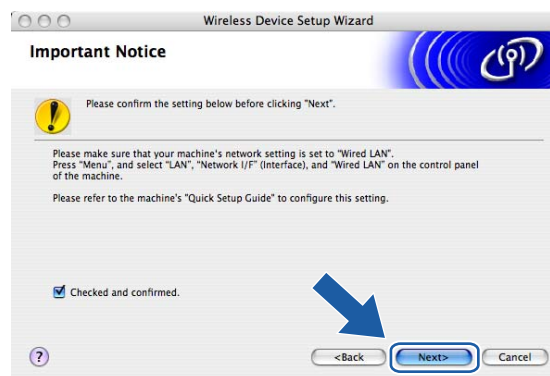

- 8 Connect the Brother wireless device to your access point using a network cable and click **Next**. Go to 13

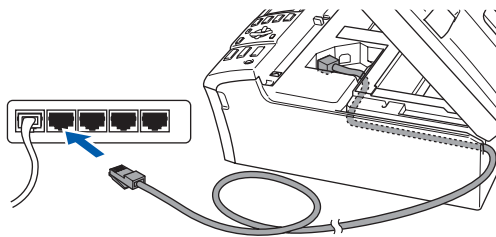
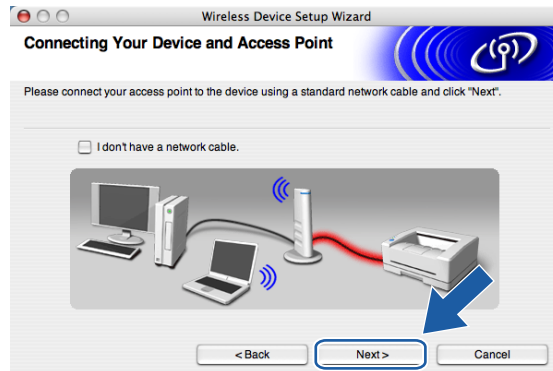

- 9 If you choose **This computer has wireless capability**, check **I am using an access point in infrastructure mode**, and then click **Next**. Go to 10



If you are using a wired computer, choose **This computer uses a network cable to connect to the wireless network.**, you must configure the wireless settings from the control panel. Click **Next** and follow the on-screen instructions to complete the setup. See *Using the Setup Wizard from the control panel* on page 22.



- 10 Read the **Important Notice** and click **Next**.



- 11 You need to temporarily change your computer's wireless settings. Please follow the on-screen instructions. Please make sure you take notes on all the settings such as SSID or channel of your computer. You will need them to return your PC back to its original wireless settings.

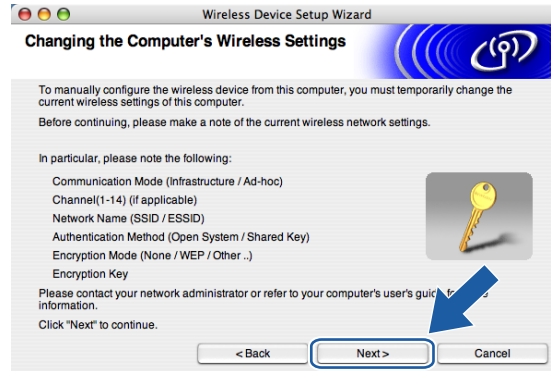

| Item | Record the current wireless computer settings |
|---|---|
| Communication mode:(Infrastructure/Ad-hoc) | |
| Channel: | |
| Network name(SSID/ESSID) | |
| Authentication method(Open system/Shared key) | |
| Encryption:(None/WEP/WPA/WPA2-PSK) | |
| Encryption key: | |

- 12 To communicate with the un-configured wireless machine, temporarily change the wireless settings on your computer to match machine's default settings shown on this screen. Click **Next**.

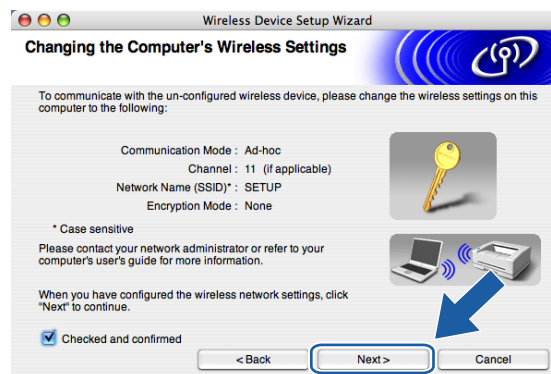

- 13 The following list appears. If the list is blank, check if the access point and the machine are powered on, and then click **Refresh**. Choose the machine you wish to configure, and click **Next**.

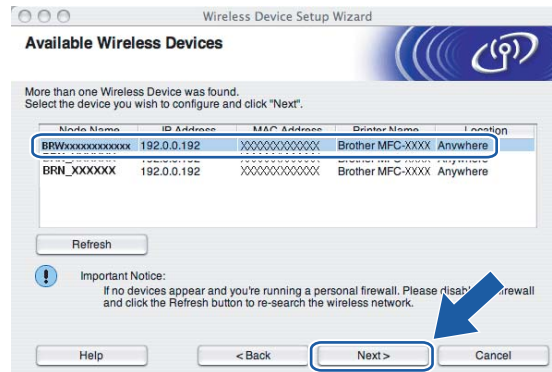

Note

The Default Node name of the NC-xxxx (where “xxxx” is your model name) is “BRNxxxxxxxxxxxx” or “BRWxxxxxxxxxxxx” (where “xxxxxxxxxxxx” is your Ethernet address).

- 14 The wizard will search for wireless networks available from your machine. Choose the access point you wish to associate the machine with, and then click **Next**.

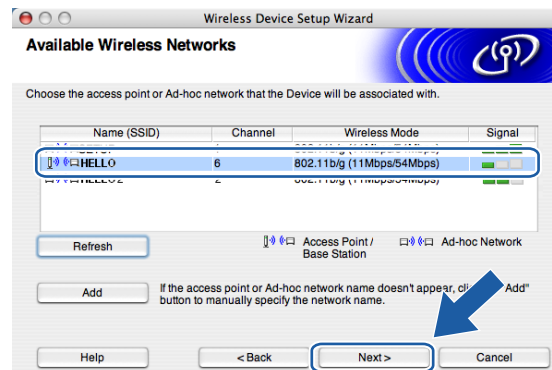

 **Note**

- If your access point is set to not broadcast the SSID you can manually add it by clicking the **Add** button. Follow the on-screen instructions for entering the **Name (SSID)** and the Channel number.
- If the list is blank, check that the access point has power and is broadcasting the SSID, and then see if the machine and the access point are within range for wireless communication. Then, click **Refresh..**
- "SETUP" is the default SSID of the machine. Do not choose this SSID.

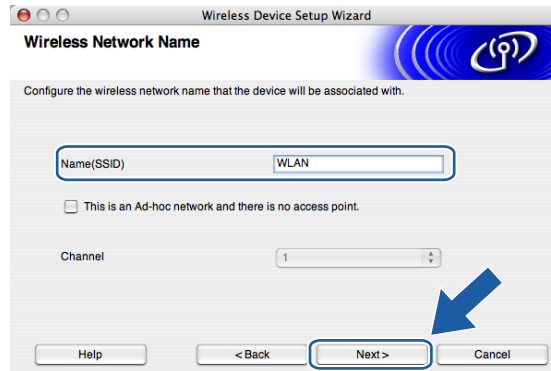

- 15 If your network is not configured for Authentication and Encryption, the following screen will appear. To continue installation, click **OK** and go to 17.



- 16 If your network is configured for Authentication and Encryption, the following screen will appear. When configuring your Brother wireless machine, you must ensure that it is configured to match the Authentication and Encryption settings of your existing wireless network. Choose the **Authentication Method** and **Encryption Mode** from the pull-downs in each setting box. Then enter the **Network key** and click **Next**.

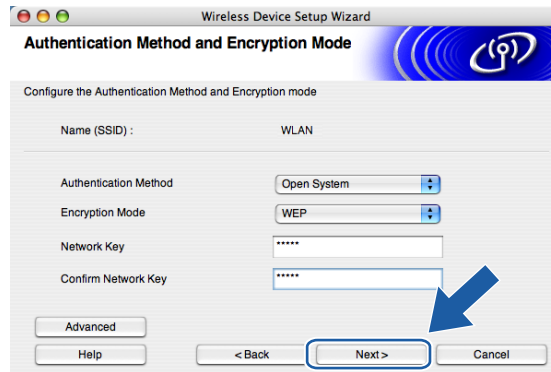

Note

- If you want to set more than one WEP key, click **Advanced**.
- If you do not know the Authentication or Encryption settings for network, contact your network administrator.

- 17 Click **Next**. The settings will be sent to your machine. The settings will remain unchanged if you click **Cancel**.

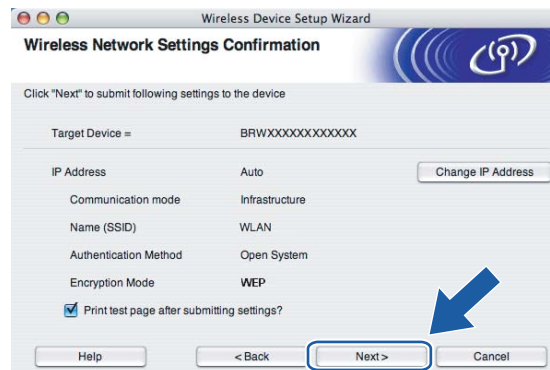

Note

- If you want to manually enter the IP address settings of your machine, click **Change IP Address** and enter the necessary IP address settings for your network.
- The control panel settings will be automatically changed to `WLAN` when the wireless settings are sent to your machine.

- 18 If you choose **I'm able to temporarily connect my device to my access point with a network cable** in step 6;

Disconnect the network cable between your access point (hub or router) and the machine, and click **Next**. Go to 20.

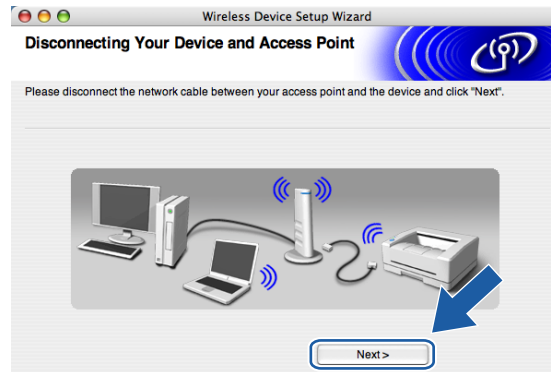

- 19 If you choose **This computer has wireless capability** in step 9; Using the information you recorded in 11, return the wireless settings of your computer back to their original settings. Click **Next**.



- 20 You have completed the wireless setup. Click **Finish**. If you would like to continue installing drivers and software necessary for operating your device, please select **Start Here OSX** from CD-ROM menu.

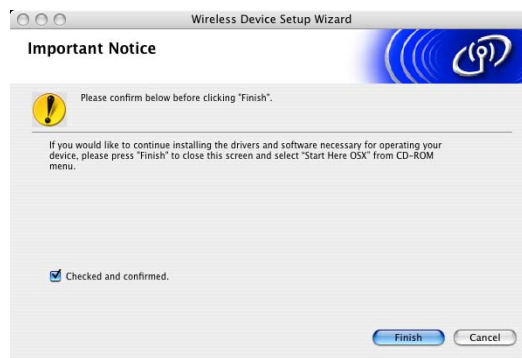

Configuration with an access point that supports SecureEasySetup™ or AOSS™

For Mac OS® X 10.2.4 or greater

IMPORTANT

If you have previously configured the wireless settings of the machine, you must reset the network LAN settings before you can configure the wireless settings again. Press **Menu**, **▲** or **▼** for **LAN**, **Factory Reset** and select **Yes** to accept the change. The machine will restart automatically.

- 1 Turn on the machine by plugging in the power cord.

(For US)

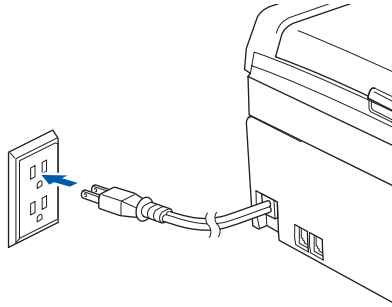

(For UK)

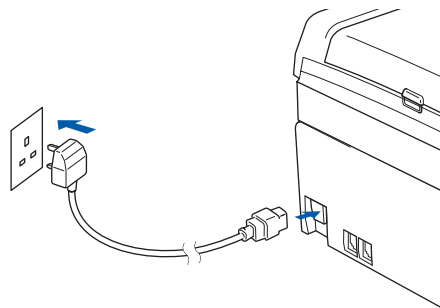

- 2 Turn on your Macintosh®.
- 3 Put the supplied CD-ROM into your CD-ROM drive.

- 4 Double-click the **Utilities** icon and then **Wireless Device Setup Wizard**.

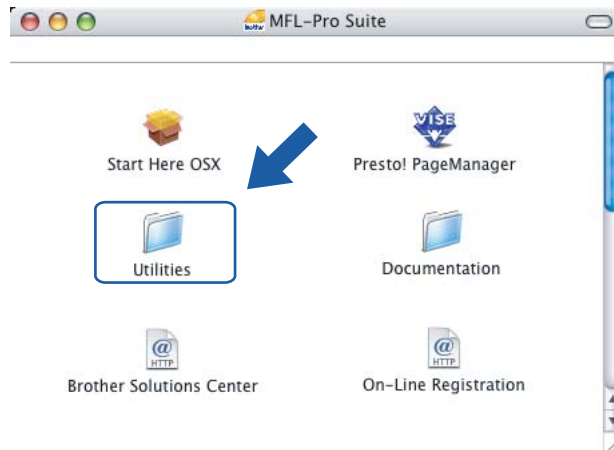

- 5 Make the following selection and click **Next**.

(For SecureEasySetup™)



(For AOSS™)

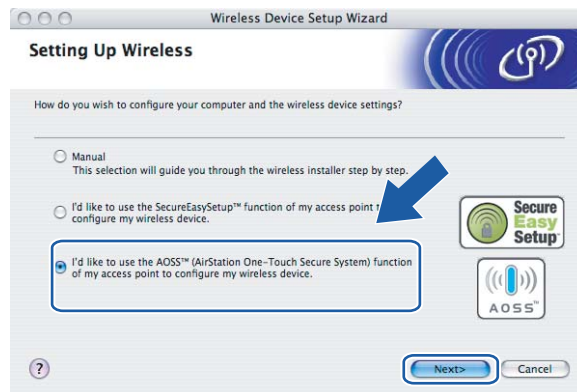

- 6 Read the **Important Notice** and click **Next**.

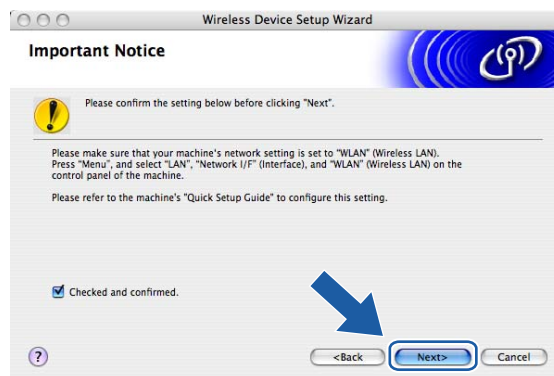

- 7 Confirm the on-screen message and click **Next**.

(For SecureEasySetup™)



(For AOSS™)



- 8 Refer to the instruction manual that came with your access point to set the SecureEasySetup™ or AOSS™ mode of your access point.
- 9 Put the machine in SecureEasySetup™ or AOSS™ mode. Press **Menu**, **▲** or **▼** for **LAN** and press **OK**. Press **▲** or **▼** for **WLAN** and then press **OK**. Press **▲** or **▼** for **SecureEasySetup** or **AOSS** and press **OK**.



Note

If the LCD shows `Connection Error (Connection Fail)`, please try again.

- 10 Click **Finish**.

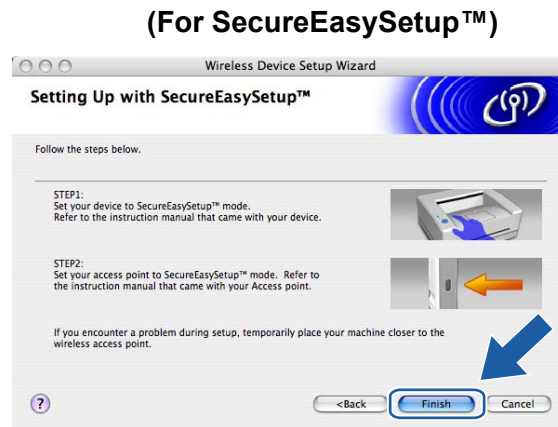

5

- 11 The configuration is finished. Relocate the machine to a location that is within range of your access point. You have completed the wireless setup. If you would like to continue installing drivers and software necessary for operating your device, please select **Start Here OSX** from CD-ROM menu.

Configuration in Ad-hoc Mode

For Mac OS® X 10.2.4 or greater

IMPORTANT

If you have previously configured the wireless settings of the machine, you must reset the network LAN settings before you can configure the wireless settings again. Press **Menu**, **▲** or **▼** for **LAN**, **Factory Reset** and select **Yes** to accept the change. The machine will restart automatically.

- 1 Turn on the machine by plugging in the power cord.

(For US)

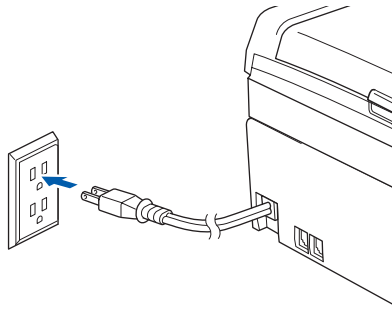

(For UK)

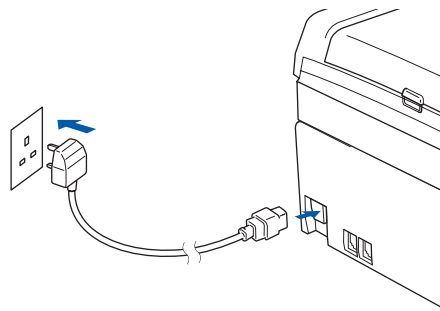

- 2 Turn on your Macintosh®.
- 3 Put the supplied CD-ROM into your CD-ROM drive.

- 4 Double-click the **Utilities** icon and then **Wireless Device Setup Wizard**.

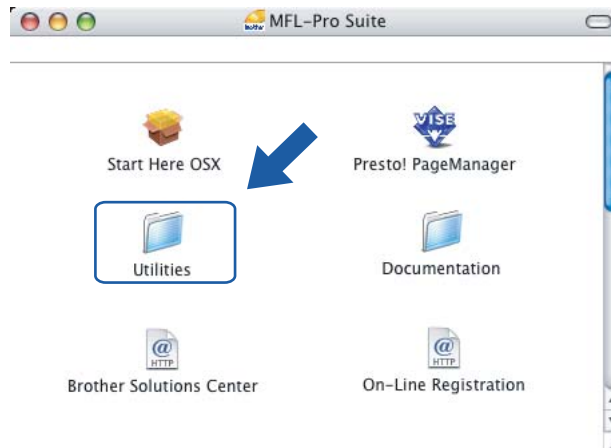

- 5 Choose **Manual** and then click **Next**.



- 6 Choose **I'm not able to connect my device to my access point with a network cable**. Click **Next**.



- 7 Choose **This computer has wireless capability**, and make sure **I am using an access point in infrastructure mode** is not checked. Click **Next**.

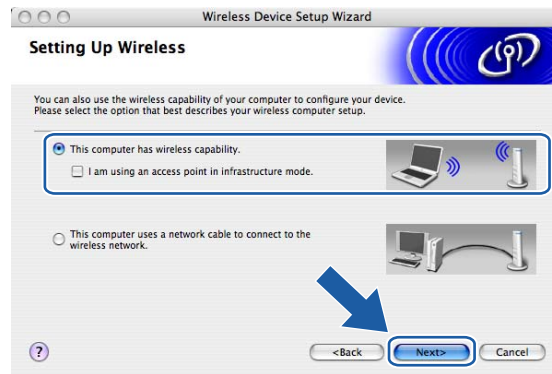

- 8 Read the **Important Notice** and click **Next**.

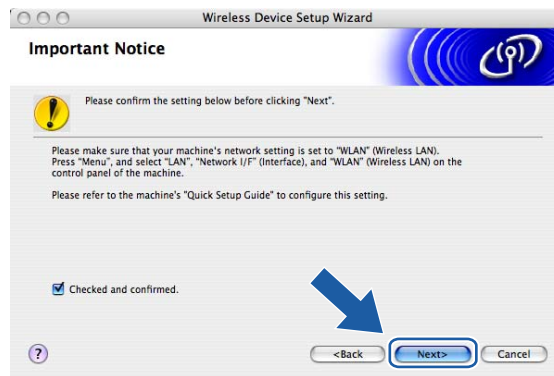

- 9 You need to temporarily change your computer’s wireless settings. Please follow the on-screen instructions. Please make sure you take notes on all the settings such as SSID or channel of your computer. You will need them to return your computer back to its original wireless settings.

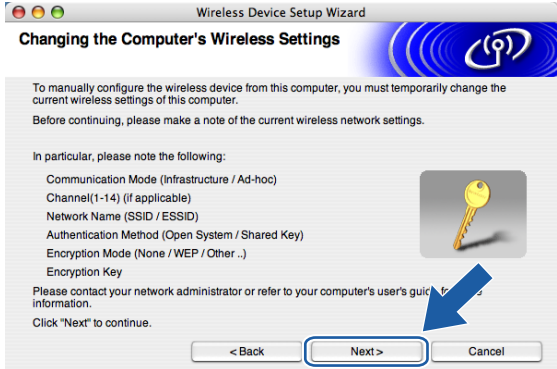

5

| Item | Record the current wireless computer settings |
|---|---|
| Communication mode:(Infrastructure/Ad-hoc) | |
| Channel: | |
| Network name(SSID/ESSID) | |
| Authentication method(Open system/Shared key) | |
| Encryption:(None/WEP/WPA/WPA2-PSK) | |
| Encryption key: | |

- 10 To communicate with the un-configured wireless machine, temporarily change the wireless settings on your computer to match machine’s default settings shown on this screen. Click **Next**.

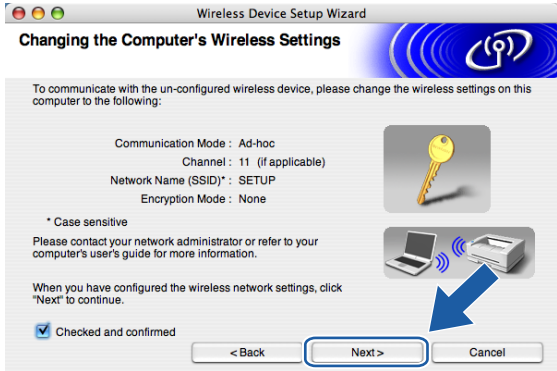

- 11 The following list appears. If the list is blank, check if the machine is powered on, and then click **Refresh**. Choose the machine you wish to configure, and click **Next**.

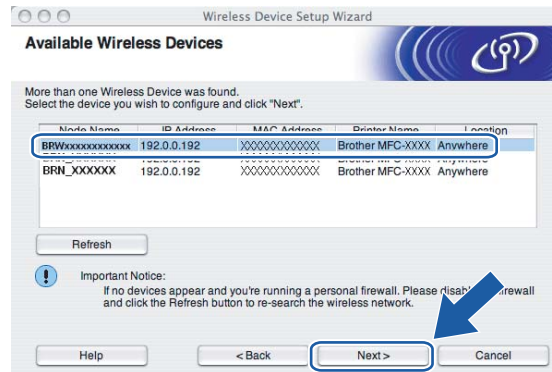

Note

The Default Node name of the NC-xxxx (where "xxxx" is your model name) is "BRWxxxxxxxxxxxx" (where "xxxxxxxxxxxx" is your Ethernet address).

- 12 The wizard will search for wireless networks available from your machine. Choose the Ad-hoc network you wish to associate the machine with, and then click **Next**.
If no Ad-hoc wireless networks are available, you need to create a new wireless network. Go to 15.

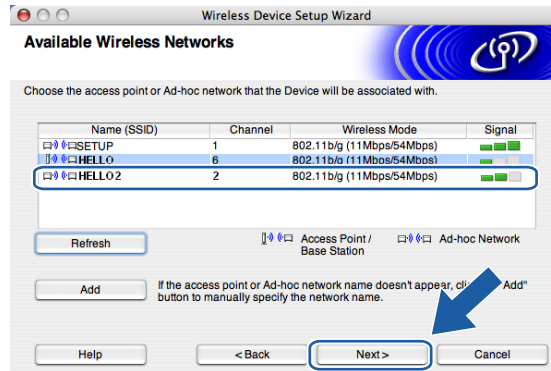

Note

- If your target Ad-hoc network is not broadcasting the SSID name and does not appear on the list, you can manually add it by clicking the **Add** button. Follow the on-screen instructions for entering the **Name (SSID)** and the **Channel** number.
- If the list is blank, check if the machine is within range for wireless communication. Then, click **Refresh**.

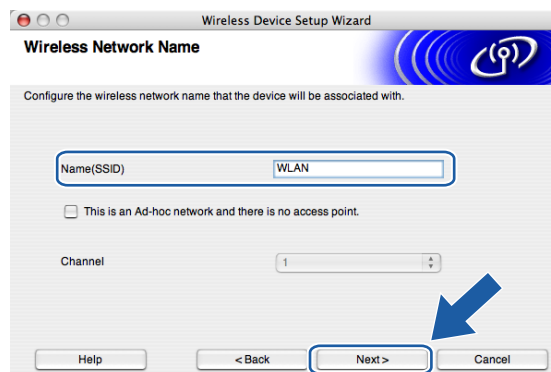

- 13 If your network is not configured for Authentication and Encryption, the following screen will appear. To continue installation, click **OK** and go to 16.



- 14 If your network is configured for Authentication and Encryption, the following screen will appear. When configuring your Brother wireless machine, you must ensure that it is configured to match the Authentication and Encryption settings of your existing wireless network. Choose the **Authentication Method** and **Encryption Mode** from the pull-downs in each setting box. Then enter the **Network key** and click **Next**. Go to step 16.

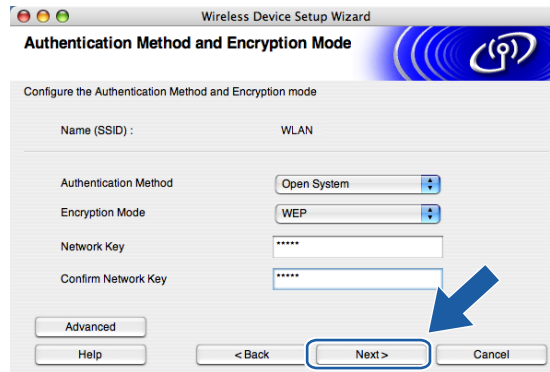

 **Note**

- If you want to set more than one WEP key, click **Advanced**.
- If you do not know the Authentication or Encryption settings for network, contact your network administrator.

- 15 Enter a new SSID name and choose the **Authentication Method** and **Encryption Mode** from the pull-downs in each setting box. Then enter the **Network key** and click **Next**.

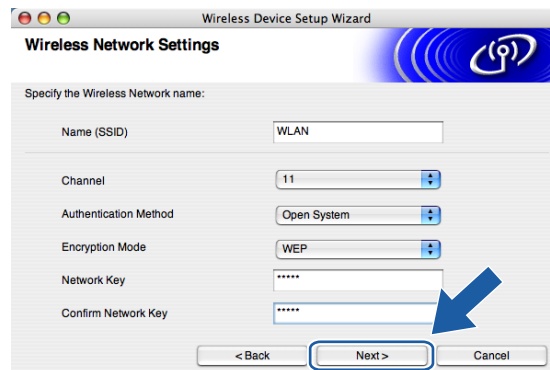

 **Note**

If you do not know the Authentication or Encryption settings for network, contact your network administrator.

- 16 Click **Next**. The settings will be sent to your machine. The settings will remain unchanged if you click **Cancel**.

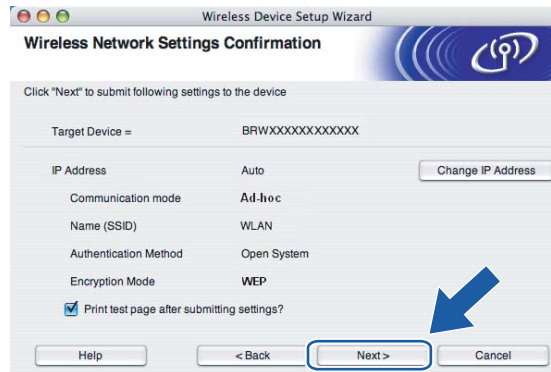

Note

If you want to manually enter the IP address settings of your machine, click **Change IP Address** and enter the necessary IP address settings for your network.

- 17 To communicate with the configured wireless device, you must configure your computer to use same wireless settings. Manually change the wireless settings on your computer to match the machine's wireless settings shown on this screen. Click **Next**.
(The settings shown on this screen are for example only. Your settings will not be the same.)

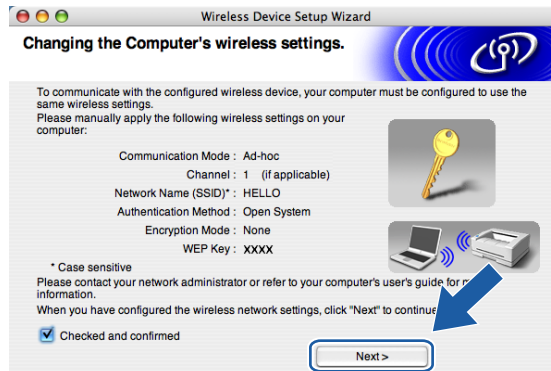

- 18 You have completed the wireless setup. Click **Finish**. If you would like to continue installing drivers and software necessary for operating your device, please select **Start Here OSX** from CD-ROM menu.



LAN menu

Before using your Brother product in a network environment, you need to configure the correct TCP/IP settings.

In this chapter, you will learn how to configure the network settings using the control panel, located on the front of the machine.

The LAN menu selections of the control panel allow you to set up the Brother machine for your network configuration. Press **Menu**, then press **▲** or **▼** to select **LAN**. Proceed to the menu selection you wish to configure. See *Function table and default factory settings* on page 122.

Please note that the machine is supplied with the BRAdmin Light Windows[®] software and Remote Setup applications for Windows[®] and Macintosh[®], which also can be used to configure many aspects of the network. See *Using the Remote Setup to change the print server settings (Not available for DCP models)* on page 16 a for wired connection or *Changing the print server settings* on page 26 for a wireless connection.

Wired LAN TCP/IP / WLAN TCP/IP

If you connect the machine with the Ethernet cable to your network, use the **Wired LAN** menu selections. If you connect the machine to a wireless Ethernet network, use the **WLAN** menu selections.

This menu has nine sections: **BOOT Method**, **IP Address**, **Subnet Mask**, **Gateway**, **Node Name**, **WINS Config**, **WINS Server**, **DNS Server** and **APIPA**.

BOOT Method

This selection controls how the machine obtains an IP address. The default setting is **Auto**.



Note

If you do not want your print server configured via DHCP, BOOTP or RARP, you must set the **BOOT Method** to **Static** so that the print server has a static IP address. This will prevent the print server from trying to obtain an IP address from any of these systems. To change the **BOOT Method**, use the machine's control panel, BRAdmin Light utility or Remote Setup.

- 1 Press **Menu**.
- 2 Press **▲** or **▼** to select **LAN**.
Press **OK**.
- 3 (For Wired) Press **▲** or **▼** to select **Wired LAN**.
(For Wireless) Press **▲** or **▼** to select **WLAN**.
Press **OK**.
- 4 Press **▲** or **▼** to select **TCP/IP**.
Press **OK**.

- 5 Press ▲ or ▼ to select `BOOT Method`. Press **OK**.
- 6 Press ◀ or ▶ to select `Auto`, `Static`, `RARP`, `BOOTP` or `DHCP`. Press **OK**.
- 7 Press **Stop/Exit**.

Auto mode

In this mode, the machine will scan the network for a DHCP server, if it can find one, and if the DHCP server is configured to allocate an IP address to the machine, then the IP address supplied by the DHCP server will be used. If no DHCP server is available, then the machine will scan for a BOOTP server. If a BOOTP server is available, and it is configured correctly, the machine will take its IP address from the BOOTP server. If a BOOTP server is not available, the machine will scan for a RARP server. If a RARP server also does not answer, the IP Address is scanned through APIPA facility, see *Using APIPA to configure the IP address* on page 114. After it is initially powered ON, it may take a few minutes for the machine to scan the network for a server.

Static mode

In this mode the machine's IP address must be manually assigned. Once entered the IP address is locked to the assigned address.

RARP mode

The Brother print server IP address can be configured using the Reverse ARP (RARP) service on your host computer. This is done by editing the `/etc/ethers` file (if this file does not exist, you can create it) with an entry similar to the following:

```
00:80:77:31:01:07 BRN008077310107 (or BRW008077310107 for a wireless network)
```

Where the first entry is the Ethernet address of the print server and the second entry is the name of the print server (the name must be the same as the one you put in the `/etc/hosts` file).

If the `rarp` daemon is not already running, start it (depending on the system the command can be `rarpd`, `rarpd -a`, `in.rarpd -a` or something else; type `man rarpd` or refer to your system documentation for additional information). To verify that the `rarp` daemon is running on a Berkeley UNIX[®] based system, type the following command:

```
ps -ax | grep -v grep | grep rarpd
```

For AT&T UNIX[®] based systems, type:

```
ps -ef | grep -v grep | grep rarpd
```

The Brother print server will get the IP address from the `rarp` daemon when it is powered on.

BOOTP mode

BOOTP is an alternative to `rarp` that has the advantage of allowing configuration of the subnet mask and gateway. In order to use BOOTP to configure the IP address make sure that BOOTP is installed and running on your host computer (it should appear in the `/etc/services` file on your host as a real service; type `man bootpd` or refer to your system documentation for information). BOOTP is usually started up via the

/etc/inetd.conf file, so you may need to enable it by removing the “#” in front of the bootpd entry in that file. For example, a typical bootpd entry in the /etc/inetd.conf file would be:

```
#bootpd dgram udp wait /usr/etc/bootpd bootpd -i
```



Note

Depending on the system, this entry might be called “bootps” instead of “bootpd”.

In order to enable BOOTP, simply use an editor to delete the “#” (if there is no “#”, then BOOTP is already enabled). Then edit the BOOTP configuration file (usually /etc/bootptab) and enter the name, network type (1 for Ethernet), Ethernet address and the IP address, subnet mask and gateway of the print server. Unfortunately, the exact format for doing this is not standardized, so you will need to refer to your system documentation to determine how to enter this information (many UNIX[®] systems also have template examples in the bootptab file that you can use for reference). Some examples of typical /etc/bootptab entries include: (“BRN” below is “BRW” for a wireless network.)

```
BRN008077310107 1 00:80:77:31:01:07 192.189.207.3
```

and:

```
BRN008077310107:ht=ethernet:ha=008077310107:\
ip=192.189.207.3:
```

Certain BOOTP host software implementations will not respond to BOOTP requests if you have not included a download filename in the configuration file; if this is the case, simply create a null file on the host and specify the name of this file and its path in the configuration file.

As with rarp, the print server will load its IP address from the BOOTP server when the printer is powered on.

DHCP mode

Dynamic Host Configuration Protocol (DHCP) is one of several automated mechanisms for IP address allocation. If you have a DHCP server in your network (typically a UNIX[®], Windows[®] 2000/XP or Windows Vista™ network) the print server will automatically obtain its IP address from a DHCP server and register its name with any RFC 1001 and 1002 compliant dynamic name services.

IP Address

This field displays the current IP address of the machine. If you have selected a BOOT Method of Static, enter the IP address that you wish to assign to the machine (check with your network administrator for the IP address to use). If you have selected a method other than Static, the machine will attempt to determine its IP address using the DHCP or BOOTP protocols. The default IP address of your machine will probably be incompatible with the IP address numbering scheme of your network. We recommend that you contact your network administrator for an IP address for the network the unit will be connected on.

- 1 Press **Menu**.
- 2 Press **▲** or **▼** to select LAN.
Press **OK**.
- 3 (For Wired) Press **▲** or **▼** to select `Wired LAN`.
(For Wireless) Press **▲** or **▼** to select `WLAN`.

Press **OK**.

- 4 Press ▲ or ▼ to select `TCP/IP`.
Press **OK**.
- 5 Press ▲ or ▼ to select `IP Address`.
Press **OK**.
- 6 Enter the IP address.
Press **OK**.



Note

For DCP models, press ▲ or ▼ repeatedly to enter the first three-digit number for the IP address. Press ► to enter the second three-digit number. Repeat this step until you have entered the fourth three-digit number to complete the IP address. Press **OK**.

- 7 Press **Stop/Exit**.

Subnet Mask

This field displays the current subnet mask used by the machine. If you are not using DHCP or BOOTP to obtain the subnet mask, enter the desired subnet mask. Check with your network administrator for the subnet mask to use.

- 1 Press **Menu**.
- 2 Press ▲ or ▼ to select `LAN`.
Press **OK**.
- 3 (For Wired) Press ▲ or ▼ to select `Wired LAN`.
(For Wireless) Press ▲ or ▼ to select `WLAN`.
Press **OK**.
- 4 Press ▲ or ▼ to select `TCP/IP`.
Press **OK**.
- 5 Press ▲ or ▼ to select `Subnet Mask`.
Press **OK**.
- 6 Enter the Subnet Mask address.
Press **OK**.



Note

For DCP models, press ▲ or ▼ repeatedly to enter the first three-digit number for the Subnet Mask. Press ► to enter the second three-digit number. Repeat this step until you have entered the fourth three-digit number to complete the Subnet Mask. Press **OK**.

- 7 Press **Stop/Exit**.

Gateway

This field displays the current gateway or router address used by the machine. If you are not using DHCP or BOOTP to obtain the gateway or router address, enter the address you wish to assign. If you do not have a gateway or router, leave this field blank. Check with your network administrator if you are unsure.

- 1 Press **Menu**.
- 2 Press **▲** or **▼** to select LAN.
Press **OK**.
- 3 (For Wired) Press **▲** or **▼** to select Wired LAN.
(For Wireless) Press **▲** or **▼** to select WLAN.
Press **OK**.
- 4 Press **▲** or **▼** to select TCP/IP.
Press **OK**.
- 5 Press **▲** or **▼** to select Gateway.
Press **OK**.
- 6 Enter the Gateway address.
Press **OK**.



Note

For DCP models, press **▲** or **▼** repeatedly to enter the first three-digit number for the Gateway address. Press **▶** to enter the second three-digit number. Repeat this step until you have entered the fourth three-digit number to complete the Gateway address. Press **OK**.

- 7 Press **Stop/Exit**.

Node Name

You can register the machine name on the Network. This name is often referred to as a NetBIOS name; it will be the name that is registered by the WINS server on your network. Brother recommends the name BRNxxxxxxxxxxx for a wired network or BRWxxxxxxxxxxx for a wireless network (where xxxxxxxxxxxx is your machine's Ethernet address) (up to 15 characters).

- 1 Press **Menu**.
- 2 Press **▲** or **▼** to select LAN.
Press **OK**.
- 3 (For Wired) Press **▲** or **▼** to select Wired LAN.
(For Wireless) Press **▲** or **▼** to select WLAN.
Press **OK**.
- 4 Press **▲** or **▼** to select TCP/IP.
Press **OK**.
- 5 Press **▲** or **▼** to select Node Name.
Press **OK**.

- 6 Enter the Node Name.
Press **OK**.

**Note**

DCP models cannot change the Node Name from the control panel menu.

- 7 Press **Stop/Exit**.

WINS Config

This selection controls how the machine obtains the IP address of the WINS server.

- 1 Press **Menu**.
- 2 Press **▲** or **▼** to select LAN.
Press **OK**.
- 3 (For Wired) Press **▲** or **▼** to select Wired LAN.
(For Wireless) Press **▲** or **▼** to select WLAN.
Press **OK**.
- 4 Press **▲** or **▼** to select TCP/IP.
Press **OK**.
- 5 Press **▲** or **▼** to select WINS Config.
Press **OK**.
- 6 Press **◀** or **▶** to select Auto or Static.
Press **OK**.
- 7 Press **Stop/Exit**.

Auto

Automatically uses a DHCP request to determine the IP addresses for the primary and secondary WINS servers. You must set the BOOT Method to Auto or DHCP for this feature to work.

Static

Uses a specified IP address for the primary and secondary WINS servers.

WINS Server

Primary WINS Server IP Address

This field specifies the IP address of the primary WINS (Windows[®] Internet Naming Service) server. If set to a non-zero value, the machine will contact this server to register its name with the Windows[®] Internet Name Service.

Secondary WINS Server IP Address

This field specifies the IP address of the secondary WINS server. It is used as a backup to the Primary WINS server address. If the Primary server is unavailable, the machine still can register itself with a secondary server. If set to a non-zero value, the machine will contact this server to register its name with the Windows® Internet Name Service. If you have a primary WINS server, but no secondary WINS server, simply leave this field blank.

- 1 Press **Menu**.
- 2 Press **▲** or **▼** to select **LAN**.
Press **OK**.
- 3 (For Wired) Press **▲** or **▼** to select **Wired LAN**.
(For Wireless) Press **▲** or **▼** to select **WLAN**.
Press **OK**.
- 4 Press **▲** or **▼** to select **TCP/IP**.
Press **OK**.
- 5 Press **▲** or **▼** to select **WINS Server**.
Press **OK**.
- 6 Press **▲** or **▼** to select **Primary** or **Secondary**.
Press **OK**.
- 7 Enter the WINS Server address.
Press **OK**.



Note

For DCP models, press **▲** or **▼** repeatedly to enter the first three-digit number for the WINS Server address. Press **▶** to enter the second three-digit number. Repeat this step until you have entered the fourth three-digit number to complete the WINS Server address. Press **OK**.

- 8 Press **Stop/Exit**.

DNS Server

Primary DNS Server IP Address

This field specifies the IP address of the primary DNS (Domain Name System) server.

Secondary DNS Server IP Address

This field specifies the IP address of the secondary DNS server. It is used as a backup to the Primary DNS server address. If the Primary server is unavailable, the machine will contact the Secondary DNS server.

- 1 Press **Menu**.
- 2 Press **▲** or **▼** to select **LAN**.
Press **OK**.

- 3 (For Wired) Press ▲ or ▼ to select `Wired LAN`.
(For Wireless) Press ▲ or ▼ to select `WLAN`.
Press **OK**.
- 4 Press ▲ or ▼ to select `TCP/IP`.
Press **OK**.
- 5 Press ▲ or ▼ to select `DNS Server`.
Press **OK**.
- 6 Press ▲ or ▼ to select `Primary` or `Secondary`.
Press **OK**.
- 7 Enter the DNS Server address.
Press **OK**.

**Note**

For DCP models, press ▲ or ▼ repeatedly to enter the first three-digit number for the DNS Server address. Press ► to enter the second three-digit number. Repeat this step until you have entered the fourth three-digit number to complete the DNS Server address. Press **OK**.

- 8 Press **Stop/Exit**.

APIPA

The setting of `On` will cause the print server to automatically allocate a Link-Local IP address in the range (169.254.1.0 - 169.254.254.255) when the print server cannot obtain an IP address through the `BOOT Method` you have set (see *BOOT Method* on page 82). Selecting `Off` means the IP address doesn't change, when the print server cannot obtain an IP address through the `BOOT Method` you have set.

- 1 Press **Menu**.
- 2 Press ▲ or ▼ to select `LAN`.
Press **OK**.
- 3 (For Wired) Press ▲ or ▼ to select `Wired LAN`.
(For Wireless) Press ▲ or ▼ to select `WLAN`.
Press **OK**.
- 4 Press ▲ or ▼ to select `TCP/IP`.
Press **OK**.
- 5 Press ▲ or ▼ to select `APIPA`.
Press **OK**.
- 6 Press ◀ or ▶ to select `On` or `Off`.
Press **OK**.
- 7 Press **Stop/Exit**.

Setup Wizard (for wireless network only)

The **Setup Wizard** guides you through the wireless network configuration. For more information, see *Using the Setup Wizard from the control panel* on page 22.

SecureEasySetup (for wireless network only)

The SecureEasySetup™ software allows you to configure the wireless network easier than configuring it manually. By pushing a button on the wireless router or access point, you can complete setup and secure the wireless network. Your router or access point must also support SecureEasySetup™. See *Using the SecureEasySetup™ or AOSS™ software to configure your machine for a wireless network* on page 24.

AOSS (for wireless network only)

The AOSS™ software allows you to configure the wireless network easier than configuring it manually. By pushing a button on the wireless router or access point, you can complete setup and secure the wireless network. Your router or access point must also support AOSS™. See *Using the SecureEasySetup™ or AOSS™ software to configure your machine for a wireless network* on page 24.

WLAN Status (for wireless network only)

Status

This field displays the current wireless network status; Active (11b), Active (11g), or Connection NG (For US), Connection Error(For UK).

- 1 Press **Menu**.
- 2 Press ▲ or ▼ to select LAN.
Press **OK**.
- 3 Press ▲ or ▼ to select WLAN.
Press **OK**.
- 4 Press ▲ or ▼ to select WLAN Status.
Press **OK**.
- 5 Press ▲ or ▼ to select Status.
Press **OK**.
- 6 The current wireless network status will be displayed; Active (11b), Active (11g), or Connection NG (For US), Connection Error(For UK)..
- 7 Press **Stop/Exit**.

Signal

This field displays the current wireless network signal strength; Strong, Medium, Weak or None.

- 1 Press **Menu**.
- 2 Press ▲ or ▼ to select LAN.
Press **OK**.
- 3 Press ▲ or ▼ to select WLAN.
Press **OK**.
- 4 Press ▲ or ▼ to select WLAN Status.
Press **OK**.
- 5 Press ▲ or ▼ to select Signal.
Press **OK**.
- 6 The current wireless network signal strength will be displayed; Strong, Medium, Weak or None.
- 7 Press **Stop/Exit**.

SSID

This field displays the current wireless network SSID. The display shows up to 32 characters of the SSID name.

- 1 Press **Menu**.
- 2 Press ▲ or ▼ to select LAN.
Press **OK**.
- 3 Press ▲ or ▼ to select WLAN.
Press **OK**.
- 4 Press ▲ or ▼ to select WLAN Status.
Press **OK**.
- 5 Press ▲ or ▼ to select SSID.
Press **OK**.
- 6 The current wireless network SSID will be displayed.
- 7 Press **Stop/Exit**.

Comm.Mode

This field displays the current wireless network communication mode; Ad-hoc or Infrastructure.

- 1 Press **Menu**.
- 2 Press ▲ or ▼ to select LAN.
Press **OK**.

- 3 Press ▲ or ▼ to select **WLAN**.
Press **OK**.
- 4 Press ▲ or ▼ to select **WLAN Status**.
Press **OK**.
- 5 Press ▲ or ▼ to select **Comm. Mode**.
Press **OK**.
- 6 The current wireless network communication mode will be displayed; **Ad-hoc** or **Infrastructure**.
- 7 Press **Stop/Exit**.

Ethernet (for wired network only)

Ethernet link mode. Auto allows the print server to operate in 100BaseTX full or half duplex, or in 10BaseT full or half duplex mode by auto negotiation.

You can fix the server link mode to 100BASE-TX Full Duplex (100B-FD) or Half Duplex (100B-HD) and 10BASE-T Full Duplex (10B-FD) or Half Duplex (10B-HD). This change is valid after the print server has been reset (default is *Auto*).



Note

If you incorrectly set this value, you may not be able to communicate with your print server.

- 1 Press **Menu**.
- 2 Press ▲ or ▼ to select **LAN**.
Press **OK**.
- 3 Press ▲ or ▼ to select **Wired LAN**.
Press **OK**.
- 4 Press ▲ or ▼ to select **Ethernet**.
Press **OK**.
- 5 Press ◀ or ▶ to select **Auto/100B-FD/100B-HD/10B-FD/10B-HD**.
Press **OK**.
- 6 Press **Stop/Exit**.

Network I/F

You can choose the network connection type, wired network connection or wireless network connection. If you want to use the wired network connection, select `Wired LAN`, and if you want to use the wireless network connection, select `WLAN`. You can only have one network connection type active at a time.

- 1 Press **Menu**.
- 2 Press **▲** or **▼** to select `LAN`.
Press **OK**.
- 3 Press **▲** or **▼** to select `Network I/F`.
Press **OK**.
- 4 Press **▲** or **▼** to select `Wired LAN` or `WLAN`.
Press **OK**.
- 5 Press **Stop/Exit**.

Printing the Network Configuration List



Note

Node Name: Node Name appears in the Network Configuration List. The default Node Name is “BRNxxxxxxxxxxxx” for a wired network or “BRWxxxxxxxxxxxx” for a wireless network (“xxxxxxxxxxxx” is your machine’s Ethernet address).

The Network Configuration List prints a report listing all the current network configuration including the network print server settings.

- 1 Press **Menu**.
- 2 Press **▲** or **▼** to select `Print Reports`.
Press **OK**.
- 3 Press **▲** or **▼** to select `Network Config`.
Press **OK**.
- 4 (For US) Press **Black Start** or **Color Start**.
(For UK) Press **Mono Start** or **Colour Start**.

Restoring the network settings to factory default

If you wish to reset the print server back to its default factory settings (resetting all information such as the password and IP address information), please follow these steps:



Note

This function restores all wired and wireless network settings to the factory default.

- 1 Press **Menu**.
- 2 Press **▲** or **▼** to select LAN.
Press **OK**.
- 3 Press **▲** or **▼** to select Factory Reset.
Press **OK**.
- 4 Press **1** for Factory Reset.
- 5 Press **1** for Reboot.



Note

For DCP model, press **+** for Factory Reset and then press **+** for Reboot.

- 6 The machine will re-start. You can now reconnect the network cable and configure the network settings to work with your network.

Overview

The Driver Deployment Wizard software can be used to ease the installation or even automate the installation of network connected printers. The Driver Deployment Wizard can also be used to create self running executable files which when run on a remote PC, completely automate the installation of a printer driver. The remote PC does not have to be connected to a network.

Connection methods

The Driver Deployment Wizard supports the two connection methods.

Peer-to-Peer

The device is connected to the network but each user prints directly to the printer WITHOUT printing through a central queue.

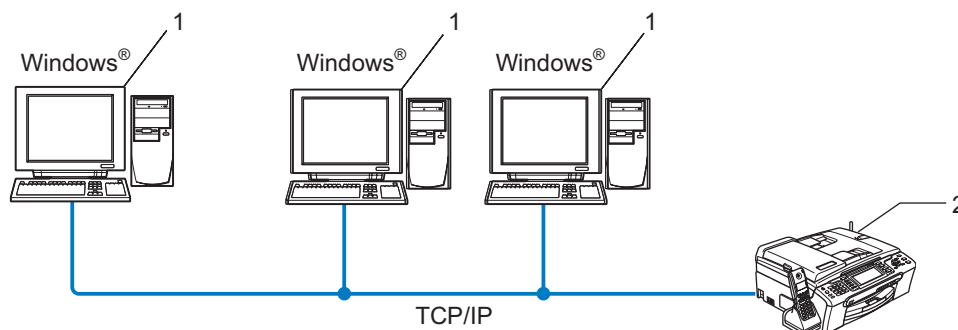

- 1 Client Computer
- 2 Network Printer (your machine)

Network Shared Printer

The device is connected to a network and a central print queue is used to manage all print jobs.

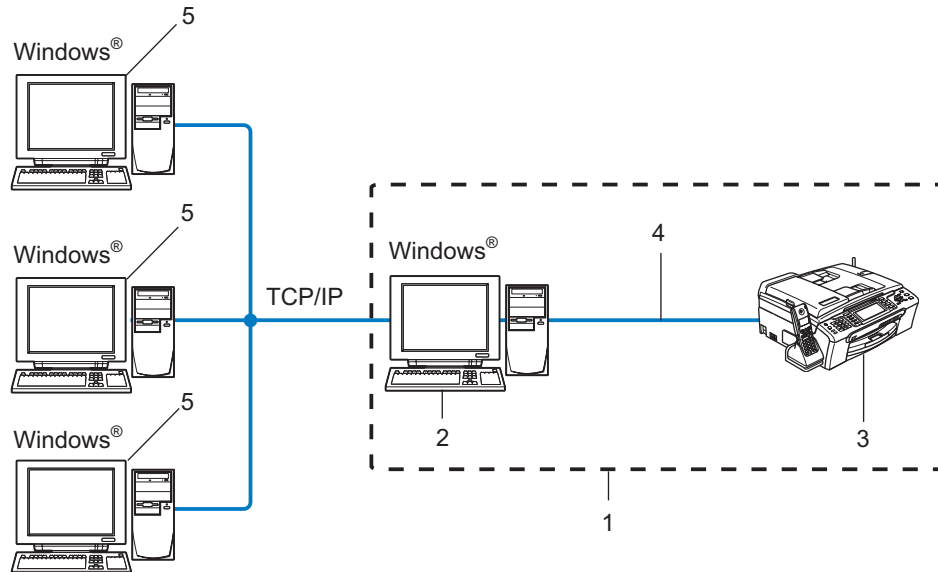

- 1 Network Shared
- 2 Print server
- 3 Printer (your machine)
- 4 TCP/IP or USB (where available)
- 5 Client Computer

How to install the Driver Deployment Wizard software

- 1 Put the supplied CD-ROM into your CD-ROM drive. If the model name screen appears, choose your machine. If the language screen appears, choose your language.
- 2 The CD-ROM main menu will appear. Click **Install Other Drivers or Utilities**.
- 3 Select the **Driver Deployment Wizard** installation program.



Note

For Windows Vista™, when the **User Account Control** screen appears, click **Continue**.

- 4 Click **Next** in response to the Welcome message.
- 5 Read the license agreement carefully. Then follow the on-screen instructions.
- 6 Click **Finish**. Now the Driver Deployment Wizard software has been installed.

Using the Driver Deployment Wizard software

- 1 When you run the Wizard for the first time you will see a welcome screen. Click **Next**.
- 2 Choose **Printer**, and then click **Next**.
- 3 Choose your connection type to the printer that you want to print to.
- 4 Choose the option you require, and follow the on-screen instructions. If you choose **Brother Peer-to-Peer Network Printer**, the following screen is displayed.

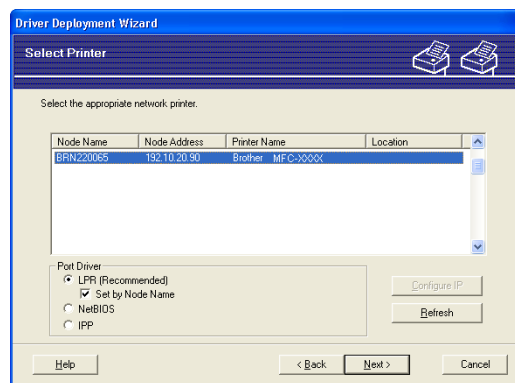

■ Setting the IP Address

If the printer does not have an IP address, the Wizard will allow you to change the IP address by selecting the printer from the list and by selecting the **Configure IP** option. A dialogue box then appears which allows you to specify information such as the IP address, subnet mask and also the gateway address.

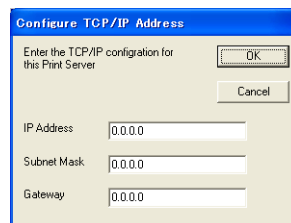

- 5 Choose the printer you wish to install, and then click **Next**. If the driver you wish to use is not installed on your computer, click **Have Disk** and then specify the path of the printer driver.

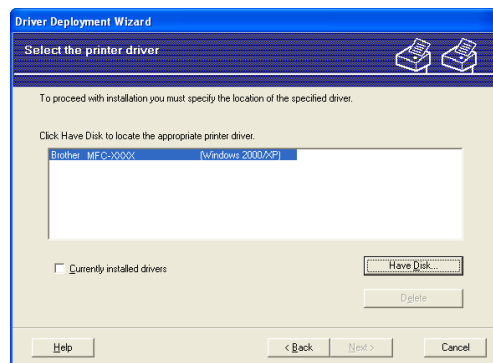

- 6 Click **Next** after you choose the correct driver.

- 7 A summary screen will appear. Confirm the settings of the driver.

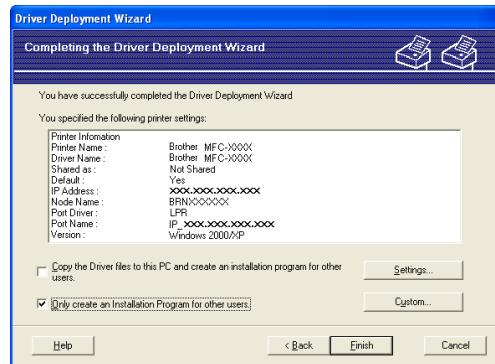

■ Creating an executable file

The Driver Deployment Wizard software can also be used to create self running .EXE files. These self-running .EXE files can be saved to the network, copied to a CD-ROM, a floppy disc or even E-mailed to another user. Once run, the driver and its settings are automatically installed without any user intervention.

- **Copy the Driver files to this PC and create an installation program for other users.**

Select this option if you wish to install the driver onto your computer and also create a self-running executable file for use with another computer using the same operating system as your own.

- **Only Create an Installation Program for other users.**

Select this option if the driver is already installed on your computer and you wish to create a self-running executable file without again installing the driver on your own computer.



Note

If you work in a "queue" based network and you create an executable file for another user who does not have access to the same printer queue that you define into the executable file, the driver when installed on the remote computer will default to LPT1 printing.

- 8 Click **Finish**. The driver is automatically installed to your computer.

Overview

If you are a Windows[®] user and want to print using the TCP/IP protocol in a Peer-to-Peer environment, please follow the instructions in this chapter. This chapter explains how to install the network software and the printer driver which you will need to be able to print using your network printer.



Note

- You must configure the IP address on your machine before you proceed with this chapter. If you have not configured the IP address, see *Setting up the IP address and subnet mask* on page 12 first.
- Verify the host computer and print server are either on the same subnet, or that the router is properly configured to pass data between the two devices.
- If you are connecting to a Network Print Queue or Share (printing only), see *Installation when using a Network Print Queue or Share (printer driver only)* on page 116 for installation details.

For Windows[®] 2000/XP and Windows Vista[™] users

By default, Windows[®] 2000/XP and Windows Vista[™] systems install the necessary print software to enable you to print. This section describes the most commonly used configuration, Standard TCP/IP Port printing.

If you have already installed the printer driver, jump to *Printer driver already installed* on page 101.

Configuring the standard TCP/IP port

Printer driver not yet installed

- 1 Put the supplied CD-ROM into your CD-ROM drive. If the model name screen appears, choose your machine. If the language screen appears, choose your language.
- 2 The CD-ROM main menu will appear. Click **Install Other Drivers or Utilities**.
- 3 Click **Printer Driver (Only, for network)**.
- 4 Click **Next** in response to the Welcome message. Follow the on-screen instructions.
- 5 Select **Standard Installation** and click **Next**.
- 6 Select **Brother Peer-to-Peer Network Printer**, and then click **Next**.
- 7 Follow the on-screen instruction, and then click **OK**.



Note

Contact your administrator if you are not sure about the location and name of the printer on the network.

- 8 Continue through the Wizard clicking **Finish** when complete.

Printer driver already installed

If you have already installed the printer driver and wish to configure it for network printing, follow these steps:

- 1 For Windows Vista™:
Click the **Start** button, **Control Panel**, **Hardware and Sound**, and then **Printers**.
For Windows® XP:
Click the **Start** button and select **Printers and Faxes** windows.
For Windows® 2000.
Click the **Start** button and select **Settings** and then **Printers**.
- 2 Right click on the printer driver you wish to configure, and then select **Properties**.
- 3 Click the **Ports** tab and click **Add Port**.
- 4 Select the port that you wish to use. Typically this would be **Standard TCP/IP Port**. Then click the **New Port...** button.
- 5 The **Standard TCP/IP Port Wizard** will start.
- 6 Enter the IP address of your network printer. Click **Next**.
- 7 Click **Finish**.
- 8 Close **Printer Ports** and **Properties** dialog box.

Other sources of information

See *Configuring your machine for a network with an Ethernet cable connection* on page 10 and *Configuring your machine for a wireless network* on page 17 to learn how to configure the IP address of the printer.

Overview

This chapter explains how to print from a Macintosh® on a Network using the Simple Network Configuration capabilities on Mac OS® X 10.2.4 or greater.

For updated information on printing from a Macintosh®, visit the Brother Solutions Center at: <http://solutions.brother.com>.

How to select the print server (TCP/IP)

- 1 Switch the machine ON.
- 2 From the **Go** menu, select **Applications**.
- 3 Open the **Utilities** folder.
- 4 Double click the **Printer Setup Utility** icon. (Mac OS® X 10.2.x users, click the **Print Center** icon.)
- 5 Click **Add**.
(For Mac OS® X 10.2.4 to 10.3.x) Go to 6.
(For Mac OS® X 10.4) Go to 7.

- 6 (For Mac OS® X 10.2.4 to 10.3.x) Make the following selection.

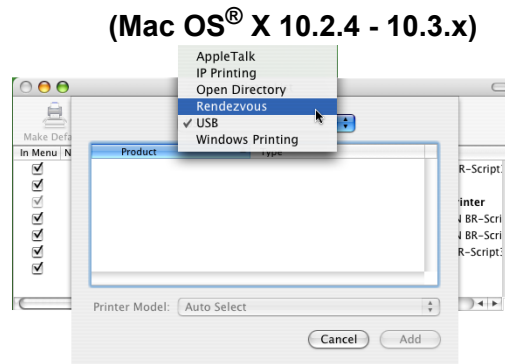

- 7 Select **Brother MFC-XXXX** (XXXX is your model name), and then click **Add**.

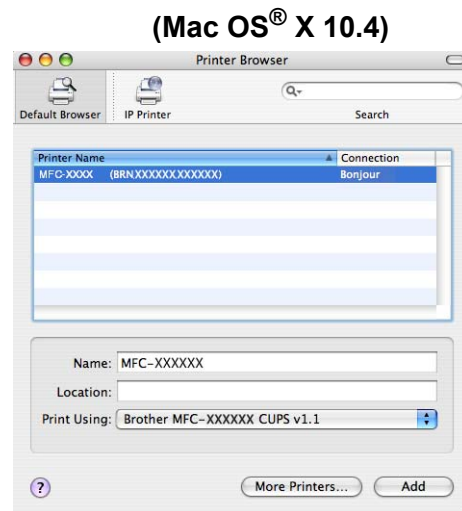

- 8 Click the printer, then click **Make Default** to set the printer as the default printer. The printer is now ready.

Changing the print server settings

Changing the configuration using the Remote Setup (Not available for DCP models)

From a Macintosh®, you can change the printer or print server parameters using the Remote Setup application. See *Using the Remote Setup to change the print server settings (Not available for DCP models)* on page 16.

Using the BRAdmin Light utility to change the print server settings

Brother BRAdmin Light utility is a Java application that is designed for Mac OS X 10.2.4 or greater environment. BRAdmin Light allows you to change network settings on Brother network ready machine



Note

- Please use the BRAdmin Light utility that was supplied on the CD-ROM of your Brother product. You can also download the latest version of the BRAdmin Light utility from <http://solutions.brother.com>.
- Node Name: Node Name appears in current BRAdmin Light. The default Node Name is BRNxxxxxxxxxxxx for a wired network or BRWxxxxxxxxxxxx for a wireless network (where xxxxxxxxxxxx is your machine's Ethernet address).

- 1 Start the BRAdmin Light utility, by double clicking the **Macintosh HD** icon on your desk top and clicking **Library / Printers / Brother / Utilities**. And then, double click the **BRAdmin Light.jar** file.
- 2 Select the print server which you want to change the settings.
- 3 Select **Configure Print Server** from the **Control** menu.
- 4 Enter a password if you have set it. You can now change the print server settings

Other sources of information

- 1 Visit <http://solutions.brother.com> for more information on network printing.
- 2 See *Setting up the IP address and subnet mask* on page 12 to learn how to configure the IP address of the printer.

Overview

This chapter explains how to resolve typical network problems you may encounter when using the machine. If, after reading this chapter, you are unable to resolve your problem, please visit the Brother Solutions Center at: <http://solutions.brother.com>

This chapter is divided into the following sections:

- General problems
- Network print software installation problems
- Printing problems
- Scanning and PC-FAX problems
- Protocol-specific troubleshooting
- Wireless network specific troubleshooting

General problems

CD-ROM is inserted, but does not start automatically

If your computer does not support Autorun, the menu will not start automatically after inserting the CD-ROM. In this case, execute **setup.exe** in the root directory of the CD-ROM.

How to reset the Brother print server to factory default

You can reset the print server back to its default factory settings (resetting all information such as the password and IP address information). See *Restoring the network settings to factory default* on page 94.

My computer cannot find the machine/print server

My machine/print server does not appear in the window of Remote Setup, BRAdmin Light or BRAdmin Professional

- For Windows®

The Firewall on your computer may be blocking the necessary network connection to the machine. In this case, you will need to disable the Firewall on your computer and re-install the drivers.

Windows® XP SP2 users:

- 1 Click the **Start** button, **Control Panel**, **Network and Internet Connections**.
- 2 Double click **Windows Firewall**.
- 3 Click the **General** tab. Make sure that **Off (not recommended)** is selected.
- 4 Click **OK**.

**Note**

After the Brother software package is installed, re-enable your Firewall.

Windows Vista™ users:

- 1 Click the **Start** button, **Control Panel**, **Network and Internet**, **Windows Firewall** and click **Change settings**.
- 2 When the **User Account Control** screen appears, do the following.
 - Users who have administrator rights: Click **Continue**.
 - For users who do not have administrator rights: Enter the administrator password and click **OK**.
- 3 Click the **General** tab. Make sure that **Off (not recommended)** is selected.
- 4 Click **OK**.

**Note**

After the Brother software package is installed, re-enable your Firewall.

- For Macintosh®

Re-select your machine in the Device Selector application located in **Macintosh HD/Library/Printers/Brother/Utilities** or from the model pull-down list of ControlCenter2.

Network print software installation problems

10

The Brother print server is not found during setup of the network print software installation or from the printer driver of the Brother machine in Windows®.

The Brother print server is not found using the Simple Network Configuration capabilities of Mac OS® X.

- For a network with an Ethernet cable connection

Make sure you have completed the IP address setting of the Brother print server according to Chapter 2 of this User's Guide before installing the network print software or printer driver.
- For a wireless network

Make sure you have completed the IP address setting and wireless network settings of the Brother print server according to Chapter 3 of this User's Guide before installing the network print software or printer driver.

Check the following:

- 1 Make sure that the machine is powered on, is on-line and ready to print.
- 2 Check to see if the LCD momentarily displays **LAN Active** after being connected to the network.

The LCD displays **LAN Active**: The print server is connected to the network.

The LCD does not display **LAN Active**: The print server is not connected to the network.

- 3 Print the Network Configuration List and check if the settings such as IP address settings are correct for your network. The problem may be the result of mismatched or duplicate IP address. Verify that the IP address is correctly loaded into the print server. And make sure that no other nodes on the network have this IP address. For information on how to print the Network Configuration List, see *Printing the Network Configuration List* on page 93.
- 4 Verify that the print server is on your network as follows:
 - **For Windows®**
 - 1 Click **Start, All Programs, Accessories** then choose **Command Prompt**.
 - 2 Try pinging the print server from the host operating system command prompt with the command:
`ping ipaddress`
Where `ipaddress` is the print server IP address (note that in some instances it can take up to two minutes for the print server to load its IP address after setting the IP address).
 - **For Mac OS® X 10.2.4 or greater**
 - 1 From the **Go** menu, select **Applications**.
 - 2 Open the **Utilities** folder.
 - 3 Double click the **Terminal** icon.
 - 4 Try pinging the print server from the Terminal window:
`ping ipaddress`
Where `ipaddress` is the print server IP address (note that in some instances it can take up to two minutes for the print server to load its IP address after setting the IP address).
- 5 If you have tried 1 to 4 above and it does not work, then reset the print server back to the default factory settings and try from the initial setup again. For information how to reset to the default factory settings, see *Restoring the network settings to factory default* on page 94.
- 6 Check the following:

If the installation failed, the Firewall on your computer may be blocking the necessary network connection to the machine. In this case, you will need to disable the Firewall on your computer and re-install the drivers. For more information, see *General problems* on page 105. If you are using a personal Firewall software, see the User's Guide for your software or contact the software manufacturer.

Printing problems

Print job is not printed

Make sure the status and configuration of the print server. Check following:

- 1 Make sure that the machine is powered on, is on-line and ready to print.
- 2 Print the Network Configuration List of the machine and check if the settings such as IP address settings are correct for your network. The problem may be the result of mismatched or duplicate IP address. Verify that the IP address is correctly loaded into the print server. And make sure that no other nodes on the network have this IP address.
- 3 Verify that the print server is on your network as follows:
 - **For Windows®**
 - 1 Try pinging the print server from the host operating system command prompt with the command:
`ping ipaddress`
Where `ipaddress` is the print server IP address (note that in some instances it can take up to two minutes for the print server to load its IP address after setting the IP address).
 - 2 If a successful response is received, then proceed to Windows® Peer-to-Peer print (LPR) troubleshooting. Otherwise, proceed to 4.
 - **For Mac OS® X 10.2.4 or greater**
 - 1 From the **Go** menu, select **Applications**.
 - 2 Open the **Utilities** folder.
 - 3 Double click the **Terminal** icon.
 - 4 Try pinging the print server from the Terminal window:

`ping ipaddress`

Where `ipaddress` is the print server IP address (note that in some instances it can take up to two minutes for the print server to load its IP address after setting the IP address).
- 4 If you have tried 1 to 3 above and it does not work, then reset the print server back to the default factory settings and try from the initial setup again. For information how to reset to the default factory settings, see *Restoring the network settings to factory default* on page 94.

Error during printing

If you try to print while other users are printing large amounts of data (e.g. many pages or color pages with high resolution), the printer is unable to accept your print job until the ongoing printing is finished. If the waiting time of your print job exceeds a certain limit, a time out situation occurs, which causes the error message. In such situations, execute the print job again after the other jobs are completed.

Scanning and PC Fax problems

The network scanning feature does not work in Windows®

The network PC Fax feature does not work in Windows®

Firewall settings on your PC may reject the necessary network connection for network printing, network scanning and PC Fax. If you are using the Windows® Firewall and you installed MFL-Pro Suite from the CD-ROM, the necessary Firewall settings have already been made. If you did not install from the CD-ROM follow the instructions below to configure your Windows Firewall. If you are using any other personal Firewall software, see the User's Guide for your software or contact the software manufacturer.

UDP Port number information for Firewall configuration

| UDP Port | Network Scanning | Network PC-Fax | Network Scanning and Network PC-Fax ¹ |
|----------------------|------------------|----------------|--|
| External Port number | 54925 | 54926 | 137 |
| Internal Port number | 54925 | 54926 | 137 |

¹ Add Port number 137 if you still have trouble with your network connection after you added port 54925 and 54926. Port number 137 also supports printing, PhotoCapture Center™ and Remote Setup over the network.

Windows® XP SP2 users:

- 1 Click the **Start** button, **Control Panel**, **Network and Internet Connection** and then **Windows Firewall**. Make sure that **Windows Firewall** on the **General** tab is set to On.
- 2 Click the **Advanced** tab and **Settings...** button.
- 3 Click the **Add** button.
- 4 Add port **54925** for network scanning by entering the information below:
 1. In **Description of service**: Enter any description, for example, "Brother Scanner".
 2. In **Name or IP address (for example 192.168.0.12)** or the computer hosting this service on your network: Enter "Localhost".
 3. In **External Port Number for this service**: Enter "54925".
 4. In **Internal Port Number for this service**: Enter "54925".
 5. Make sure **UDP** is selected.
 6. Click **OK**.
- 5 Click the **Add** button.
- 6 Add port **54926** for Network PC-Fax by entering the information below:
 1. In **Description of service**: Enter any description, for example, "Brother PC Fax".
 2. In **Name or IP address (for example 192.168.0.12)** or the computer hosting this service on your network: Enter "Localhost".
 3. In **External Port Number for this service**: Enter "54926".
 4. In **Internal Port Number for this service**: Enter "54926".
 5. Make sure **UDP** is selected.
 6. Click **OK**.

- 7 If you still have trouble with your network connection, click the **Add** button.
- 8 Add port **137** for both Network scanning and Network PC-Fax receiving by entering the information below:
 1. In **Description of service**: Enter any description, for example, "Brother PC Fax receiving"/.
 2. In **Name or IP address (for example 192.168.0.12) or the computer hosting this service on your network**: Enter "Localhost".
 3. In **External Port Number for this service**: Enter "137".
 4. In **Internal Port Number for this service**: Enter "137".
 5. Make sure **UDP** is selected.
 6. Click **OK**.
- 9 Make sure that the new setting is added and is checked, and then click **OK**.

Windows Vista™ users:

- 1 Click the **Start** button, **Control Panel**, **Network and Internet**, **Windows Firewall** and click **Change settings**.
- 2 When the **User Account Control** screen appears, do the following.
 - Users who have administrator rights: Click **Continue**.
 - For users who do not have administrator rights: Enter the administrator password and click **OK**.
- 3 Make sure that **Windows Firewall** on the **General** tab is set to On.
- 4 Click the **Exceptions** tab.
- 5 Click the **Add port...** button.
- 6 To add port **54925** for network scanning, enter the information below:
 1. In **Name**: Enter any description, for example, "Brother Scanner".
 2. In **Port number**: Enter "54925".
 3. Make sure **UDP** is selected.
 4. Click **OK**.
- 7 Click the **Add port...** button.
- 8 To add port **54926** for network PC Fax, enter the information below:
 1. In **Name**: Enter any description, for example, "Brother PC Fax".
 2. In **Port number**: - Enter "54926".
 3. Make sure **UDP** is selected.
 4. Click **OK**.
- 9 Make sure that the new setting is added and is checked, and then click **OK**.
- 10 If you still have trouble with your network connection such as network scanning or printing, check **File and Printer Sharing** box in the **Exceptions** tab and then click **OK**.

Wireless network troubleshooting

Wireless setup problems

The Brother print server is not found during setup by the Wireless Device Setup Wizard.

- 1 Make sure that the machine is powered on, is on-line and ready to print.
- 2 Move your computer closer to the Brother machine and try again.
- 3 Reset the print server back to its default factory settings and try again. For the information how to reset to the factory default settings, see *Restoring the network settings to factory default* on page 94.

Why do I have to change my machine's network setting to "Wired LAN" during setup although I am trying to setup Wireless LAN?

If you are using Windows® 2000, Mac OS® X 10.2.4 or greater or your computer is connected to the wireless network using a network cable, it is recommended you temporarily connect the machine to your access point, hub or router using a network cable. You will also need to change your machine's network setting to wired LAN temporarily. Your machine's network setting will be changed to wireless LAN during the course of the setup.

■ For Windows®:

Wireless Configuration for Windows® on page 29.

Using the Setup Wizard from the control panel on page 22.

■ For Macintosh®:

Wireless Configuration for Macintosh® on page 57.

Using the Setup Wizard from the control panel on page 22.

Wireless connection problem

The wireless network connection is sometimes disabled.

The wireless network connection status is affected by the environment where the Brother printer and other wireless devices are located. The following conditions may cause connection problems:

- A concrete or metal framed wall is located between the Brother machine and the access point.
- Electric appliances such as televisions, computer appliances, microwave ovens, intercoms, mobile/cellular phones and the battery chargers and AC power adapters are installed close to your network.
- A broadcast station or high-tension wire is located close to your network.
- A nearby fluorescent light is being switched on or off.

Using services

A service is a resource that can be accessed by computers that wish to print to the Brother print server. The Brother print server provides the following predefined services (do a `SHOW SERVICE` command in the Brother print server remote console to see a list of available services): Enter `HELP` at the command prompt for a list of supported commands.

| Service (Example) | Definition |
|-------------------|---|
| BINARY_P1 | TCP/IP binary, NetBIOS service |
| TEXT_P1 | TCP/IP text service (adds carriage return after each line feed) |
| BRNxxxxxxxxxxxx | TCP/IP binary |

Where xxxxxxxxxxxx is your machine's Ethernet address.

Other ways to set the IP address (for advanced users and administrators)

For information on how to configure your machine for a network using the BRAdmin Light utility, see *Setting up the IP address and subnet mask* on page 12.

Using DHCP to configure the IP address

The Dynamic Host Configuration Protocol (DHCP) is one of several automated mechanisms for IP address allocation. If you have a DHCP server in your network, the print server will automatically obtain its IP address from DHCP server and register its name with any RFC 1001 and 1002-compliant dynamic name services.



Note

If you do not want your print server configured via DHCP, BOOTP or RARP, you must set the `BOOT METHOD` to static so that the print server has a static IP address. This will prevent the print server from trying to obtain an IP address from any of these systems. To change the `BOOT METHOD`, use the BRAdmin Light utility.

Using BOOTP to configure the IP address

BOOTP is an alternative to `rarp` that has the advantage of allowing configuration of the subnet mask and gateway. In order to use BOOTP to configure the IP address make sure that BOOTP is installed and running on your host computer (it should appear in the `/etc/services` file on your host as a real service; type `man bootpd` or refer to your system documentation for information). BOOTP is usually started up via the `/etc/inetd.conf` file, so you may need to enable it by removing the `#` in front of the `bootp` entry in that file. For example, a typical `bootp` entry in the `/etc/inetd.conf` file would be:

```
#bootp dgram udp wait /usr/etc/bootpd bootpd -i
```

Depending on the system, this entry might be called "bootps" instead of "bootp".

 **Note**

In order to enable BOOTP, simply use an editor to delete the “#” (if there is no “#”, then BOOTP is already enabled). Then edit the BOOTP configuration file (usually `/etc/bootptab`) and enter the name, network type (1 for Ethernet), Ethernet address and the IP address, subnet mask and gateway of the print server. Unfortunately, the exact format for doing this is not standardized, so you will need to refer to your system documentation to determine how to enter this information (many UNIX[®] systems also have template examples in the `bootptab` file that you can use for reference). Some examples of typical `/etc/bootptab` entries include: (“BRN” below is “BRW” for a wireless network.)

```
BRN008077310107 1 00:80:77:31:01:07 192.189.207.3
```

and:

```
BRN008077310107:ht=ethernet:ha=008077310107:\
ip=192.189.207.3:
```

Certain BOOTP host software implementations will not respond to BOOTP requests if you have not included a download filename in the configuration file; if this is the case, simply create a null file on the host and specify the name of this file and its path in the configuration file.

As with `rarp`, the print server will load its IP address from the BOOTP server when the printer is powered on.

Using RARP to configure the IP address

The Brother print server’s IP address can be configured using the Reverse ARP (RARP) facility on your host computer. This is done by editing the `/etc/ethers` file (if this file does not exist, you can create it) with an entry similar to the following:

```
00:80:77:31:01:07 BRN008077310107 (or BRW008077310107 for a wireless network)
```

Where the first entry is the Ethernet address of the print server and the second entry is the name of the print server (the name must be the same as the one you put in the `/etc/hosts` file).

If the `rarp` daemon is not already running, start it (depending on the system the command can be `rarpd`, `rarpd -a`, `in.rarpd -a` or something else; type `man rarpd` or refer to your system documentation for additional information). To verify that the `rarp` daemon is running on a Berkeley UNIX[®] based system, type the following command:

```
ps -ax | grep -v grep | grep rarpd
```

For AT&T UNIX[®]-based systems, type:

```
ps -ef | grep -v grep | grep rarpd
```

The Brother print server will get the IP address from the `rarp` daemon when the printer is powered on.

Using APIPA to configure the IP address

The Brother print server supports the Automatic Private IP Addressing (APIPA) protocol. With APIPA, DHCP clients automatically configure an IP address and subnet mask when a DHCP server is not available. The device chooses its own IP address in the range 169.254.1.0 through to 169.254.254.255. The subnet mask is automatically set to 255.255.0.0 and the gateway address is set to 0.0.0.0.

By default, the APIPA protocol is enabled. If you want to disable the APIPA protocol, you can disable it using control panel of the machine. For more information, see *APIPA* on page 89.

If the APIPA protocol is disabled, the default IP address of a Brother print server is 192.0.0.192. However, you can easily change this IP address number to match with the IP address details of your network.

Using ARP to configure the IP address

If you are unable to use the BRAdmin application and your network does not use a DHCP server, you can also use the ARP command. The ARP command is available on Windows® systems that have TCP/IP installed as well as UNIX® systems. To use arp enter the following command at the command prompt:

```
arp -s ipaddress ethernetaddress
```

Where *ethernetaddress* is the Ethernet address (MAC address) of the print server and *ipaddress* is the IP address of the print server. For example:

■ Windows® systems

Windows® systems require the dash "-" character between each digit of the Ethernet address.

```
arp -s 192.168.1.2 00-80-77-31-01-07
```

■ UNIX®/Linux systems

Typically, UNIX® and Linux systems require the colon ":" character between each digit of the Ethernet address.

```
arp -s 192.168.1.2 00:80:77:31:01:07
```



Note

You must be on the same Ethernet segment (that is, there cannot be a router between the print server and operating system) to use the arp -s command.

If there is a router, you may use BOOTP or other methods described in this chapter to enter the IP address. If your Administrator has configured the system to deliver IP addresses using BOOTP, DHCP or RARP your Brother print server can receive an IP address from any one of these IP address allocation systems. In which case, you will not need to use the ARP command. The ARP command only works once. For security reasons, once you have successfully configured the IP address of a Brother print server using the ARP command, you cannot use the ARP command again to change the address. The print server will ignore any attempts to do this. If you wish to change the IP address again, use a web browser, TELNET (using the SET IP ADDRESS command) or factory reset the print server (which will then allow you to use the ARP command again).

To configure the print server and to verify the connection, enter the following command `ping ipaddress` where *ipaddress* is the IP address of the print server. For example, `ping 192.189.207.2`.

Using the TELNET console to configure the IP address

You can also use the TELNET command to change the IP address.

TELNET is an effective method to change the machine's IP address. But a valid IP address must already be programmed into print server.

Type `TELNET ipaddress` at the command prompt of the system prompt, where `ipaddress` is the IP address of the print server. When you are connected, push the Return or Enter key to get the “#” prompt. Enter a password if you have set it.

You will be prompted for a user name. Enter anything in response to this prompt.

You will then get the `Local>` prompt. Type `SET IP ADDRESS ipaddress`, where `ipaddress` is the desired IP address you wish to assign to the print server (check with your network administrator for the IP address to use). For example:

```
Local> SET IP ADDRESS 192.168.1.3
```

You will now need to set the subnet mask by typing `SET IP SUBNET subnet mask`, where `subnet mask` is the desired subnet mask you wish to assign to the print server (check with your network administrator for the subnet mask to use). For example:

```
Local> SET IP SUBNET 255.255.255.0
```

If you do not have any subnets, use one of the following default subnet masks:

255.0.0.0 for class A networks

255.255.0.0 for class B networks

255.255.255.0 for class C networks

The leftmost group of digits in your IP address can identify the type of network you have. The value of this group ranges from 1 through 127 for Class A networks (e.g., 13.27.7.1), 128 through 191 for Class B networks (e.g., 128.10.1.30), and 192 through 255 for Class C networks (e.g., 192.168.1.4).

If you have a gateway (router), enter its address with the command `SET IP ROUTER routeraddress`, where `routeraddress` is the desired IP address of the gateway you wish to assign to the print server. For example:

```
Local> SET IP ROUTER 192.168.1.4
```

Type `SET IP METHOD STATIC` to set the method of IP access configuration to static.

To verify that you have entered the IP information correctly, type `SHOW IP`.

Type `EXIT` or Ctrl-D (i.e., hold down the control key and type “D”) to end the remote console session.

Installation when using a Network Print Queue or Share (printer driver only)



Note

- You must configure the IP address on your machine before you proceed with this section. If you have not configured the IP address, see *Configuring your machine for a network with an Ethernet cable connection* on page 10 first.
 - Verify the host computer and print server are either on the same subnet, or that the router is properly configured to pass data between the two devices.
 - Before installation, if you are using Personal Firewall software (e.g. the Internet Connection Firewall available in Windows[®] XP), disable it. Once you are sure that you can print, re-start your Personal Firewall software.
-

- 1 Start the CD-ROM installation menu program according to the Quick Setup Guide.
- 2 Select the model name and your language (if necessary), and then click **Install Other Drivers or Utilities**.
- 3 Click **Printer Driver (Only)**.
- 4 Click **Next** in response to the Welcome message. Follow the on-screen instructions.
- 5 Select **Standard Installation** and click **Next**.
- 6 Select **Network Shared Printer**, and then click **Next**.
- 7 Select your printer's queue, and then click **OK**.



Note

Contact your administrator if you are not sure about the location and name of the printer on the network.

- 8 Click **Finish**.

Installation when using Web Services (For Windows Vista™ users)

Note

- You must configure the IP address on your machine before you proceed with this section. If you have not configured the IP address, see *Configuring your machine for a network with an Ethernet cable connection* on page 10 first.
 - Verify the host computer and print server are either on the same subnet, or that the router is properly configured to pass data between the two devices.
-

- 1 Click **Start**, then choose **Network**.
- 2 The machine's Web Services Name will be shown with the printer icon. Right click the machine you want to install.

Note

The Web Services Name for the Brother machine is your model name and the Ethernet address of your machine (e.g. Brother MFC-XXXX [XXXXXXXXXXXX]).

- 3 From the pull down menu, click **Install**.
- 4 When the **User Account Control** screen appears, do the following.
 - Users who have administrator rights: Click **Continue**.
 - For users who do not have administrator rights: Enter the administrator password and click **OK**.
- 5 Select **Locate and install driver software**.
- 6 Insert Brother CD-ROM.
- 7 Select **Don't search online** and then **Browse my computer for driver software** on your computer.
- 8 Select your CD-ROM drive then select the **driver**, and then **win2kxpvista** folder.
- 9 Select your language and then click **OK** to begin installation.

Print server specifications

Ethernet wired network

| | |
|--|--|
| Model name | NC-150h |
| Operating system support | Windows® 2000/XP/XP Professional x64 Edition, Windows Vista™ Mac OS® X 10.2.4 or greater |
| Protocol support | TCP/IP ARP, RARP, BOOTP, DHCP, APIPA (Auto IP), NetBIOS Name Resolution, WINS, DNS Resolver, LPR/LPD, Custom Raw Port/Port9100, FTP Server, mDNS, TELNET, SNMP, TFTP, Scanner Port, LLTD, Web Services |
| Network type | 10/100BASE-TX Ethernet network |
| Network printing | Windows® 2000/XP/XP Professional x64 Edition, Windows Vista™ Macintosh® printing (Mac OS® 10.2.4 or greater supporting TCP/IP) |
| Network PC-FAX | Windows® 2000/XP/XP Professional x64 Edition, Windows Vista™ Mac OS® 10.2.4 or greater (Send only) |
| Network scanning | Windows® 2000/XP/XP Professional x64 Edition, Windows Vista™ Mac OS® 10.2.4 or greater |
| Network PhotoCapture Center™ | Windows® 2000/XP/XP Professional x64 Edition, Windows Vista™ Mac OS® 10.2.4 or greater |
| Windows® Computer requirements (for drivers, BRAdmin Light, Peer-to-Peer software) | Processor Minimum Speed Pentium® II or AMD equivalent for Windows® 2000 Professional/XP AMD Opteron™, AMD Athlon™64, Intel® Xeon™ with Intel® EM64T, Intel® Pentium® 4 with Intel® EM64T for Windows® XP Professional x64 Edition, 1GHz 32-bit (x86) or 64-bit (x64) processor for Windows Vista™ |
| | Minimum RAM 64MB for Windows® 2000 Professional 128MB for Windows® XP 256MB for Windows® XP Professional x64 Edition 512MB for Windows Vista™ |
| | Recommended RAM 256MB for Windows® 2000 Professional 256MB for Windows® XP 512MB for Windows® XP Professional x64 Edition 1GB for Windows Vista™ |

| | | |
|---------------------------------|-----------------------------------|---|
| acintosh® Computer requirements | Processor Minimum Speed | PowerPC G4/G5, Intel®Core™ Solo/Duo, PowerPC G3 350MHz |
| | Minimum RAM | 128MB for Mac OS® X 10.2.4 or greater |
| | Recommended RAM | 256MB for Mac OS® X 10.2.4 or greater |
| Management utilities | BRAdmin Light | Windows® 2000/XP/XP Professional x64 Edition, Windows Vista™ Mac OS® X 10.2.4 or greater |
| | BRAdmin Professional ¹ | Windows® 2000/XP/XP Professional x64 Edition, Windows Vista™ |
| | Web BRAdmin ¹ | Windows® 2000 Professional Windows® XP Professional Windows Vista™ |

¹ Web BRAdmin and BRAdmin Professional are available as a download from <http://solutions.brother.com>.

Ethernet wireless network

| | | |
|--|---|---|
| Model name | NC-160w | |
| Operating system support | Windows [®] 2000/XP/XP Professional x64 Edition, Windows Vista [™] Mac OS [®] X 10.2.4 or greater | |
| Protocol support | TCP/IP | ARP, RARP, BOOTP, DHCP, APIPA (Auto IP), NetBIOS Name Resolution, WINS, DNS Resolver, LPR/LPD, Custom Raw Port/Port9100, FTP Server, mDNS, TELNET, SNMP, TFTP, Scanner Port, LLTD, Web Services |
| Network type | IEEE 802.11b/g wireless | |
| Frequency | 2412-2472 MHz | |
| RF channels | US/Canada | 1-11 |
| | Europe/Oceania | 1-13 |
| | Japan | 802.11b:1-14, 802.11g:1-13 |
| Communication mode | Infrastructure, Ad-hoc (802.11b only) | |
| Data rates | 802.11b | 11/5.5/2/1 Mbps |
| | 802.11g | 54/48/36/24/18/12/11/9/6/5.5/2/1 Mbps |
| Link distance | 70m (233 ft.) at lowest data rate (The distance rate will vary upon environment and other equipment location.) | |
| Network Security | SSID/ESSID, 128 (104) / 64 (40) bit WEP, WPA/WPA2-PSK(TKIP/AES) | |
| Network printing | Windows [®] 2000/XP/XP Professional x64 Edition, Windows Vista [™] TCP/IP printing Macintosh [®] printing (Mac OS [®] 10.2.4 or greater supporting TCP/IP) | |
| Network PC-FAX | Windows [®] 2000/XP/XP Professional x64 Edition, Windows Vista [™] Mac OS [®] 10.2.4 or greater (Send only) | |
| Network scanning | Windows [®] 2000/XP/XP Professional x64 Edition, Windows Vista [™] Mac OS [®] 10.2.4 or greater | |
| Network PhotoCapture Center [™] | Windows [®] 2000/XP/XP Professional x64 Edition, Windows Vista [™] Mac OS [®] 10.2.4 or greater | |

| | | |
|--|-----------------------------------|---|
| Windows® Computer requirements (for drivers, BRAdmin Light, Peer-to-Peer software, etc.) | Processor Minimum Speed | Pentium® II or AMD equivalent for Windows® 2000 Professional/XP AMD Opteron™, AMD Athlon™ 64, Intel® Xeon™ with Intel® EM64T, Intel® Pentium® 4 with Intel® EM64T for Windows® XP Professional x64 Edition, 1GHz 32-bit (x86) or 64-bit (x64) processor for Windows Vista™ |
| | Minimum RAM | 64MB for Windows® 2000 Professional 128MB for Windows® XP 256MB for Windows® XP Professional x64 Edition 512MB for Windows Vista™ |
| | Recommended RAM | 256MB for Windows® 2000 Professional 256MB for Windows® XP 512MB for Windows® XP Professional x64 Edition 1GB for Windows Vista™ |
| Macintosh® Computer requirements | Processor Minimum Speed | PowerPC G4/G5, Intel® Core™ Solo/Duo, PowerPC G3 350MHz |
| | Minimum RAM | 128MB for Mac OS® X 10.2.4 or greater |
| | Recommended RAM | 256MB for Mac OS® X 10.2.4 or greater |
| Management utilities | BRAdmin Light | Windows® 2000/XP/XP Professional x64 Edition, Windows Vista™ Mac OS® X 10.2.4 or greater |
| | BRAdmin Professional ¹ | Windows® 2000/XP/XP Professional x64 Edition, Windows Vista™ |
| | Web BRAdmin ¹ | Windows® 2000 Professional / Windows® XP Professional / Windows Vista™ |

¹ Web BRAdmin and BRAdmin Professional are available as a download from <http://solutions.brother.com>.

Function table and default factory settings

| Level1 | Level2 | Level3 | Options1 | Options2 |
|--------|-----------|--------|-------------|---|
| LAN | Wired LAN | TCP/IP | BOOT Method | Auto/Static/RARP/BOOTP/DHCP |
| | | | IP Address | [000-255].[000-255].[000-255].[000-255]. [000].[000].[000].[000] ¹ |
| | | | Subnet Mask | [000-255].[000-255].[000-255].[000-255]. [000].[000].[000].[000] ¹ |
| | | | Gateway | [000-255].[000-255].[000-255].[000-255]. [000].[000].[000].[000] |
| | | | Node Name | BRNXXXXXXXXXXXX= (your Ethernet address) (up to 15 characters) BRNXXXXXXXXXXXX* |
| | | | WINS Config | Auto/Static |
| | | | WINS Server | Primary/Secondary [000-255].[000-255].[000-255].[000-255]. [000].[000].[000].[000] |
| | | | DNS Server | Primary/Secondary [000-255].[000-255].[000-255].[000-255]. [000].[000].[000].[000] |
| | | | APIPA | On/Off |
| | | | Ethernet | Auto/100B-FD/100B-HD/10B-FD/10B-HD |

| Level1 | Level2 | Level3 | Options1 | Options2 |
|--------|--------|------------------|--|--|
| LAN | WLAN | TCP/IP | BOOT Method | Auto/Static/RARP/BOOTP/DHCP |
| | | | IP Address | [000-255].[000-255].[000-255].[000-255]. [000].[000].[000].[000] ¹ |
| | | | Subnet Mask | [000-255].[000-255].[000-255].[000-255]. [000].[000].[000].[000] ¹ |
| | | | Gateway | [000-255].[000-255].[000-255].[000-255]. [000].[000].[000].[000] |
| | | | Node Name | BRWXXXXXXXXXXXXX= (your Ethernet address) (up to 15 characters) BRWXXXXXXXXXXXXX* |
| | | | WINS Config | Auto/Static |
| | | | WINS Server | Primary/Secondary [000-255].[000-255].[000-255].[000-255]. [000].[000].[000].[000] |
| | | | DNS Server | Primary/Secondary [000-255].[000-255].[000-255].[000-255]. [000].[000].[000].[000] |
| | | | APIPA | On/Off |
| | | | Setup Wizard | Searching SSID |
| | | Secure EasySetup | Connecting WLAN/ Connected/ Connection Error | |
| | | AOSS | Setting AOSS/ Connecting AOSS/ Connection Fail | |

| Level1 | Level2 | Level3 | Options1 | Options2 |
|--------|------------------|----------------|------------------|--|
| LAN | | WLAN Status | Status | Active (11b)/Active (11g)/ Connection NG or Connection Error |
| | | | Signal | Strong/Medium/Weak/None |
| | | | SSID | (Shows SSID with up to 32 digits) |
| | | | Comm.Mode | Ad-hoc/Infrastructure |
| | Network I/F | | Wired LAN | |
| | | | WLAN | |
| | Factory Reset | | Yes/No | |

■ The factory settings are shown in bold.

¹ On connection to the network, the machine will automatically set the IP address and Subnet Mask to value appropriate for your network.

Entering Text

For MFC models

When you are setting certain menu selections, you may need to enter text into the machine. Most number keys have three or four letters printed on keys. The keys for **0**, **#** and ***** do not have printed letters because they are used for special characters.

By pressing the proper number key repeatedly, you can access the character you want.

For setting a wireless network

| Press Key | one time | two times | three times | four times | five times | six times | seven times | eight times |
|-----------|----------|-----------|-------------|------------|------------|-----------|-------------|-------------|
| 2 | a | b | c | A | B | C | 2 | a |
| 3 | d | e | f | D | E | F | 3 | b |
| 4 | g | h | i | G | H | I | 4 | g |
| 5 | j | k | l | J | K | L | 5 | j |
| 6 | m | n | o | M | N | O | 6 | m |
| 7 | p | q | r | S | P | Q | R | S |
| 8 | t | u | v | T | U | V | 8 | t |
| 9 | w | x | y | z | W | X | Y | Z |

For setting other menu selections

| Press Key | one time | two times | three times | four times |
|-----------|----------|-----------|-------------|------------|
| 2 | A | B | C | 2 |
| 3 | D | E | F | 3 |
| 4 | G | H | I | 4 |
| 5 | J | K | L | 5 |
| 6 | M | N | O | 6 |
| 7 | P | Q | R | S |
| 8 | T | U | V | 8 |
| 9 | W | X | Y | Z |

Putting spaces

To enter a space in a fax number, press ► once between numbers. To enter a space in a name, press ► twice between characters.

Making corrections

If you entered a letter incorrectly and want to change it, press ◀ to move the cursor under the incorrect character, press **Clear/Back**. Re-enter the correct character. You can also back up and insert letters.

Repeating letters

If you need to enter a letter that is on the same key as the letter before, press ► to move the cursor to the right before you press the key again.

Special characters and symbols

Press *, # or 0, and then press ◀ or ▶ to move the cursor under the special character or symbol you want. Then press **OK** to choose it. The symbols and characters below will appear depending on your menu selection.

| | |
|-------------|--|
| Press * for | (space) ! " # \$ % & ' () * + , - . / € |
| Press # for | : ; < = > ? @ [] ^ _ |
| Press 0 for | (For US) É À È Ê Î Ç Ë Ö (For UK) Ä Ë Ö Ù À Ç È É |

For DCP models

Press ▲ or ▼ repeatedly to enter the text and press **OK**.

press ◀ or ▶ repeatedly to move the cursor.

Press ▲ or ▼ for characters below

abcdefghijklmnopqrstuvwxyzABCDEFGHIJKLMNOPQRSTUVWXYZ0123456789(space)!"#\$%&'()*+,-./:;<=>@[]^`~

Making corrections

If you entered an incorrect letter and want to change it, press ◀ or ▶ to position the cursor under the incorrect letter. Use the ▲ and ▼ keys to change to the correct letter, then press ► repeatedly to move the cursor back to the end of the text.

Press **Stop**. All letters above and to the right of the cursor will be deleted. Re-enter the correct letter.

C

Index

A

| | |
|----------------|----------------|
| AES | 21 |
| AOSS™ | 24, 41, 68, 90 |
| APIPA | 8, 89, 114 |
| ARP | 114 |
| Authentication | 20 |

B

| | |
|--------------------------|-------------|
| BINARY_P1 | 112 |
| BOOTP | 8, 83, 112 |
| BRAdmin Light | 2, 12, 15 |
| BRAdmin Professional | 3, 26 |
| Brother Solutions Center | 12, 26, 104 |

C

| | |
|---------------|----|
| Channel | 20 |
| Control Panel | 82 |

D

| | |
|------------|------------|
| DHCP | 8, 84, 112 |
| DNS Client | 8 |
| DNS Server | 88 |

E

| | |
|------------|----|
| Encryption | 20 |
|------------|----|

F

| | |
|-----------------|---------------|
| Factory Default | 94 |
| Firewall | 105, 107, 109 |

G

| | |
|---------|----|
| Gateway | 86 |
|---------|----|

I

| | |
|------------|--------|
| IP Address | 10, 84 |
|------------|--------|

L

| | |
|---------|---|
| LLTD | 9 |
| LPR/LPD | 8 |

M

| | |
|---------------------|-----|
| Macintosh® Printing | 102 |
| mDNS | 8 |

N

| | |
|----------------------------|-----|
| Network Configuration List | 93 |
| Network key | 22 |
| Network Printing | 100 |
| Network Shared Printing | 5 |
| Node Name | 86 |

O

| | |
|-------------|----|
| Open system | 21 |
|-------------|----|

P

| | |
|----------------------|----------|
| Peer-to-Peer | 4 |
| Ping | 107, 108 |
| Port9100 | 8 |
| Print Server Setting | 26 |
| Print server setting | 15 |
| Protocol | 8 |

R

| | |
|--------------------------------|------------|
| RARP | 8, 83, 113 |
| Remote Setup | 16, 28 |
| Restoring the network settings | 94 |
| RFC 1001 | 112 |

S

| | |
|-------------------------------|----------------|
| SecureEasySetup™ | 24, 41, 68, 90 |
| Service | 112 |
| Shared key | 21 |
| Simple Network Configuration | 106 |
| SNMP | 8 |
| Specifications | 118 |
| SSID (Service Set Identifier) | 20 |
| Subnet Mask | 11, 85 |

T

| | |
|-----------------|--------|
| TCP/IP | 8 |
| TCP/IP Printing | 100 |
| TELNET | 8, 115 |
| Text | |
| entering | 125 |

| | |
|--------------------------|-----|
| special characters | 126 |
| TEXT_P1 | 112 |
| TKIP | 21 |
| Trademarks | i |

W

| | |
|---------------------------------|--------|
| Web BRAdmin | 3 |
| Web Services | 9, 117 |
| WEP | 21 |
| Windows Vista™ | 100 |
| Windows Vista™ Printing | 100 |
| Windows® 2000 | 100 |
| Windows® 2000/XP Printing | 100 |
| Windows® XP | 100 |
| WINS Config | 87 |
| WINS Server | 87 |
| Wireless network | 17 |
| WPA-PSK | 21 |