

Before you can use the machine, you must set up the hardware.
Please read this “Quick Setup Guide” for the correct setup procedure.

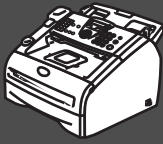

Setting Up the Machine









Setup is Complete!

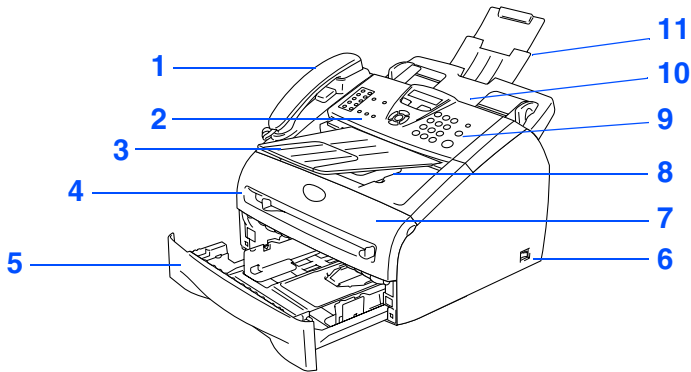
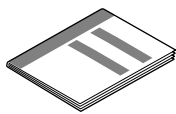
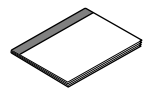

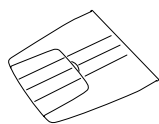
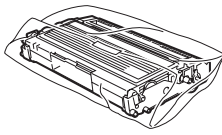

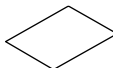
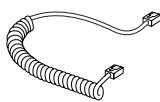
Keep this “Quick Setup Guide” and User’s Guide in a convenient place for quick and easy reference at all times.

Getting Started

Carton Components

 <ol style="list-style-type: none"> 1. Telephone Handset 2. Control Panel Cover 3. ADF Document Output Support 4. Manual Feed Slot 5. Paper Tray 6. Power Switch 7. Front Cover 8. Face-down Output Tray Support Flap with Extension 9. Control Panel (ADF) 10. Automatic Document Feeder (ADF) 11. ADF Document Support 	 <p>Quick Setup Guide</p>
	 <p>User's Guide</p>
	 <p>Telephone Handset</p>
 <p>ADF Document Output Support</p>	 <p>Drum Unit Assembly (including Starter Toner Cartridge)</p>
 <p>Test Sheet (USA only)</p>	 <p>Accessory Order Form (USA/Canada only)</p>
	 <p>Curled Handset Cord</p>
	 <p>Telephone Line Cord</p>

Carton components may differ from one country to another. Save all packing materials and the carton.

 <p>Warning</p> <p>Indicates warnings that must be observed to prevent possible personal injury.</p>	 <p>Improper Setup</p> <p>Alerts you to devices and operations that are not compatible with the machine.</p>	 <p>Note</p> <p>Indicates notes and useful tips to remember when using the machine.</p>	 <p>User's Guide</p> <p>Indicates reference to the User's Guide.</p>
--	--	---	--

Control Panel

FAX-2820, FAX-2910 and FAX-2920 have the same keys.

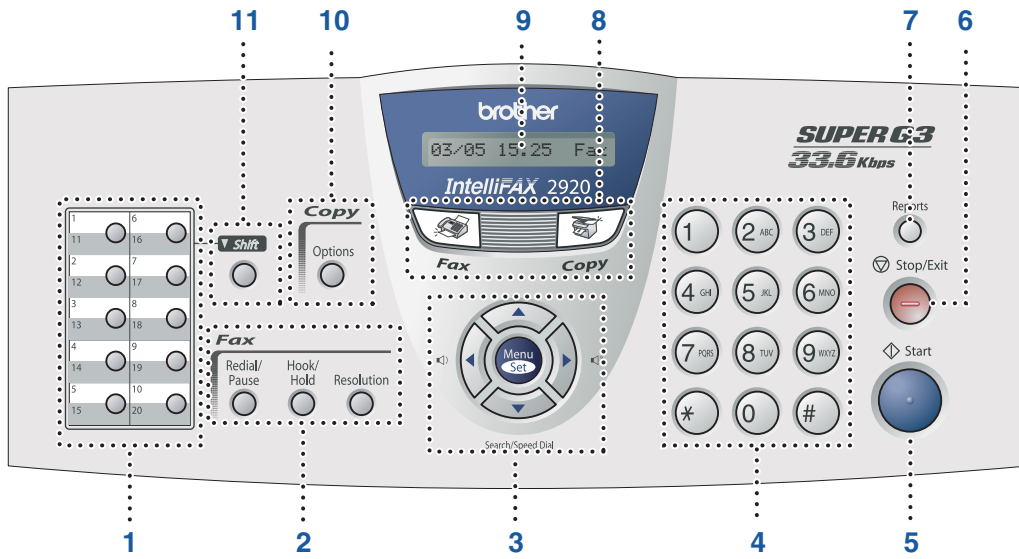

1. One Touch keys	2. Fax and telephone keys	3. Navigation keys
4. Dial Pad	5. Start key	6. Stop/Exit key
7. Reports key	8. Mode keys	9. Liquid Crystal Display(LCD)
10. Copy Options key	11. Shift key	



For the details of the control panel, see "Control panel overview" in Chapter 1 of the User's Guide.

Setting Up the Machine

1 Attach the ADF Document Output Support

- 1 Pull out the ADF Document Support.

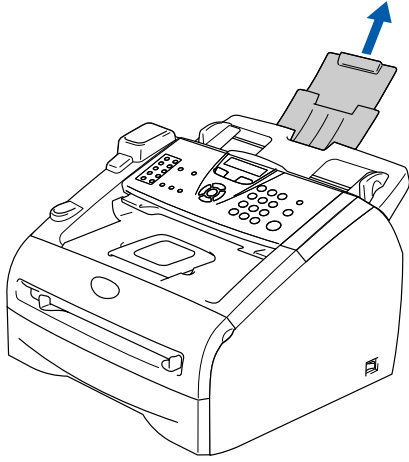

- 2 Open the control panel cover by lifting it toward the back.

Control Panel Cover

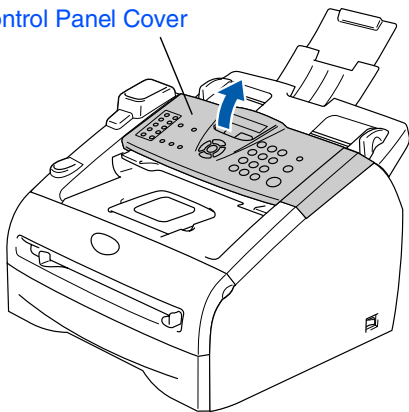

- 3 Attach the ADF Document Output Support.

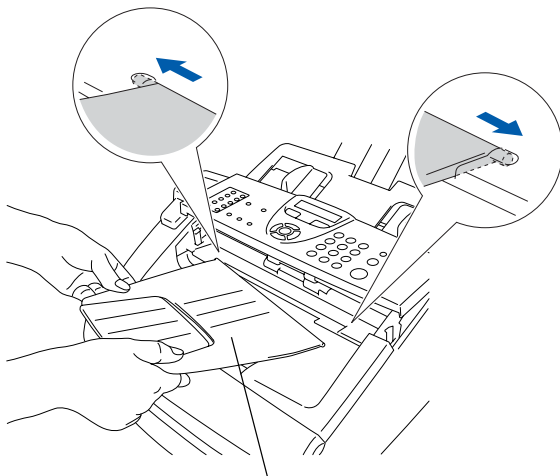

ADF Document Output Support

- 4 Close the control panel cover.

2 Install the Handset

- 1 Connect the curled handset cord to the jack on the machine marked  and the other end to the handset.

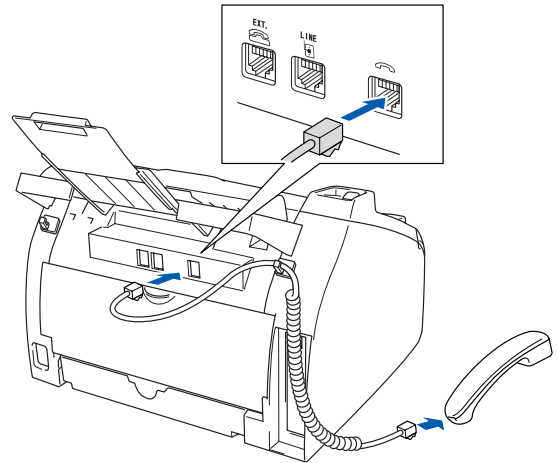

3

Install the Drum Unit Assembly

- 1 Open the front cover of the machine.

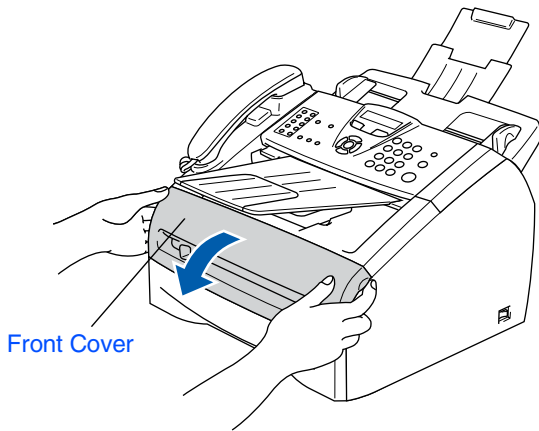

- 4 Put the drum unit assembly into the machine.

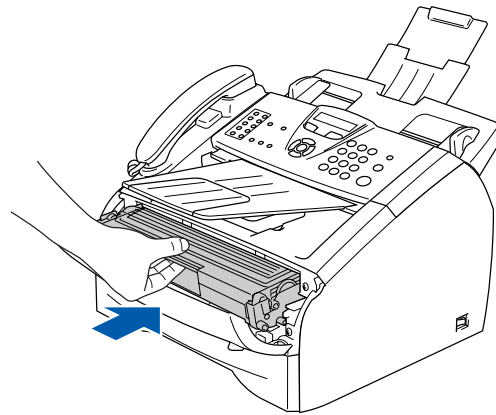

- 5 Close the front cover of the machine.

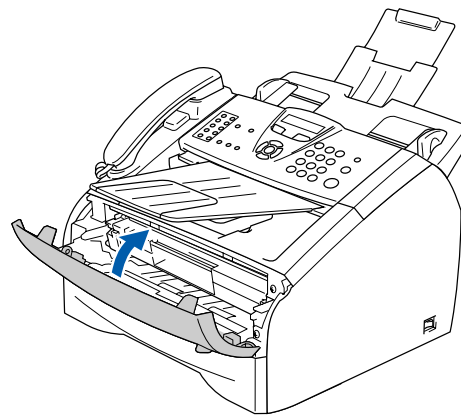

- 2 Unpack the drum unit assembly.

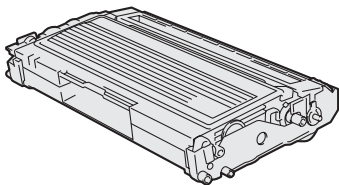

- 3 Gently rock it from side to side several times to distribute the toner evenly inside the assembly.

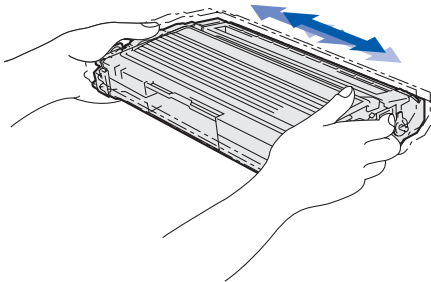

Setting Up the Machine

4 Load Paper in the Paper Tray

- 1 Pull the paper tray completely out of the machine.

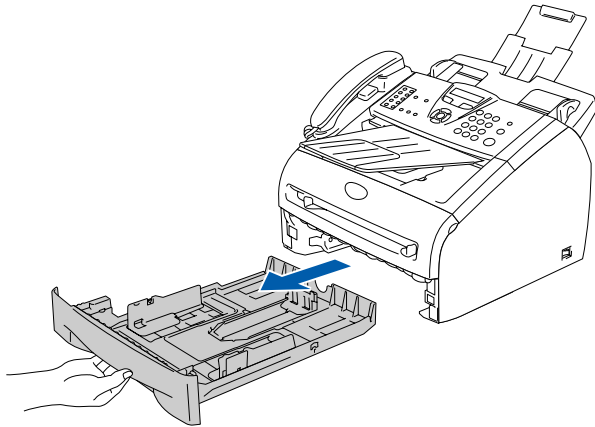

- 2 While pressing the paper guide release lever, slide the adjusters to fit the paper size. Check that the guides are firmly in the slots.

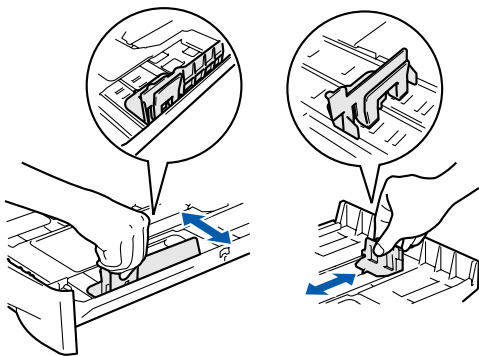

For Legal size paper, press in the inside latches and pull out the back of the paper tray.

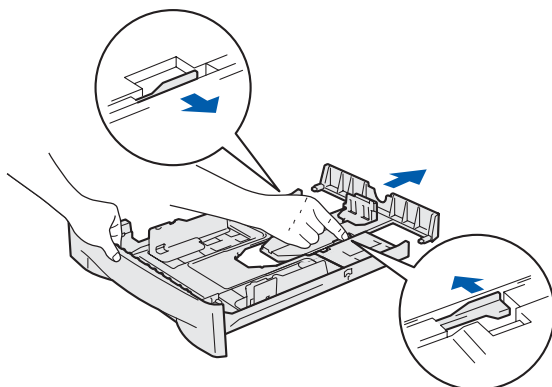

- 3 Fan the stack of paper well to avoid paper jams and misfeeds.

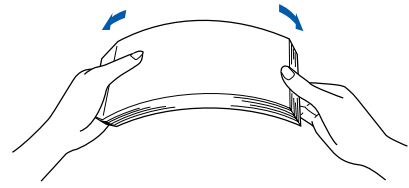

- 4 Put paper in the paper tray. Check that the paper is flat in the tray and below the maximum paper mark.

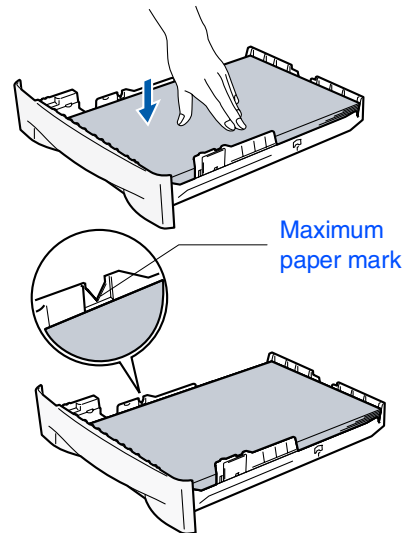

- 5 Put the paper tray firmly back into the machine and unfold the output paper tray support flap before you use the machine.

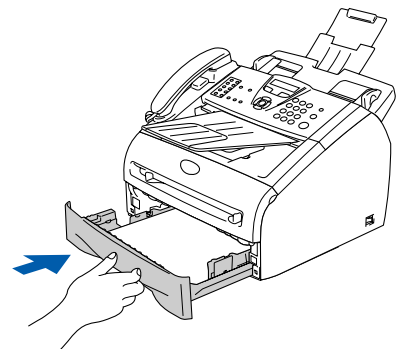

Output paper tray support flap

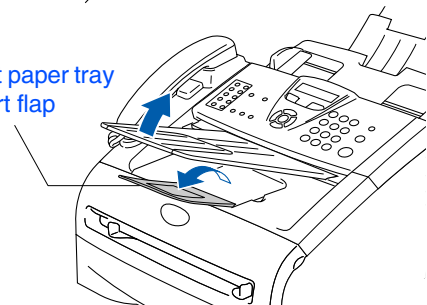

For details on supported paper specifications, see "About paper" in Chapter 1 of the User's Guide.

5

Install the Power Cord and Phone Line

- 1 Plug the AC power cord into an AC outlet. Turn the power switch on.

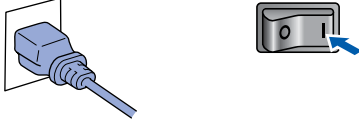

- 2 Connect one end of the telephone line cord to the jack on the machine marked **LINE** and the other end to a modular wall jack.

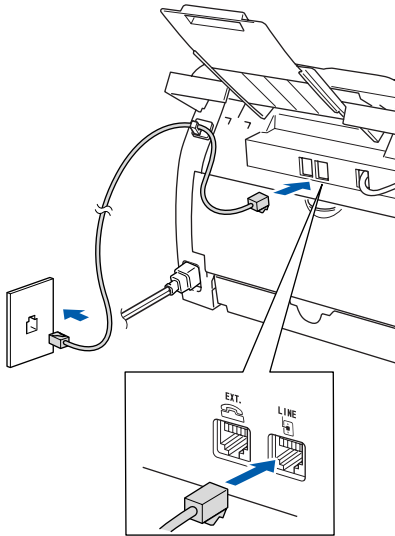

Warning

- The machine must be grounded using a 3-prong plug.
- Since the machine is grounded through the power outlet, you can protect yourself from potentially hazardous electrical conditions on the telephone network by keeping the power cord connected to your machine when you connect it to a telephone line. Similarly, you can protect yourself when you want to move your machine by disconnecting the telephone line first and then the power cord.



If you are sharing one phone line with an external telephone, connect it as shown below.

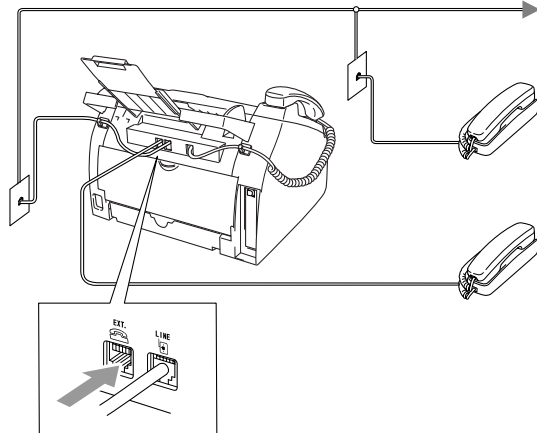

If you are sharing one phone line with an external telephone answering device, connect it as shown below.



Please set the receive mode to External TAD.

For more details, see "Connecting an external telephone answering device (TAD)" in the Appendix of the User's Guide.

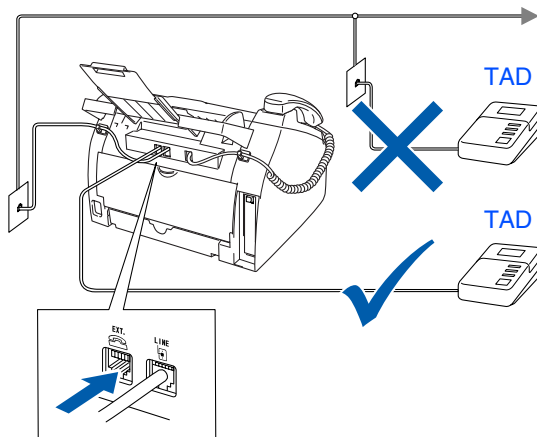

Setting Up the Machine

6 Set the Date and Time

The machine displays the date and time, and if you set up the Station ID it will add it to each fax you send.

- 1 Press **Menu/Set**.
- 2 Press **0**.
- 3 Press **2**.
- 4 Enter the last two digits of the year on the dial pad, and then press **Menu/Set**.

Year: 2007

(e.g. Enter **0, 7** for 2007.)

- 5 Enter the two digits for the month on the dial pad, and then press **Menu/Set**.

Month: 03

(e.g. Enter **0, 3** for March)

- 6 Enter the two digits for the day on the dial pad, and then press **Menu/Set**.

Day: 01

(e.g. Enter **0, 1**.)

- 7 Enter the time in 24-hour format on the dial pad, and then press **Menu/Set**.

Time: 15:25

(e.g. Enter **1, 5, 2, 5** for 3:25 P.M.)

- 8 Press **Stop/Exit**.



If you make a mistake, press **Stop/Exit** to start from Step 1.

7 Set your Station ID

You should store your name and fax number to be printed on all fax pages that you send.

- 1 Press **Menu/Set**.
- 2 Press **0**.
- 3 Press **3**.
- 4 Enter your fax number (up to 20 digits) on the dial pad, and then press **Menu/Set**.

Fax: _

- 5 Enter your telephone number (up to 20 digits) on the dial pad, and then press **Menu/Set**.
(If your telephone number and fax number are the same, enter the same number again.)

Tel: _

- 6 Use the dial pad to enter your name (up to 20 characters), and then press **Menu/Set**.

Name: _

- 7 Press **Stop/Exit**.



- Refer to the following chart for entering your name.
- If you need to enter a character that is on the same key as the previous character, press to move the cursor to the right.

Press key	One time	Two times	Three times	Four times
2	A	B	C	2
3	D	E	F	3
4	G	H	I	4
5	J	K	L	5
6	M	N	O	6
7	P	Q	R	S
8	T	U	V	8
9	W	X	Y	Z





For more details, see "Entering Text" in Appendix B of the User's Guide.

8 Select a Receive Mode

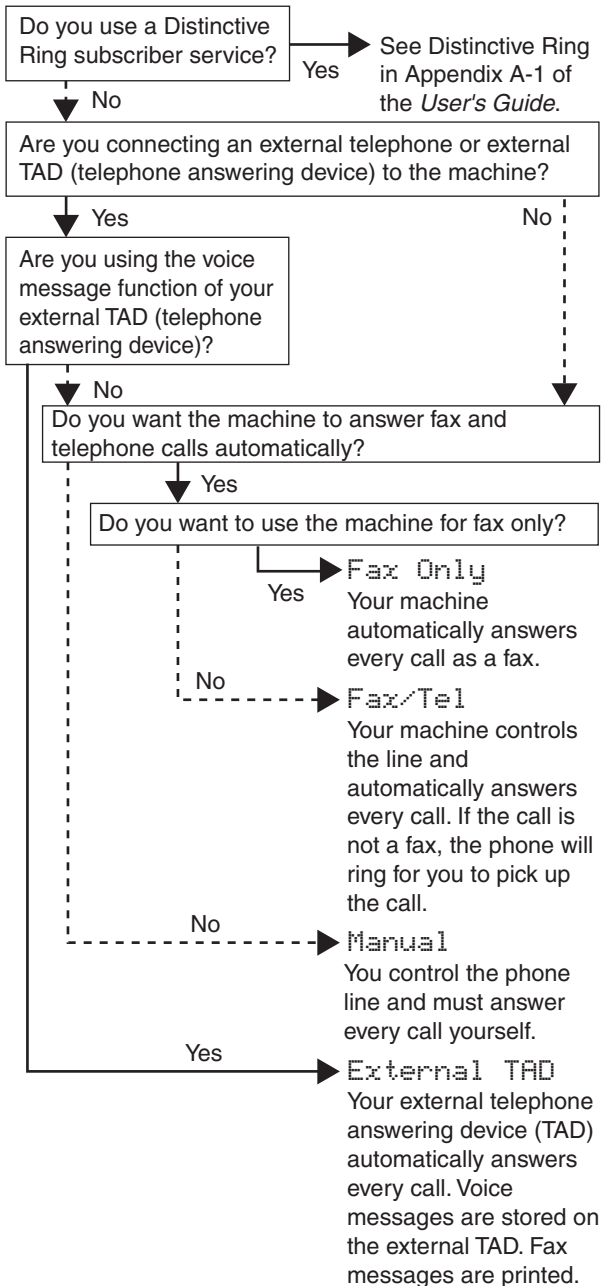
There are four possible receive modes: **Fax Only**, **Fax/Tel**, **Manual** and **External TAD**.





Choose the **Receive Mode** which best suits your needs.

- 1 Press **Menu/Set**.
- 2 Press **0**.
- 3 Press **1**.
- 4 Press  or  to select the mode. Press **Menu/Set**.
- 5 Press **Stop/Exit**.



For more details, see "Setup Receive" in Chapter 4 of the User's Guide.

9 Select Your Language (Canada only)



- 1 Press **Menu/Set**.
- 2 Press **0**.
- 3 Press **0**.
- 4 Select your language (**English** or **French**) by using  or , and then press **Menu/Set**.

Language: English

- 5 Press **Stop/Exit**.

10 Set the LCD Contrast

You can change the contrast to help the LCD look lighter or darker.

- 1 Press **Menu/Set**.
- 2 Press **1**.
- 3 Press **7**.
- 4 Press  or  to **Light** or **Dark**. Press **Menu/Set**.
- 5 Press **Stop/Exit**.

Setting Up the Machine

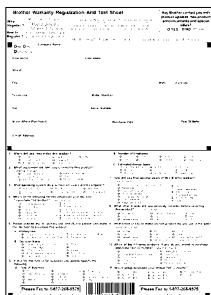

11 Send the Product Registration and Test Sheet (USA Only)

- 1 Fill out the Product Registration and Test Sheet.

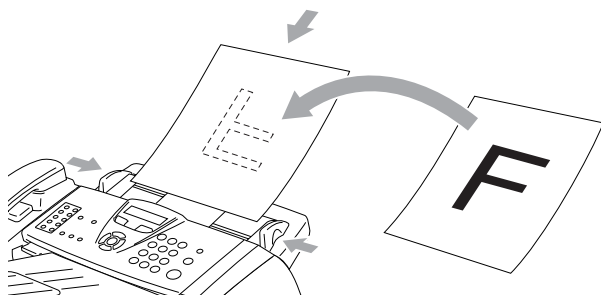

- 2 Place the sheet face down in the Automatic Document Feeder.



 Make sure  (Fax) is illuminated in Green.

- 3 Enter the toll-free fax number:
1-877-268-9575.

- 4 Press **Start**.

 You will receive a confirmation fax of your Product Registration.

 You can also register your product online going to www.brother.com/registration

12 Using the FAX as a Printer or for PC-FAX Send (FAX-2820 and FAX-2920 only)

You can download the Brother Printer Driver and PC-FAX Send driver from the Brother Solutions Center for use with FAX-2820 and FAX-2920. Visit us at:

<http://solutions.brother.com>



- Please download and install the software first before connecting the machine to your computer with the USB cable.
- You must use the appropriate USB 2.0 interface cable. If you don't have it, please purchase a USB 2.0 interface cable that is no longer than 6 feet long (2 meters).

Replacement Consumables

When the time comes to replace consumables, an error message will be indicated on the LCD. For more information about the consumables for your printer, visit <http://solutions.brother.com> or contact your local Brother re-seller.

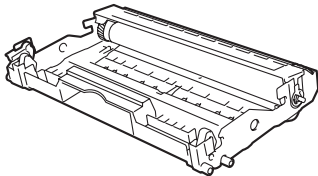
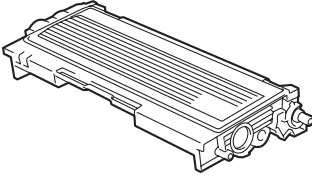
Drum Unit	Toner
DR-350	TN-350
	

Trademarks

The Brother logo is a registered trademark of Brother Industries, Ltd.
Brother is a registered trademark of Brother Industries, Ltd.

All other brand and product names mentioned in this manual are registered trademarks of their respective companies.

Compilation and Publication

Under the supervision of Brother Industries Ltd., this manual has been compiled and published, covering the latest product descriptions and specifications.

The contents of this manual and the specifications of this product are subject to change without notice.

Brother reserves the right to make changes without notice in the specifications and materials contained herein and shall not be responsible for any damages (including consequential) caused by reliance on the materials presented, including but not limited to typographical and other errors relating to the publication.

This product is designed for use in a Professional Environment.

brother®

USA/CAN