

# MFC-465CN

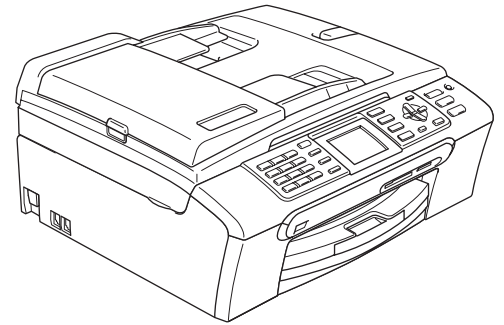

# Quick Setup Guide

Before you can use the machine, you must set up the hardware and install the software. Please read this Quick Setup Guide for the correct setup procedure and installation instructions.

## STEP 1

Setting Up the Machine







## STEP 2

Installing the Driver & Software

**Setup is Complete!**

Keep this Quick Setup Guide, the User's Guide and the supplied CD-ROM in a convenient place for quick and easy reference at all times.

## Symbols used in this guide

 Warning	 Caution	 Improper Setup
Warnings tell you what to do to prevent possible personal injury.	Cautions specify procedures you must follow or avoid to prevent possible damage to the machine or other objects.	Improper Setup icons alert you to devices and operations that are not compatible with the machine.
 Note	 User's Guide, Software User's Guide or Network User's Guide	
Notes tell you how you should respond to a situation that may arise or give tips about how the current operation works with other features.	Indicates reference to the User's Guide, Software User's Guide or Network User's Guide which is on the CD-ROM we have supplied.	

## Getting Started

---

Carton components .....	2
Control panel .....	3

## STEP 1 – Setting Up the Machine

---

Removing the protective parts .....	4
Loading paper .....	4
Connecting the power cord and telephone line .....	6
Installing the ink cartridges .....	7
Print quality check .....	9
Choosing your language (Canada only) .....	10
Setting the LCD contrast .....	11
Setting the date and time .....	11
Setting your station ID .....	12
Setting tone or pulse dialling mode .....	13
Choosing a Receive Mode .....	14
Sending in the Product Registration and Test Sheet (USA only) .....	15

## STEP 2 – Installing the Driver & Software

---

### Windows®

For USB Interface Users (For Windows® 2000 Professional/XP/ XP Professional x64 Edition/Windows Vista™) .....	18
Installing FaceFilter Studio .....	21
For Network Interface Users (For Windows® 2000 Professional/XP/ XP Professional x64 Edition/Windows Vista™) .....	22
Installing FaceFilter Studio .....	25

### Macintosh®

For USB Interface Users (For Mac OS® X 10.2.4 or greater) .....	26
For Network Interface Users (For Mac OS® X 10.2.4 or greater) .....	29

## For Network Users

---

BRAdmin Light utility (For Windows® users) .....	32
Installing the BRAdmin Light configuration utility .....	32
Setting your IP address, Subnet Mask and Gateway using BRAdmin Light .....	32
BRAdmin Light utility (For Mac OS® X users) .....	33
Setting your IP address, Subnet Mask and Gateway using BRAdmin Light .....	33

## Installing FaceFilter Studio Help

---

Instructions on how to install FaceFilter Studio Help (For Windows® users) .....	34
Installing FaceFilter Studio Help .....	34

## Consumables





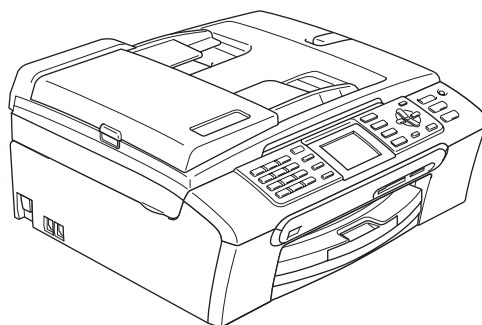

---

Replacement consumables .....	35
Ink cartridge .....	35

## Carton components

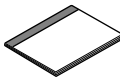
Carton components may vary from one country to another.  
Save all packing materials and the carton in case for any reason you must ship your machine.

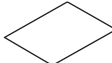
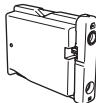
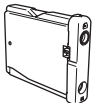

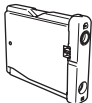
 <b>Quick Setup Guide</b>	 <b>CD-ROM</b>	 <b>User's Guide</b>	
 <b>Telephone Line Cord</b>	 <b>Test Sheet (USA only)</b>	 <b>Accessory Order Form</b>	
 <b>Black (LC51BK)</b>	 <b>Yellow (LC51Y)</b>	 <b>Cyan (LC51C)</b>	 <b>Magenta (LC51M)</b>

The ink cartridges are on top of the paper tray. See *Removing the protective parts* on page 4.

**Ink Cartridges**

An interface cable is not a standard accessory. You need to purchase an appropriate USB 2.0 interface cable or network cable.

### USB cable

- Please make sure you use a USB 2.0 cable that is no longer than 6 feet (2 meters) long.
- Your machine has a USB interface that is compatible with the USB 2.0 specification. This interface is also compatible with Hi-Speed USB 2.0; however, maximum data transfer rate will be 12 Mbits/s. The machine can also be connected to a computer that has a USB 1.1 interface.
- DO NOT connect the interface cable at this time.  
Connecting the interface cable is done during the software installation process.  
When you use a USB cable, make sure you connect it to the USB port of your computer and not to a USB port on a keyboard or a non-powered USB hub.

### Network cable

- Use a straight-through Category5 (or greater) twisted-pair cable for 10BASE-T or 100BASE-TX Fast Ethernet Network.

## Control panel



- |                          |                                |
|--------------------------|--------------------------------|
| 1 Dial Pad               | 6 On/Off key                   |
| 2 Fax and telephone keys | 7 Stop/Exit key                |
| 3 Mode keys              | 8 LCD (Liquid Crystal Display) |
| 4 Menu keys              | 9 Ink key                      |
| 5 Start keys             |                                |



For the details of the control panel, see Control panel overview in Chapter 1 of the User's Guide.

## 1 Removing the protective parts

- 1 Remove the protective tape and film covering the scanner glass.
- 2 Remove the foam bag (1) containing the ink cartridges from on top of the paper tray.

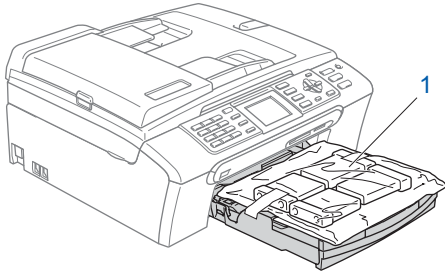

### ⊘ Improper Setup

**DO NOT** connect the interface cable.  
Connecting the interface cable is done during the software installation process.

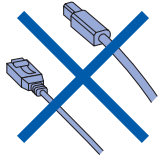

## 2 Loading paper



You can load up to 100 sheets of 20 lb (80 g/m<sup>2</sup>) paper.  
For details, see *Acceptable paper and other media* in Chapter 2 of the User's Guide.

- 1 Pull the paper tray completely out of the machine and lift the output paper tray cover (1).

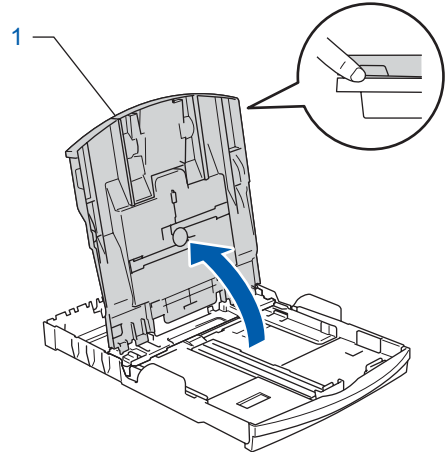
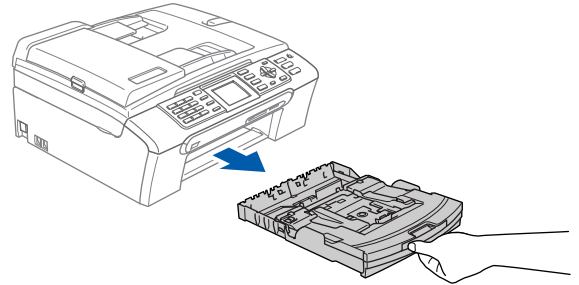

- 2 Press and slide the paper side guides (1) and paper length guide (2) to fit the paper size.

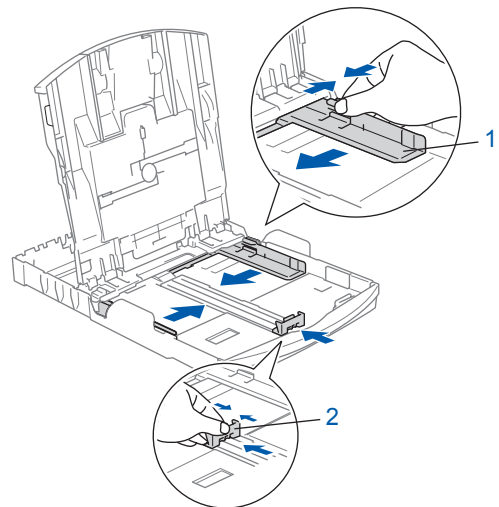

# Setting Up the Machine

- 3** Fan the stack of paper well to avoid paper jams and misfeeds.

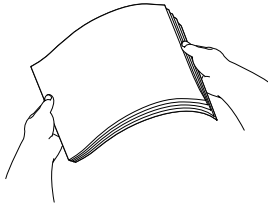

- 4** Gently put the paper into the paper tray print side down and top edge first. Check that the paper is flat in the tray.

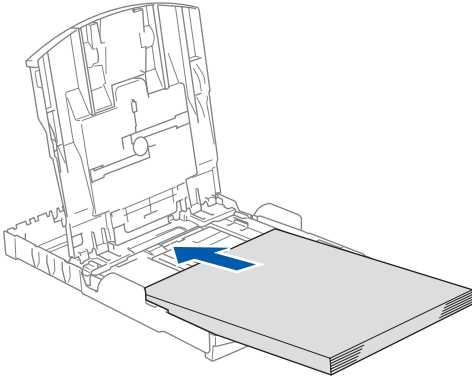

## Note

When you use Legal size paper, press and hold the universal guide release button (1) as you slide out the front of the paper tray.

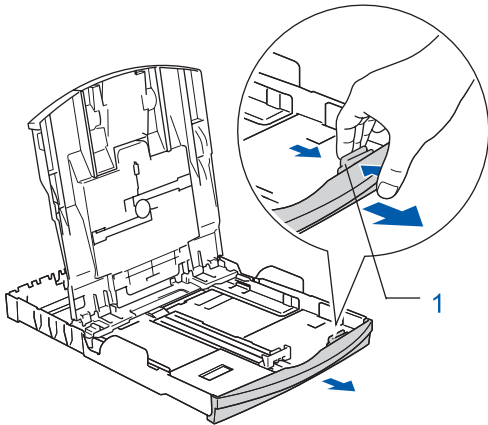

- 5** Gently adjust the paper side guides with both hands to fit the paper. Make sure that the paper side guides and paper length guide touch the edges of the paper.

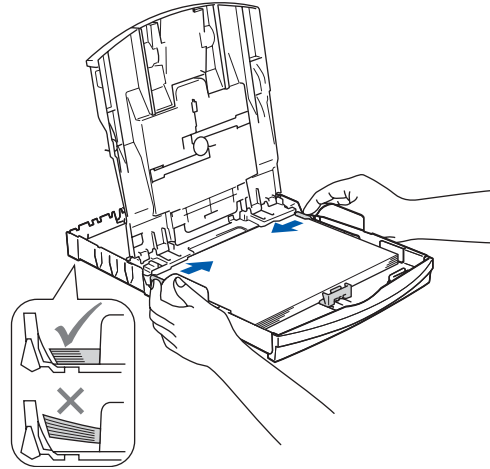

## Note

Be careful that you do not push the paper in too far; it may lift at the back of the tray and cause paper feed problems.

- 6** Close the output paper tray cover (1).

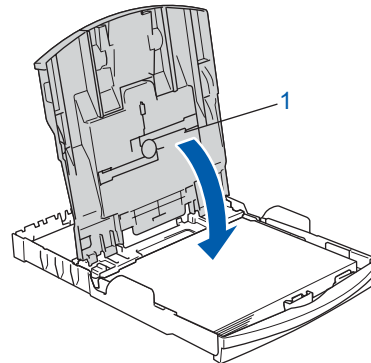

- 7** Slowly push the paper tray completely into the machine.

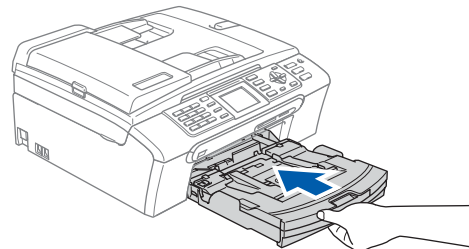

# STEP 1 Setting Up the Machine

- 8** While holding the paper tray in place, pull out the paper support ① until it clicks, and then unfold the paper support flap ②.

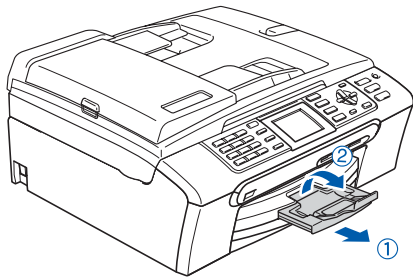

## Note

Do not use the paper support flap ② for Legal size paper.



## Note

You can use the photo bypass tray which is located on the top of the paper tray to print on photo 4 x 6 in. (10 x 15 cm) and photo L size paper. For details, see Loading photo paper in Chapter 2 of the User's Guide.

## 3 Connecting the power cord and telephone line

- 1** Connect the power cord.

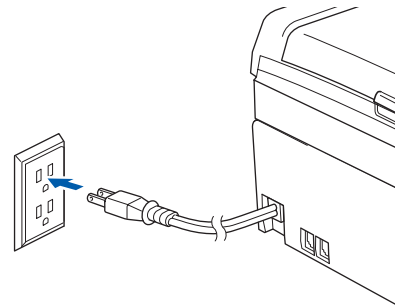

- 2** Connect the telephone line cord. Connect one end of the telephone line cord to the jack on the machine marked **LINE** and the other end to a modular wall jack.

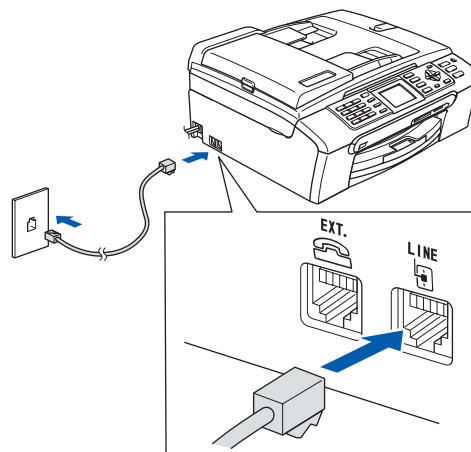

## ⊘ Improper Setup

**DO NOT** connect the interface cable. Connecting the interface cable is done during the software installation process.



## Note

If you are sharing one telephone line with an external telephone, connect it as shown below.

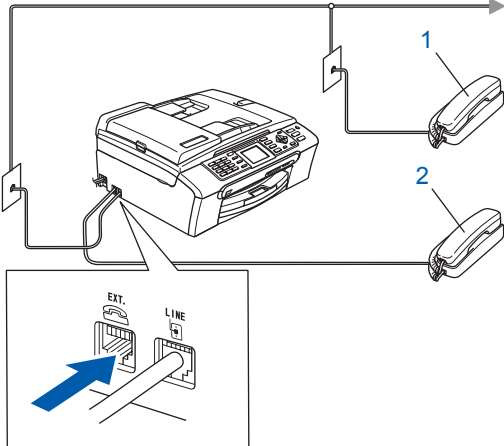

- 1 Extension telephone
- 2 External telephone

## Note

If you are sharing one telephone line with an external telephone answering machine, connect it as shown below.

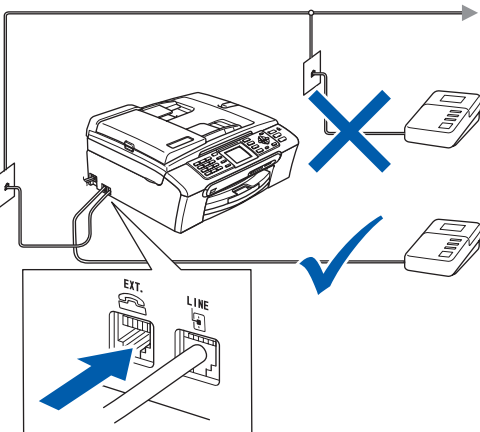

Set the receive mode to 'External TAD', if you have an external answering machine. See the section 11 Choosing a Receive Mode on page 14. For more details, see Connecting an external TAD (telephone answering device) in Chapter 7 of the User's Guide.

## 4 Installing the ink cartridges

### Warning

If ink gets in your eyes, wash them out with water at once, and if irritation occurs consult a doctor.

- 1 Make sure that the power is turned on. The LCD shows:

```
No Cartridge
Black
Yellow
Cyan
Magenta
```

- 2 Open the ink cartridge cover (1).

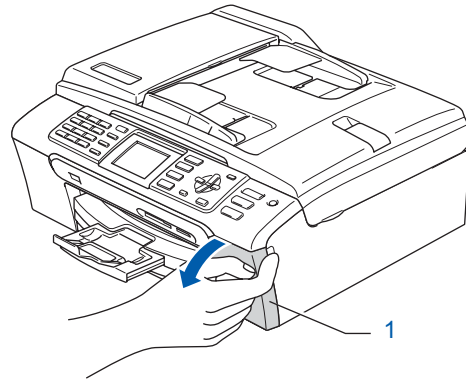

- 3 Pull all the lock release levers down and remove the yellow protective part (1).

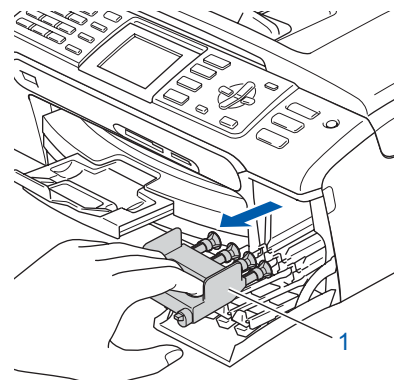
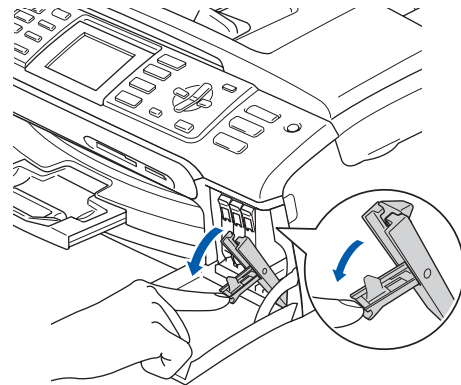

**Note**

Do not throw away the yellow protective part. You will need it if you transport the machine.

**4** Take out the ink cartridge.

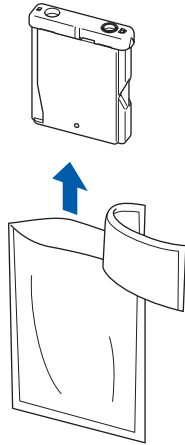

**5** Carefully remove the protective yellow cap (1).

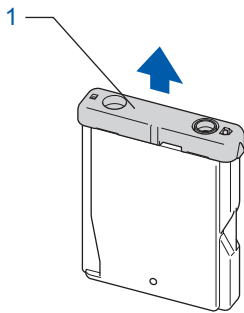

**Improper Setup**

**DO NOT** touch the area shown in the illustration below.

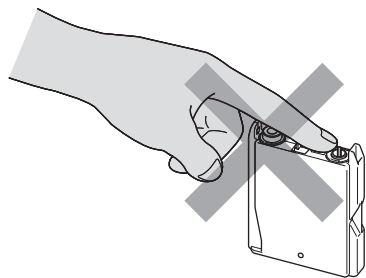

**Note**

If the protective yellow cap comes off when you open the bag, the cartridge will not be damaged.

**6** Install each ink cartridge in the direction of the arrow on the label. Take care to match the color of the lock release lever (1) with the cartridge color (2), as shown in the diagram below.

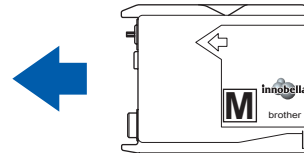
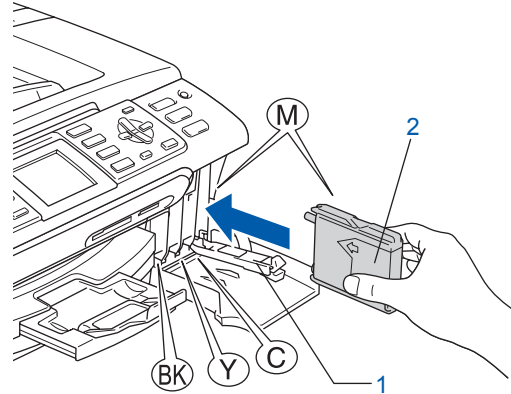

**7** Lift each lock release lever and gently push it until it clicks, and then close the ink cartridge cover.

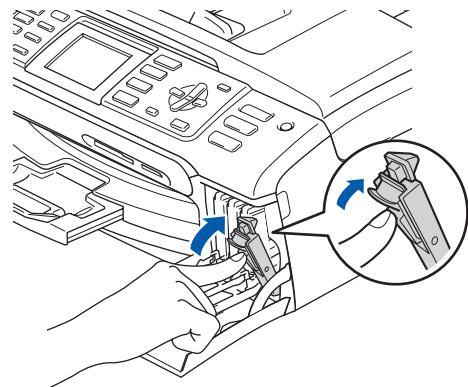

**Note**

If the LCD prompts you to re-insert the ink cartridge correctly, after you install the ink cartridges, check that the ink cartridges are installed properly.

The first time the ink cartridges are installed the machine prepares and cleans the ink tube system. This initial process will take more time than a normal cleaning cycle but will happen only once.

The LCD shows:

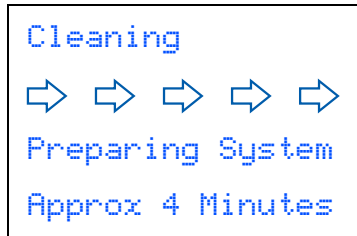

## ! Caution

- DO NOT take out ink cartridges if you do not need to replace them. If you do so, it may reduce the ink quantity and the machine will not know the quantity of ink left in the cartridge.
- DO NOT shake the ink cartridges. If ink stains your skin or clothing, wash with soap or detergent at once.
- DO NOT repeatedly insert and remove the cartridges. If you do so, ink may seep out of the cartridge.
- If you mix the colors by installing an ink cartridge in the wrong position, clean the print head several times after correcting the cartridge installation. (See Cleaning the print head in Appendix B of the User's Guide.)
- Once you open an ink cartridge, install it in the machine and use it up within six months of installation. Use unopened ink cartridges by the expiration date written on the cartridge package.
- DO NOT dismantle or tamper with the ink cartridge, this can cause the ink to leak out of the cartridge.
- Brother strongly recommends that you do not refill the ink cartridges provided with your machine. We also strongly recommend that you continue to use only Genuine Brother Brand replacement ink cartridges. Using or attempting to use potentially incompatible inks and/or cartridges in your machine may cause damage to the machine itself and/or it may result in unsatisfactory print quality. Our warranty coverage does not apply to any problem that was caused by the use of unauthorized third party ink and/or cartridges. To protect your investment and guarantee your print quality please continue to replace consumed ink cartridges with only Genuine Brother Branded Supplies.

## 5 Print quality check

- 1 After the cleaning cycle is finished, the LCD shows:

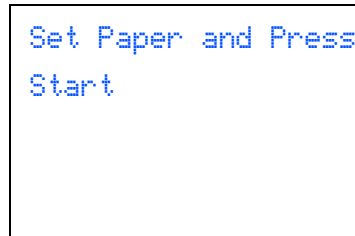

- 2 Make sure A4, Letter or Legal size paper is loaded in the paper tray.

Press **Color Start**.

The machine starts printing the Print Quality Check Sheet (only during initial ink cartridge installation).

- 3 Check the quality of the four color blocks on the sheet.  
(black/yellow/cyan/magenta)

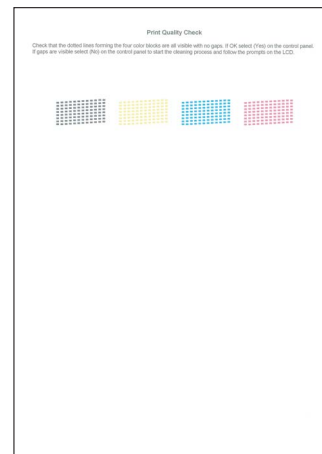

## Note

*Avoid touching the printed surface of the paper immediately after printing, the surface may not be completely dry and may stain your fingers.*

**4** The LCD shows:

```

Is Quality OK?

Yes → Press 1
No  → Press 2
  
```

- If all lines are clear and visible, press **1** (Yes) on the dial pad to finish the quality check.
- If you can see missing short lines, press **2** (No) on the dial pad and go to step **5**.

OK

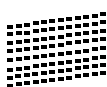

Poor

**5** The LCD asks you if the print quality is OK for black and color. Press **1** (Yes) or **2** (No) on the dial pad.

```

Black OK?

Yes → Press 1
No  → Press 2
  
```

```

Color OK?

Yes → Press 1
No  → Press 2
  
```

After pressing **1** (Yes) or **2** (No) for both black and color, the LCD shows:

```

Start Cleaning?

Yes → Press 1
No  → Press 2
  
```

**6** Press **1** (Yes), the machine will then start cleaning the colors.**7** After cleaning is finished, press **Color Start**. The machine starts printing the Print Quality Check Sheet again and goes back to step **3**.**6** Choosing your language (Canada only)

- 1** Press **Menu**.
- 2** Press **▲** or **▼** to choose **Initial Setup**. Press **OK**.
- 3** Press **▲** or **▼** to choose **Local Language**. Press **OK**.
- 4** Press **▲** or **▼** to choose your language (**English** or **French**), and then press **OK**.

```

Local Language
English
French
  
```

**5** Press **Stop/Exit**.

## 7 Setting the LCD contrast

You can adjust the LCD contrast for a sharper and more vivid display. If you are having difficulty reading the LCD, try changing the contrast setting.

- 1 Press **Menu**.
- 2 Press **▲** or **▼** to choose **General Setup**. Press **OK**.
- 3 Press **▲** or **▼** to choose **LCD Settings**. Press **OK**.
- 4 Press **▲** or **▼** to choose **LCD Contrast**. Press **OK**.
- 5 Press **▲** or **▼** to choose **Light, Med or Dark**. Press **OK**.
- 6 Press **Stop/Exit**.



### Note

You can also adjust the angle of the LCD display by lifting it.

## 8 Setting the date and time

The machine displays the time, and if you set up the station ID the date and time will be added to each fax you send.

- 1 Press **Menu**.
- 2 Press **▲** or **▼** to choose **Initial Setup**. Press **OK**.
- 3 Press **▲** or **▼** to choose **Date&Time**. Press **OK**.
- 4 Enter the last two digits of the year on the dial pad, and then press **OK**.



```
Date&Time
Year:20
07
```

(e.g. Enter **07** for 2007.)

- 5 Enter the two digits for the month on the dial pad, and then press **OK**.



```
Date&Time
Month:
03
```

(e.g. Enter **03** for March.)

- 6 Enter the two digits for the day on the dial pad, and then press **OK**.

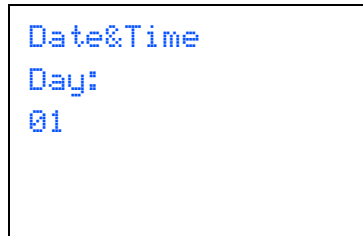

```
Date&Time
Day:
01
```

(e.g. Enter **01** for the first day of the month.)

- 7** Enter the time in 24-hour format on the dial pad, and then press **OK**.

```
Date&Time
Time:
15:25
```

(e.g. Enter **1 5, 2 5** for 3:25 P.M.)

- 8** Press **Stop/Exit**.



To confirm the current date and time, print out the User Settings report. (See Printing Reports in Chapter 10 of the User's Guide.)

## 9 Setting your station ID

You should store your name and fax number to be printed on all fax pages that you send.

- 1** Press **Menu**.
- 2** Press **▲** or **▼** to choose **Initial Setup**. Press **OK**.
- 3** Press **▲** or **▼** to choose **Station ID**. Press **OK**.
- 4** Enter your fax number (up to 20 digits) on the dial pad, and then press **OK**.

```
Station ID Fax:
-
```

- 5** Enter your name (up to 20 characters) using the dial pad, and then press **OK**.

```
Station ID Name:
-
```



### Note

- See the following chart for entering your name.
- If you need to enter a character that is on the same key as the last character, press **▶** to move the cursor to the right.
- If you entered a letter incorrectly and want to change it, press **◀** or **▶** to move the cursor to the incorrect character, press **Clear/Back**.

Press key	One time	Two times	Three times	Four times
<b>2</b>	A	B	C	2
<b>3</b>	D	E	F	3
<b>4</b>	G	H	I	4
<b>5</b>	J	K	L	5
<b>6</b>	M	N	O	6
<b>7</b>	P	Q	R	S
<b>8</b>	T	U	V	8
<b>9</b>	W	X	Y	Z

**6** Press **Stop/Exit**.

 **Note**

*If you make a mistake and want to start again, press **Stop/Exit** to go back to step 1.*



*For details, see *Entering Text* in Appendix C of the User's Guide.*

 **Note**

*(USA only)  
The Telephone Consumer Protection Act of 1991 makes it unlawful for any person to use a computer or electronic device to send any message via a telephone fax machine unless such messages clearly contain, in a margin at the top or bottom of each transmitted page, or on the first page of the transmission, the date and time it is sent and an identification of the business or other entity or other individual sending the message and the telephone number of the sending machines or such business, other entity or individual.*

## **10** Setting tone or pulse dialling mode

Your machine comes set for a Tone dialling service. If you have a Pulse dialling service (rotary), you need to change the dialling mode.

- 1** Press **Menu**.
- 2** Press **▲** or **▼** to choose `Initial Setup`. Press **OK**.
- 3** Press **▲** or **▼** to choose `Tone/Pulse`. Press **OK**.
- 4** Press **▲** or **▼** to choose `Pulse (or Tone)`. Press **OK**.
- 5** Press **Stop/Exit**.

## 11 Choosing a Receive Mode

There are four possible receive modes: Fax Only, Fax/Tel, Manual and External TAD.

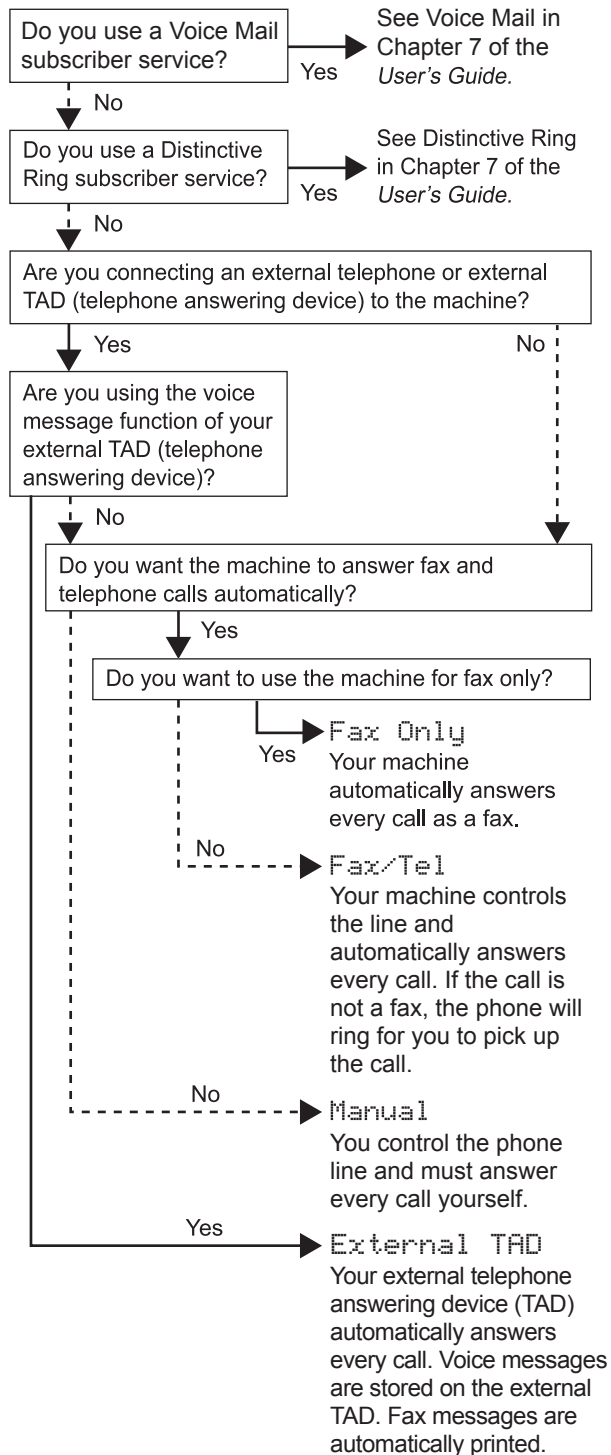

- 1 Press **Menu**.
- 2 Press **▲** or **▼** to choose **Initial Setup**. Press **OK**.
- 3 Press **▲** or **▼** to choose **Receive Mode**. Press **OK**.
- 4 Press **▲** or **▼** to choose the mode. Press **OK**.
- 5 Press **Stop/Exit**.



For details, see *Using receive modes in Chapter 6 of the User's Guide*.



## 12 Sending in the Product Registration and Test Sheet (USA only)

**1** Fill out the Product Registration and Test Sheet.

### Note

You will receive a confirmation fax of your Product Registration.  
 You can also register your product online using the On-Line Registration link from the installation CD-ROM or visit <http://www.brother.com/registration>.

### Now go to

Supplied CD-ROM 'MFL-Pro Suite' on the next page to install the drivers.

**2** Put the sheet face down in the ADF (Automatic Document Feeder) or the scanner glass.

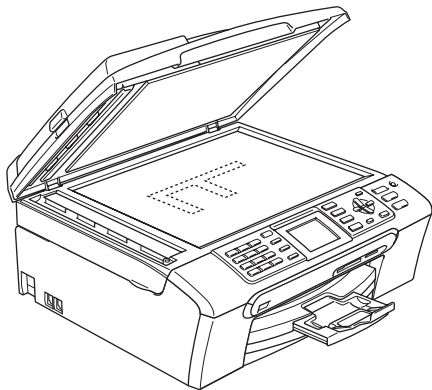
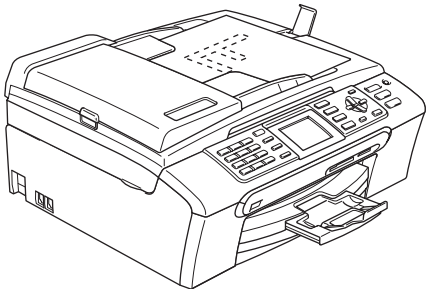

**3** Make sure  (Fax) is illuminated in Green.

**4** Enter the toll-free fax number: 1-877-268-9575.

**5** Press **Black Start**.

## Supplied CD-ROM 'MFL-Pro Suite'

### Windows®

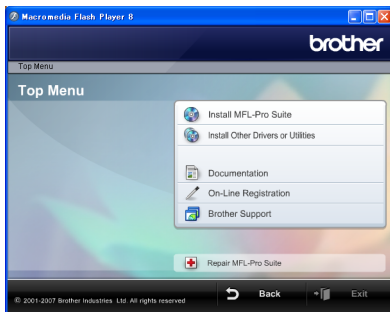

#### **Install MFL-Pro Suite**

You can install the MFL-Pro Suite software and multifunction drivers.

#### **Install Other Drivers or Utilities**

You can install additional MFL-Pro Suite software utilities, install without ScanSoft™ PaperPort™ 11SE with OCR by NUANCE™, install the printer driver only or install FaceFilter Studio.

#### **Documentation**

View the Software User's Guide and Network User's Guide in HTML format. You can also view the manuals in PDF format by accessing the Brother Solutions Center. The Software User's Guide and Network User's Guide include instructions for features available when connected to a computer. (eg. Printing, scanning and networking details)

#### **On-Line Registration**

Register your machine from the Brother Product Registration Page.

#### **Brother Support**

View contact information for Brother Customer Service and how to find a Brother Authorized Service Center. View our web site for original/genuine Brother supplies at <http://www.brother.com/original/> for Supplies Information.

#### **Repair MFL-Pro Suite (USB only)**

If an error occurred during the installation of the MFL-Pro Suite, use this selection to automatically repair and re-install the MFL-Pro Suite.

#### **Note**

*MFL-Pro Suite includes the Printer Driver, Scanner Driver, Brother ControlCenter3, ScanSoft™ PaperPort™ 11SE. ScanSoft™ PaperPort™ 11SE is a document management application for scanning and viewing documents.*

### Macintosh®



#### **Start Here OSX**

You can install the MFL-Pro Suite that includes the printer driver, scanner driver, Brother ControlCenter2 and BRAdmin Light for Mac OS® X 10.2.4 or greater.

#### **Presto! PageManager**

You can also install Presto!® PageManager® to add OCR capability to Brother ControlCenter2 and easily scan, share and organize photos and documents.

For Mac OS® X 10.3.9 or greater users, you can directly install the software from the included CD-ROM, follow the steps in Installing the Drivers & Software.

For Mac OS® X 10.2.4 to 10.3.8 users, you need to download the software from the Brother Solutions Center web site. To download, follow the steps in Installing the Drivers & Software.

#### **Documentation**

View the Software User's Guide and Network User's Guide in HTML format. You can also view the manuals in PDF format by accessing the Brother Solutions Center. The Software User's Guide and Network User's Guide include instructions for features available when connected to a computer. (eg. Printing, scanning and networking details)

#### **Brother Solutions Center**

Access the Brother Solutions Center for FAQs, User's Guides, driver updates and tips for using your machine. (Internet access required)

#### **On-Line Registration**

Register your machine from the Brother Product Registration Page.

#### **Utilities**

You can find the following additional Utilities from this folder.

- Presto!® PageManager® Uninstaller
- BRAdmin Light

# STEP 2

# Installing the Driver & Software

Follow the instructions on this page for your operating system and interface.  
For the latest drivers, documentation, and to find the best solution for your problem, access the Brother Solution Center directly from the CD-ROM / Driver or visit <http://solutions.brother.com>.

## Windows®



**For USB Interface Users**  
(For Windows® 2000 Professional/XP/  
XP Professional x64 Edition/Windows Vista™) ..... 18



**For Network Interface Users**  
(For Windows® 2000 Professional/XP/  
XP Professional x64 Edition/Windows Vista™) ..... 22

## Macintosh®



**For USB Interface Users**  
(For Mac OS® X 10.2.4 or greater) ..... 26



**For Network Interface Users**  
(For Mac OS® X 10.2.4 or greater) ..... 29

The screens for Windows® in this Quick Setup Guide are based on Windows® XP.  
The screens for Mac OS® X in this Quick Setup Guide are based on Mac OS® X 10.4.

Screens on your computer may vary depending on your operating system.

## For USB Interface Users (For Windows® 2000 Professional/XP/ XP Professional x64 Edition/Windows Vista™)

### Important

Make sure that you have finished the instructions from **STEP 1 Setting Up the Machine** on pages 4 through 14.

### Note

- The supplied CD-ROM includes ScanSoft™ PaperPort™ 11SE. This software supports Windows® 2000 (SP4 or greater), XP (SP2 or greater), XP Professional x64 Edition and Windows Vista™ only. Please update to the latest Windows® Service Pack before installing MFL-Pro Suite.
- Please close any applications running before installing MFL-Pro Suite.
- Make sure there are no memory cards or a USB Flash memory drive inserted into the media drives or USB direct interface at the front of the machine.

- 1 Unplug the machine from the AC outlet and from your computer, if you already connected an interface cable.

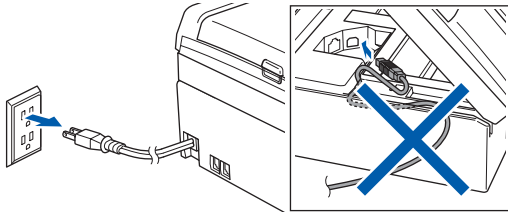

- 2 Turn on your computer. You must be logged on with Administrator rights.

- 3 Put the supplied CD-ROM into your CD-ROM drive. If the model name screen appears, choose your machine. If the language screen appears, choose your language.

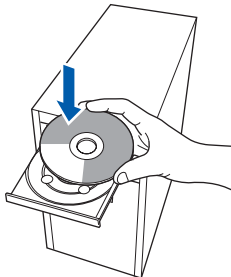

- 4 The CD-ROM main menu will appear. Click **Install MFL-Pro Suite**.



If this window does not appear, use Windows® Explorer to run the **start.exe** program from the root folder of the Brother CD-ROM.

### Note

- If this screen appears, click **OK** and restart your computer.
- If the installation does not continue automatically, open the main menu again by ejecting and then reinserting the CD-ROM disc or double-click the **start.exe** program from the root folder, and continue from Step 4 to install MFL-Pro Suite.
- For Windows Vista™, when the User Account Control screen appears, click **Allow**.

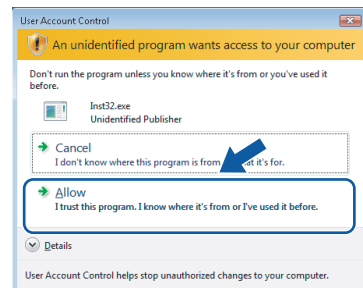
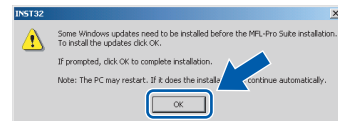

- 5** After reading and accepting the ScanSoft™ PaperPort™ 11SE License Agreement, click **Yes**.

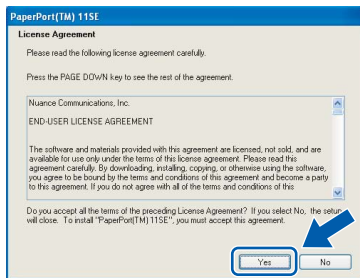

- 6** The installation of ScanSoft™ PaperPort™ 11SE will automatically start and is followed by the installation of MFL-Pro Suite.

- 7** When the Brother MFL-Pro Suite Software License Agreement window appears, click **Yes** if you agree to the Software License Agreement.

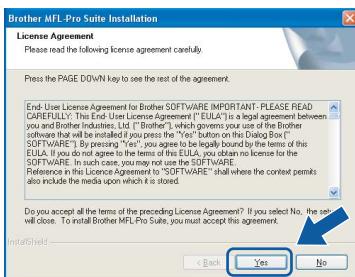

- 8** Choose **Local Connection**, and then click **Next**. The installation continues.

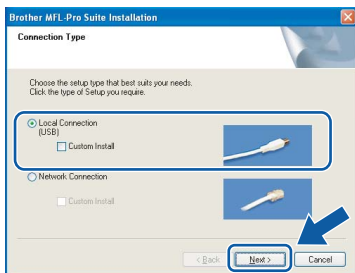

**Note**

For Windows Vista™, when this screen appears, click the check box and click **Install** to complete the installation properly.

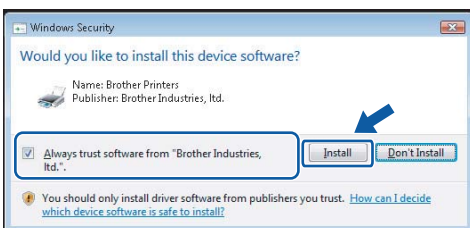

- 9** When this screen appears, go to the next step.

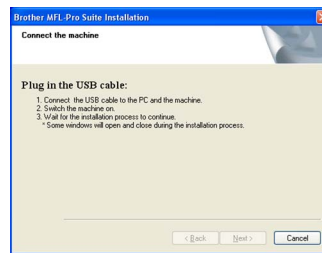

- 10** Using both hands, use the plastic tabs on both sides of the machine to lift the scanner cover until it locks securely into the open position.

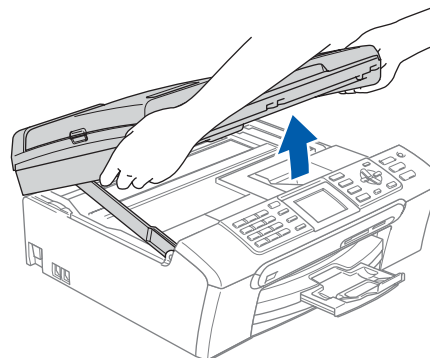

- 11** Insert the USB cable into the USB socket marked with a  symbol. You will find the USB socket inside the machine on the right as shown below.

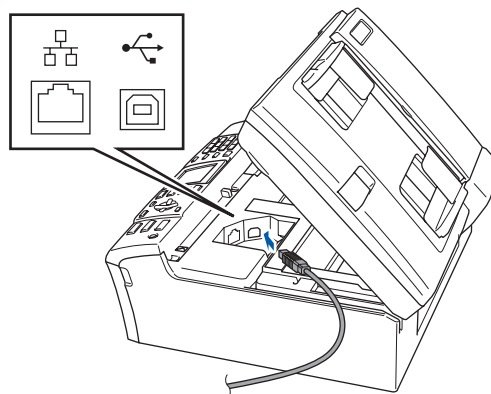

**12** Carefully route the USB cable through the trench and out the back of the machine as shown below and connect the cable to your computer.

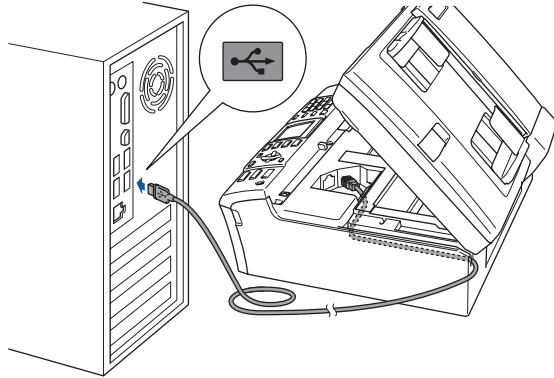

**14** Turn on the machine by connecting the power cord.

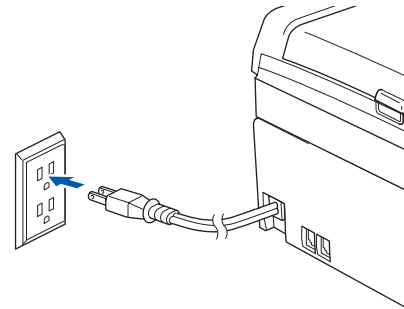

The installation of the Brother drivers will automatically start. The installation screens appear one after another. **Please wait, it will take a few seconds for all the screens to appear.**

### ⊘ Improper Setup

- **DO NOT** connect the machine to a USB port on a keyboard or a non-powered USB hub. Brother recommends that you connect the machine directly to your computer.
- **Make sure that the cable does not restrict the cover from closing, or an error may occur.**
- **Make sure you use a USB 2.0 cable that is no longer than 6 feet (2 meters) long.**

### ⊘ Improper Setup

**DO NOT** try to cancel any of the screens during this installation.

**13** Lift the scanner cover to release the lock ①. Gently push the scanner cover support down ② and close the scanner cover ③.

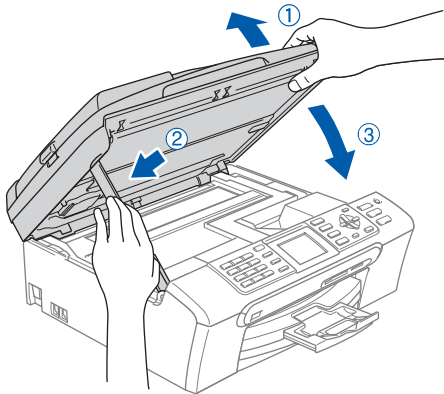

**15** When the On-Line Registration screen is displayed, make your selection and follow the on-screen instructions.

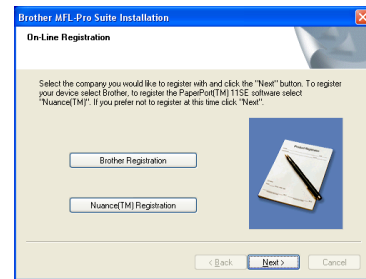

**16** Click **Finish** to restart your computer. After restarting the computer, you must be logged on with Administrator rights.



### Note

*After restarting the computer, the Installation Diagnostics will run automatically. If the installation is unsuccessful, the installation results window will be shown. If the Diagnostics shows a failure, please follow the on-screen instructions or read the on-line help and FAQ's in **Start/All Programs/Brother/MFC-XXXX**.*



The MFL-Pro Suite has been installed completely. Proceed to *Installing FaceFilter Studio* on page 21 to install the FaceFilter Studio application.



**Note**

MFL-Pro Suite includes the Printer Driver, Scanner Driver, Brother ControlCenter3, ScanSoft™ PaperPort™ 11SE. ScanSoft™ PaperPort™ 11SE is a document management application for scanning and viewing documents.

## Installing FaceFilter Studio

FaceFilter Studio is an easy-to-use borderless photo printing application. FaceFilter Studio also lets you edit your photo data and add photo effects such as red eye reduction or skin tone enhancement.

Windows®  
USB

### Important

**Before you launch FaceFilter Studio for the first time, you must confirm MFL-Pro Suite is installed, your Brother machine is turned ON and connected to your computer.**

- 17** Open the main menu again by ejecting and then reinserting the CD-ROM disc or by double-clicking the **start.exe** program from the root folder.
- 18** The CD-ROM main menu will appear. Click **Install Other Drivers or Utilities**.

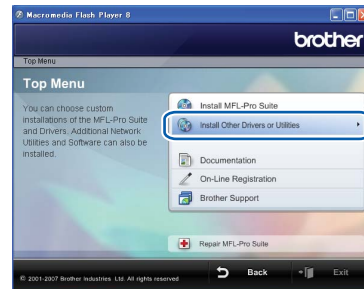

- 19** Click the **FaceFilter Studio** button to install.

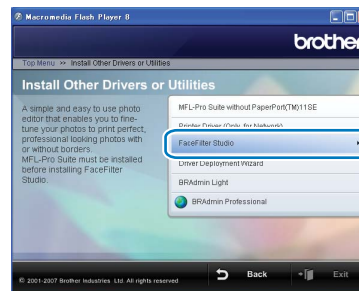

- 20** For information on basic FaceFilter Studio functions, see *Using FaceFilter Studio for photo printing by REALLUSION* in the Software User's Guide on the CD-ROM. For more detailed information, install FaceFilter Studio Help. See *Instructions on how to install FaceFilter Studio Help (For Windows® users)* on page 34.

## For Network Interface Users (For Windows® 2000 Professional/XP/ XP Professional x64 Edition/Windows Vista™)

### Important

Make sure that you have finished the instructions from **STEP 1 Setting Up the Machine** on pages 4 through 14.

### Note

- The supplied CD-ROM includes ScanSoft™ PaperPort™ 11SE. This software supports Windows® 2000 (SP4 or greater), XP (SP2 or greater), XP Professional x64 Edition and Windows Vista™ only. Please update to the latest Windows® Service Pack before installing MFL-Pro Suite.
- Please close any applications running before installing MFL-Pro Suite.
- Make sure there are no memory cards or a USB Flash memory drive inserted into the media drives or USB direct interface at the front of the machine.

**1** Unplug the machine from the AC outlet.

**2** Using both hands, use the plastic tabs on both sides of the machine to lift the scanner cover until it locks securely into the open position.

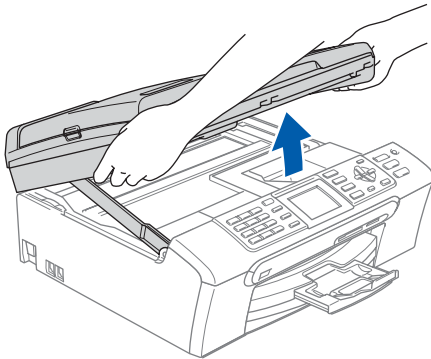

**3** Insert the network cable into the LAN socket marked with a  symbol. You will find the LAN socket inside the machine on the left as shown below.

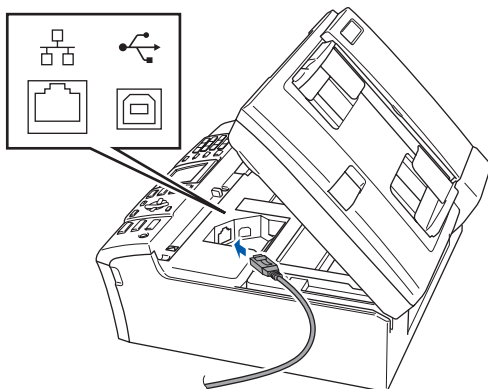

**4** Carefully route the network cable through the trench and out the back of the machine. Then, connect the cable to your network.

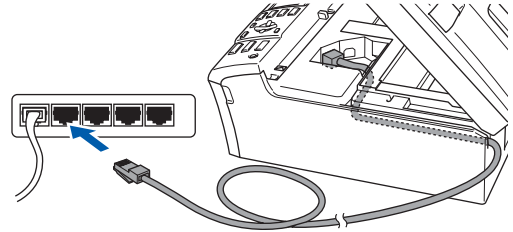

### Improper Setup

Make sure that the cable does not restrict the cover from closing, or an error may occur.

### Note

If both USB and LAN cables are being used, guide both cables through the trench with one on top of the other.

**5** Lift the scanner cover to release the lock **①**. Gently push the scanner cover support down **②** and close the scanner cover **③**.

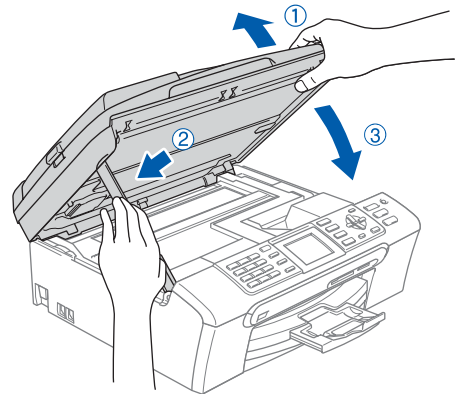

**6** Turn on the machine by connecting the power cord.

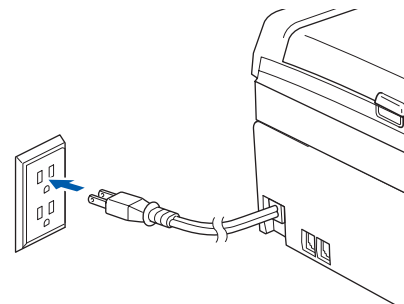



- Turn on your computer.  
You must be logged on with Administrator rights.  
Close any applications running before installing MFL-Pro Suite.



**Note**

Before installation, if you are using Personal Firewall software, disable it. After the installation, restart your Personal Firewall software.

- Put the supplied CD-ROM into your CD-ROM drive. If the model name screen appears, choose your machine. If the language screen appears, choose your language.

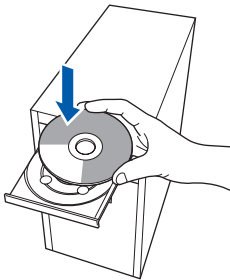

- The CD-ROM main menu will appear. Click **Install MFL-Pro Suite**.

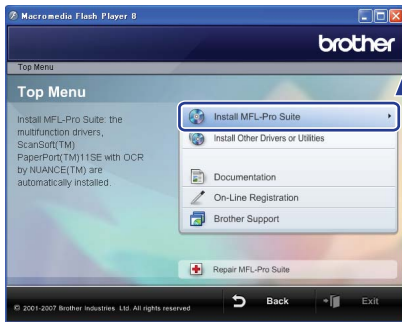

If this window does not appear, use Windows® Explorer to run the **start.exe** program from the root folder of the Brother CD-ROM.



**Note**

- If this screen appears, click **OK** and restart your computer.

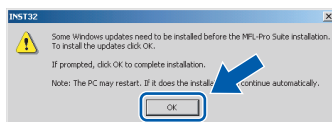

- If the installation does not continue automatically, open the main menu again by ejecting then reinserting the CD-ROM disc or double-click the **start.exe** program from the root folder, and continue from Step 9 to install MFL-Pro Suite.

- For Windows Vista™, when the User Account Control screen appears, click **Allow**.

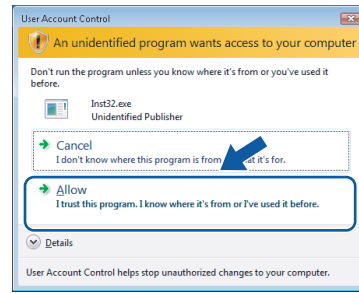

- After reading and accepting the ScanSoft™ PaperPort™ 11SE License Agreement, click **Yes**.

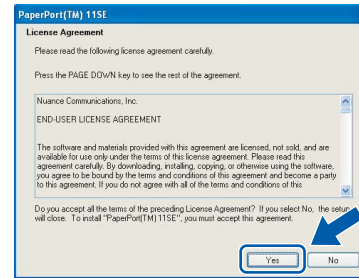

- The installation of ScanSoft™ PaperPort™ 11SE will automatically start and is followed by the installation of MFL-Pro Suite.

- When the Brother MFL-Pro Suite Software License Agreement window appears, click **Yes** if you agree to the Software License Agreement.

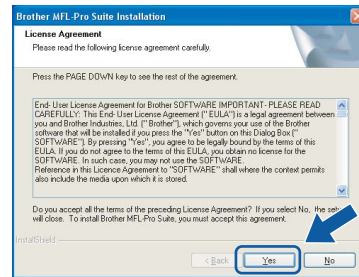

- Choose **Network Connection**, and then click **Next**.

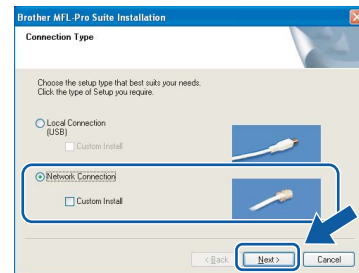

- 14** For Windows® XP SP2/Windows Vista™ users, when this screen appears, choose **Change the Firewall port settings to enable network connection and continue with the installation. (Recommended)** and click **Next**.

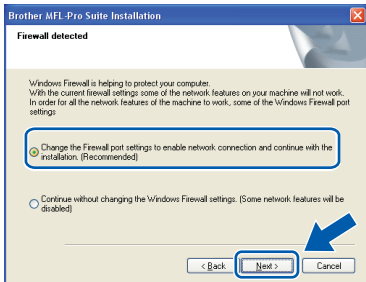

If you are not using the Windows® Firewall, see the User's Guide for your software for information on how to add the following network ports.

- For network scanning, add UDP port 54925.
- For network PC-Fax receiving, add UDP port 54926.
- If you still have trouble with your network connection, add UDP port 137.

**Note**

- If the machine is configured for your network, choose the machine from the list, and then click **Next**. This window will not appear if there is only one machine connected on the network, it will be chosen automatically.

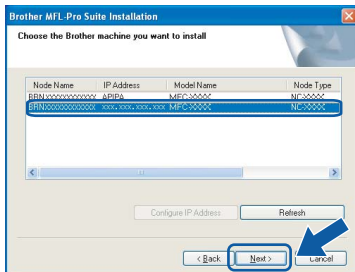

If your machine shows **APIPA** in the **IP Address** field, click **Configure IP Address** and enter an IP address for your machine that is suitable for your network.

- If the machine is not yet configured for use on your network, the following screen appears.

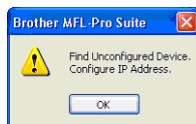

Click **OK**. The **Configure IP Address** window will appear. Enter an IP address for your machine that is suitable for your network by following the on-screen instructions.

- 15** The installation of the Brother drivers will automatically start. The installation screens appear one after another. **Please wait, it will take a few seconds for all the screens to appear.**

**Improper Setup**

**DO NOT** try to cancel any of the screens during this installation.

**Note**

For Windows Vista™, when this screen appears, click the check box and click **Install** to complete the installation properly.



- 16** When the On-Line Registration screen is displayed, make your selection and follow the on-screen instructions.

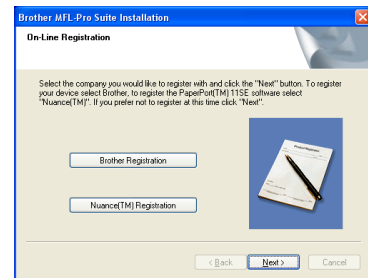

- 17** Click **Finish** to restart your computer. After restarting the computer, you must be logged on with Administrator rights.

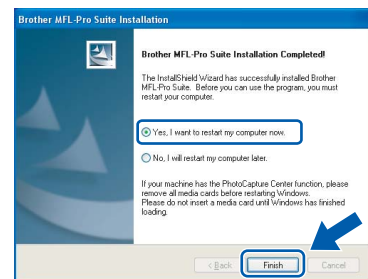

**Note**

After restarting the computer, the **Installation Diagnostics** will run automatically. If the installation is unsuccessful, the installation results window will be shown. If the Diagnostics shows a failure, please follow the on-screen instructions or read the on-line help and FAQ's in **Start/All Programs/Brother/MFC-XXXX**.



The MFL-Pro Suite has been installed completely. Proceed to *Installing FaceFilter Studio* on page 25 to install the FaceFilter Studio application.



**Note**

MFL-Pro Suite includes the Network Printer Driver, Network Scanner Driver, Brother ControlCenter3, ScanSoft™ PaperPort™ 11SE. ScanSoft™ PaperPort™ 11SE is a document management application for scanning and viewing documents.

## Installing FaceFilter Studio

FaceFilter Studio is an easy-to-use borderless photo printing application. FaceFilter Studio also lets you edit your photo data and add photo effects such as red eye reduction or skin tone enhancement.

### Important

Before you launch FaceFilter Studio for the first time, you must confirm MFL-Pro Suite is installed, your Brother machine is turned ON and connected to your network.

Windows®  
Network

**18** Open the main menu again by ejecting and then reinserting the CD-ROM disc or by double-clicking the **start.exe** program from the root folder.

**19** The CD-ROM main menu will appear. Click **Install Other Drivers or Utilities**.



**20** Click the **FaceFilter Studio** button to install.

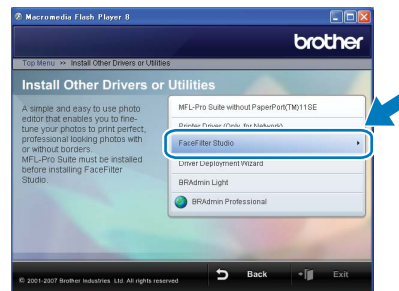

**21** For information on basic FaceFilter Studio functions, see *Using FaceFilter Studio for photo printing by REALLUSION* in the Software User's Guide on the CD-ROM. For more detailed information, install FaceFilter Studio. See *Instructions on how to install FaceFilter Studio Help (For Windows® users)* on page 34.

## For USB Interface Users (For Mac OS® X 10.2.4 or greater)

### Important

Make sure that you have finished the instructions from STEP 1 *Setting Up the Machine* on pages 4 through 14.

### Note

- For Mac OS® X 10.2.0 to 10.2.3 users, upgrade to Mac OS® X 10.2.4 or greater. (For the latest information for Mac OS® X, visit <http://solutions.brother.com>)
- Make sure there are no memory cards or a USB Flash memory drive inserted into the media drives or USB direct interface at the front of the machine.

- 1 Using both hands, use the plastic tabs on both sides of the machine to lift the scanner cover until it locks securely into the open position.

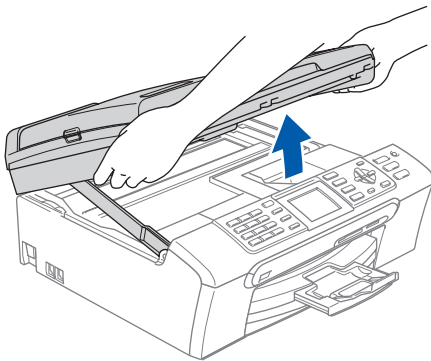

- 2 Insert the USB cable into the USB socket marked with a  symbol. You will find the USB socket inside the machine on the right as shown below.

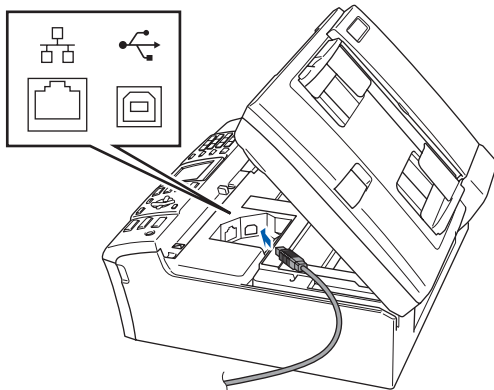

- 3 Carefully route the USB cable through the trench and out the back of the machine as shown below and connect the cable to your Macintosh®.

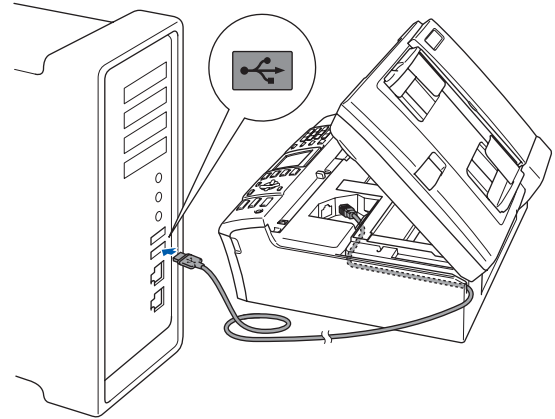

### ⊘ Improper Setup

- **DO NOT** connect the machine to a USB port on a keyboard or a non-powered USB hub. Brother recommends that you connect the machine directly to your Macintosh®.
- Make sure that the cable does not restrict the cover from closing, or an error may occur.
- Make sure you use a USB 2.0 cable that is no longer than 6 feet (2 meters) long.

- 4 Lift the scanner cover to release the lock ①. Gently push the scanner cover support down ② and close the scanner cover ③.

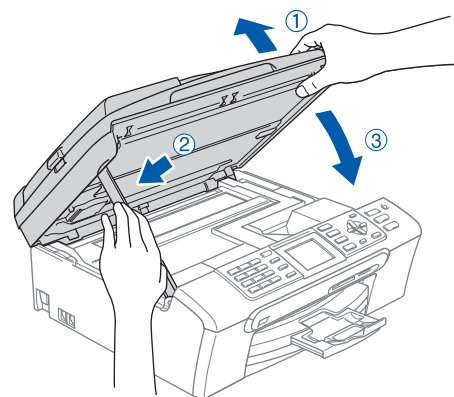

- 5** Turn on the machine by connecting the power cord.

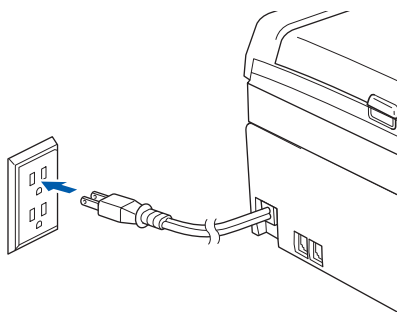

- 6** Turn on your Macintosh®.

- 7** Put the supplied CD-ROM into your CD-ROM drive.

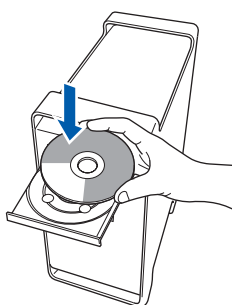

- 8** Double-click the **Start Here OSX** icon to install. Follow the on-screen instructions.



**Note**

Please wait, it will take a few seconds for the software to install. After the installation, click **Restart** to finish installing the software.

- 9** The Brother software will search for the Brother device. During this time the following screen will appear.

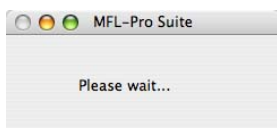

- 10** When this screen appears, click **OK**.

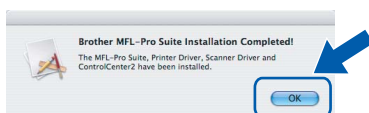

- OK!** For Mac OS® X 10.3.x or greater users: The MFL-Pro Suite, Brother printer driver, scanner driver and Brother ControlCenter2 have been installed and the installation is now complete. Go to step 15.

- 11** For Mac OS® X 10.2.4 to 10.2.8 users: Click **Add**.

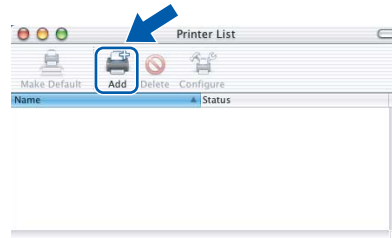

- 12** Choose **USB**.

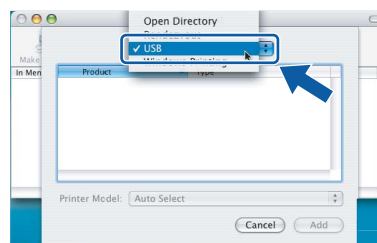

- 13** Choose **MFC-XXXX** (where XXXX is your model name), and then click **Add**.

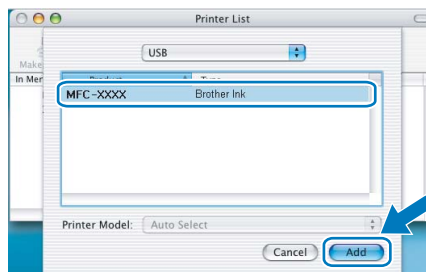

- 14** Click **Print Center**, then **Quit Print Center**.

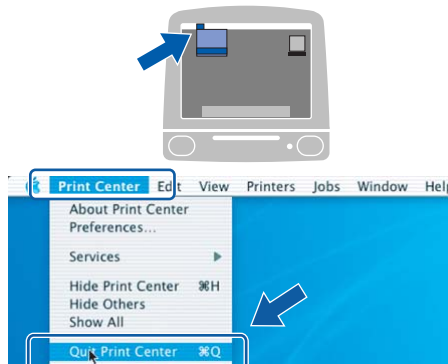

- OK!** The MFL-Pro Suite, Brother printer driver, scanner driver and Brother ControlCenter2 have been installed and the installation is now complete.

Macintosh®  
USB

- 15** To install Presto!® PageManager®, double-click the **Presto! PageManager** icon and follow the on-screen instructions.



For Mac OS® X 10.2.4 to 10.3.8 users:  
When this screen appears, click **Go** to download the software from the Brother Solutions Center web site.



 **Note**

*When Presto!® PageManager® is installed OCR capability is added to the Brother ControlCenter2. You can easily scan, share and organize photos and documents using Presto!® PageManager®.*



**Presto!® PageManager® has been installed and the installation is now complete.**

## For Network Interface Users (For Mac OS® X 10.2.4 or greater)

### Important

Make sure that you have finished the instructions from **STEP 1 Setting Up the Machine** on pages 4 through 14.

### Note

- For Mac OS® X 10.2.0 to 10.2.3 users, upgrade to Mac OS® X 10.2.4 or greater. (For the latest information for Mac OS® X, visit <http://solutions.brother.com>)
- Make sure there are no memory cards or a USB Flash memory drive inserted into the media drives or USB direct interface at the front of the machine.

- Using both hands, use the plastic tabs on both sides of the machine to lift the scanner cover until it locks securely into the open position.

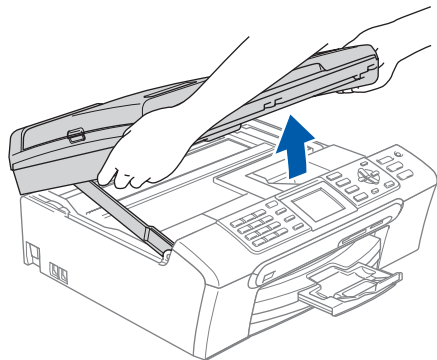

- Insert the network cable into the LAN socket marked with a  symbol. You will find the LAN socket inside the machine on the left as shown below.

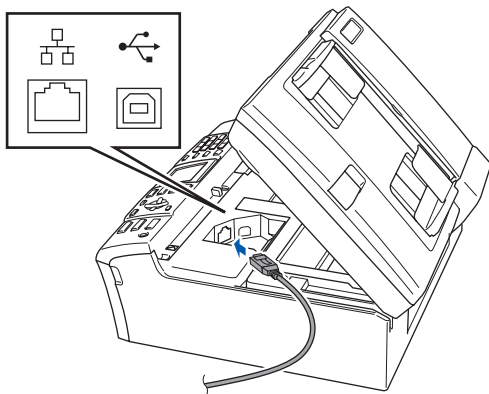

- Carefully route the network cable through the trench and out the back of the machine. Then, connect the cable to your network.

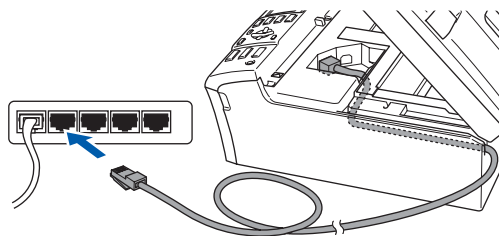

### Improper Setup

Make sure that the cable does not restrict the cover from closing, or an error may occur.

### Note

If both USB and LAN cables are being used, guide both cables through the trench with one on top of the other.

- Lift the scanner cover to release the lock ①. Gently push the scanner cover support down ② and close the scanner cover ③.

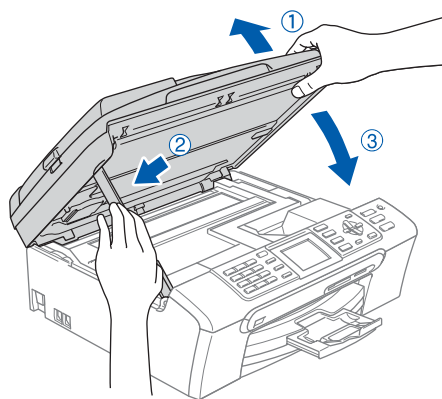

- Turn on the machine by connecting the power cord.

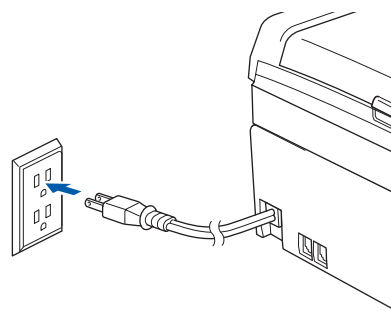

- Turn on your Macintosh®.

- 7 Put the supplied CD-ROM into your CD-ROM drive.

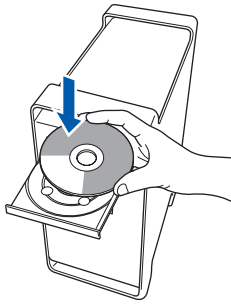

- 8 Double-click the **Start Here OSX** icon to install. Follow the on-screen instructions.



Please wait, it will take a few seconds for the software to install. After the installation, click **Restart** to finish installing the software.

- 9 The Brother software will search for the Brother device. During this time the following screen will appear.

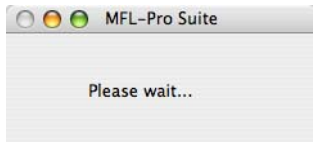

**Note**

- If the machine is configured for your network, choose the machine from the list, and then click **OK**. This window will not appear if there is only one machine connected on the network, it will be chosen automatically. Go to step 10.

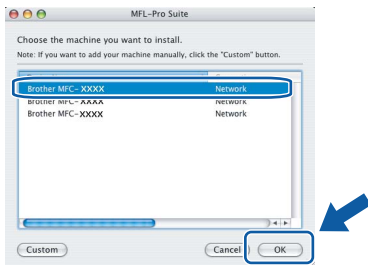

- If this screen appears click **OK**.



Enter a name for your Macintosh® in **Display Name** up to 15 characters long and click **OK**. Go to step 10.

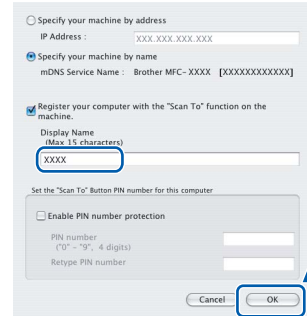

- If you want to use the machine's Scan key to scan over the network you must check the **Register your computer with the "Scan To" function on the machine box**.
- The name you enter will appear on the machine's LCD when you press the **Scan** key and choose a scan option. (For more information, see *Network Scanning in the Software User's Guide on the CD-ROM.*)

- 10 When this screen appears, click **OK**.



- OK!** For Mac OS® X 10.3.x or greater users: The MFL-Pro Suite, Brother printer driver, scanner driver and Brother ControlCenter2 have been installed and the installation is now complete. Go to step 15.

- 11 For Mac OS® X 10.2.4 to 10.2.8 users: Click **Add**.

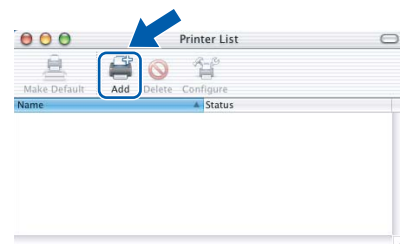



**12** Make the selection shown below.

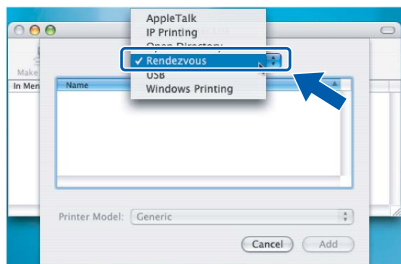

**13** Choose **MFC-XXXX** (where XXXX is your model name), and then click **Add**.

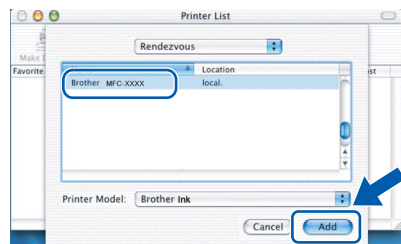

**14** Click **Print Center**, then **Quit Print Center**.

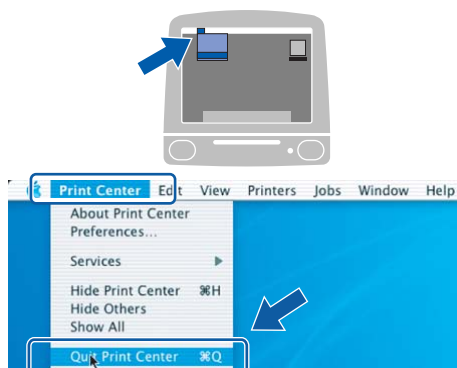

**OK!** The MFL-Pro Suite, Brother printer driver, scanner driver and Brother ControlCenter2 have been installed and the installation is now complete.

**15** To install Presto!® PageManager®, double-click the **Presto! PageManager** icon and follow the on-screen instructions.



For Mac OS® X 10.2.4 to 10.3.8 users:  
When this screen appears, click **Go** to download the software from the Brother Solutions Center web site.



**Note**

*When Presto!® PageManager® is installed OCR capability is added to the Brother ControlCenter2. You can easily scan, share and organize photos and documents using Presto!® PageManager®.*

**OK!** Presto!® PageManager® has been installed and the installation is now complete.

## BRAdmin Light utility (For Windows® users)

BRAdmin Light is a utility for initial setup of Brother network connected devices. It also can search for Brother products on your network, view the status and configure basic network settings, such as IP address. For more information on BRAdmin Light, visit us at <http://solutions.brother.com>.

### Note

If you require more advanced printer management, use the latest Brother BRAdmin Professional utility version that is available as a download from <http://solutions.brother.com>.

## Installing the BRAdmin Light configuration utility

- 1 Click **Install Other Drivers or Utilities** on the menu screen.



- 2 Click **BRAdmin Light** and follow the on-screen instructions.

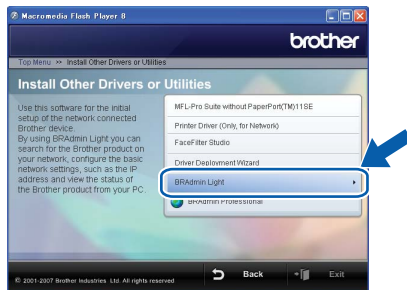

## Setting your IP address, Subnet Mask and Gateway using BRAdmin Light

### Note

If you have a DHCP/BOOTP/RARP server in your network, you don't have to do the following operation. Because the print server will automatically obtain its IP address.

- 1 Start BRAdmin Light. It will search for new devices automatically.

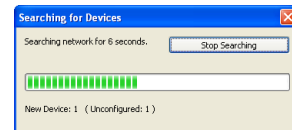

- 2 Double-click the unconfigured device.

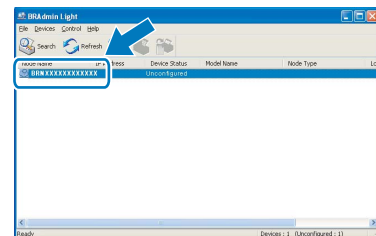

- 3 Choose **STATIC** for the **Boot Method**. Enter the **IP Address**, **Subnet Mask** and **Gateway**, and then click **OK**.

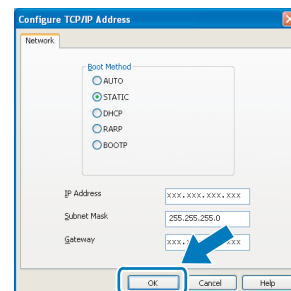

- 4 The address information will be saved to the machine.

## BRAdmin Light utility (For Mac OS<sup>®</sup> X users)

BRAdmin Light is a utility for initial setup of Brother network connected devices. It also can search for Brother products on your network, view the status and configure basic network settings, such as IP address from a computer running Mac OS<sup>®</sup> X 10.2.4 or greater.

The BRAdmin Light software will be installed automatically when you install the printer driver. If you have already installed the printer driver, you don't have to install it again. For more information on BRAdmin Light, visit us at <http://solutions.brother.com>.

### Setting your IP address, Subnet Mask and Gateway using BRAdmin Light

#### Note

- If you have a DHCP/BOOTP/RARP server in your network, you don't have to do the following operation. The print server will automatically obtain its own IP address.
- Make sure that version 1.4.1\_07 or later of Java™ client software is installed on your computer.

- 1 Double-click the **Macintosh HD** icon on your desktop.

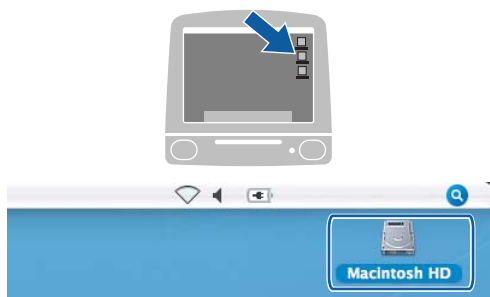

- 2 Choose **Library, Printers, Brother** and then **Utilities**.

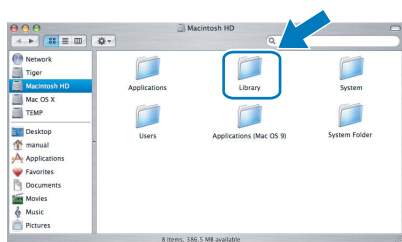

- 3 Double-click the file **BRAdmin Light.jar** and run the software. BRAdmin Light will then search for new devices automatically.

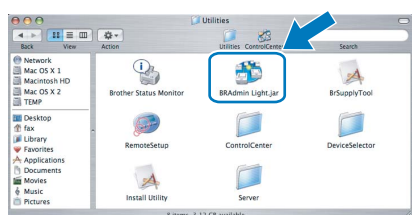

- 4 Double-click the unconfigured device.

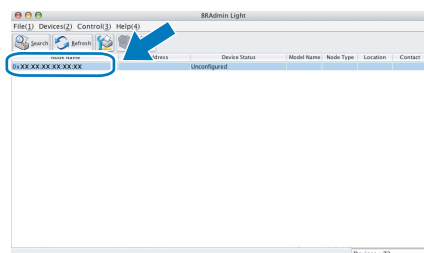

- 5 Choose **STATIC** for the **Boot Method**. Enter the **IP Address, Subnet Mask** and **Gateway**, and then click **OK**.

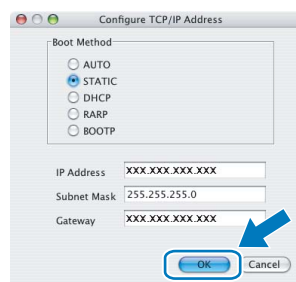

- 6 The address information will be saved to the machine.

## Instructions on how to install FaceFilter Studio Help (For Windows® users)

To get instructions on how to use FaceFilter Studio, download and install FaceFilter Studio Help. Your computer must be connected to the internet.

### Installing FaceFilter Studio Help

- 1** To run FaceFilter Studio, go to **Start/All Programs/FaceFilter Studio/FaceFilter Studio** in the **Start** menu.
- 2** Click the **?** button on the upper right corner of the screen.
- 3** Click **Check for updates** to go to the Reallusion update web page.

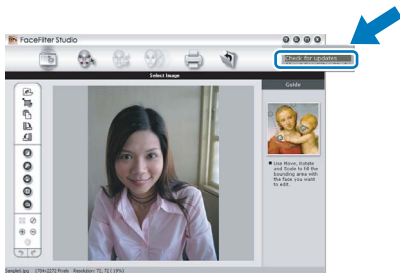

- 4** Click the **Download** button and choose a folder to save the file in.

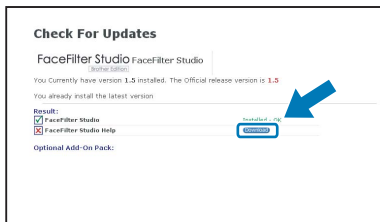

- 5** Close FaceFilter Studio before you start the installer for FaceFilter Studio Help. Double-click the downloaded file from the folder you specified and follow the on-screen instructions for installation.



#### **Note**

To view the complete FaceFilter Studio Help, choose **Start/All Programs/FaceFilter Studio/FaceFilter Studio Help** on your computer.

## Replacement consumables

When the time comes to replace ink cartridges, an error message will be indicated on the LCD. For more information about the ink cartridges for your machine, visit <http://solutions.brother.com> or contact your local Brother re-seller.

### Ink cartridge

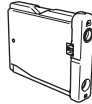
Black	Yellow	Cyan	Magenta
LC51BK	LC51Y	LC51C	LC51M
			

#### What is Innobella™?

Innobella™ is a range of genuine consumables offered by Brother. The name "Innobella™" derives from the words "Innovation" and "Bella" (meaning "Beautiful" in Italian) and is a representation of the "innovative" technology providing you with beautiful and long lasting print results.



## **Trademarks**

The Brother logo is a registered trademark of Brother Industries, Ltd.

Brother is a registered trademark of Brother Industries, Ltd.

Multi-Function Link is a registered trademark of Brother International Corporation.

Microsoft and Windows are registered trademarks of Microsoft Corporation in the United States and /or other countries.

Windows Vista is either a registered trademark or trademark of Microsoft Corporation in the United States and /or other countries.

Macintosh and TrueType are registered trademarks of Apple Inc.

Nuance, the Nuance logo, PaperPort and ScanSoft are trademarks or registered trademarks of Nuance Communications, Inc. or its affiliates in the United States and/or other countries.

Presto! PageManager is a registered trademark of NewSoft Technology Corporation.

PictBridge is a trademark.

FaceFilter Studio is a trademark of Reallusion, Inc.

Each company whose software title is mentioned in this manual has a Software License Agreement specific to its proprietary programs.

**All other brand and product names mentioned in this manual are trademarks or registered trademarks of their respective companies.**

## **Compilation and Publication**

Under the supervision of Brother Industries Ltd., this manual has been compiled and published, covering the latest product descriptions and specifications.

The contents of this manual and the specifications of this product are subject to change without notice.

Brother reserves the right to make changes without notice in the specifications and materials contained herein and shall not be responsible for any damages (including consequential) caused by reliance on the materials presented, including but not limited to typographical and other errors relating to the publication.

## **Copyright and License**

©2007 Brother Industries, Ltd.

This product includes software developed by the following vendors.

©1998-2007 TROY Group, Inc.

©1983-2007 PACIFIC SOFTWARES INC.

**brother**®

USA/CAN