

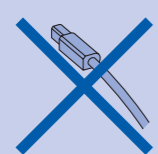

Start Here

Important

DO NOT connect the USB cable yet.



WARNING Warnings tell you what to do to prevent possible personal injury.

1 Unpack the machine and check the components

1

Note

- The components of your box may differ depending on your country.
 - Save all packing materials and the box in case for any reason you must ship your machine.
 - A USB cable is not included.
- You need to purchase a USB 2.0 cable that is no more than 6 feet (2 meters) long.
- Your machine has a USB 2.0 Full-speed interface. This interface is compatible with USB 2.0 Hi-Speed; however, the maximum data transfer rate will be 12 Mbits/s. The machine can also be connected to a computer that has a USB 1.1 interface.

c. Make sure you have all components.



WARNING

Plastic bags are used in the packaging of your machine. To avoid danger of suffocation, please keep these bags away from babies and children.

- a.** Remove the protective tape and film.
- b.** Remove the plastic bag containing the ink cartridges from on top of the paper tray.

2 Load plain Letter/A4 paper

2

a. Pull out the paper tray.

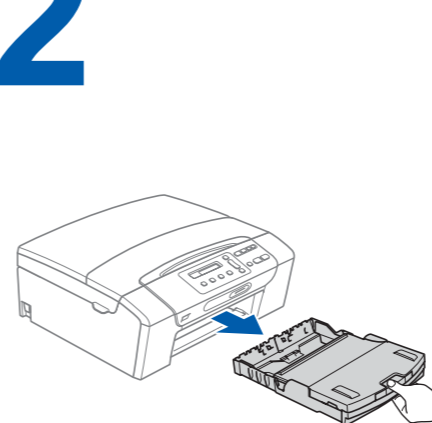

b. Lift the paper tray cover.

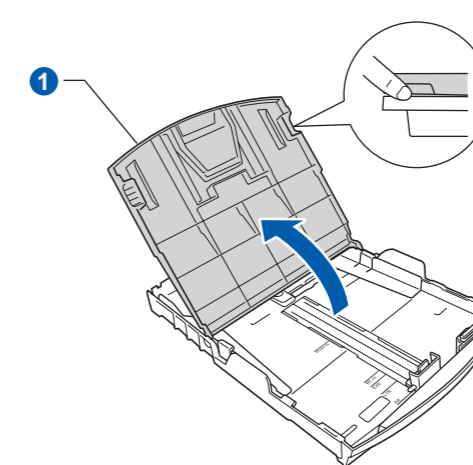

c. Press and slide the paper side guides and paper length guide to fit the paper size.

Make sure that the triangular marks on the paper side guides and paper length guide line up with the mark for the paper size you are using.

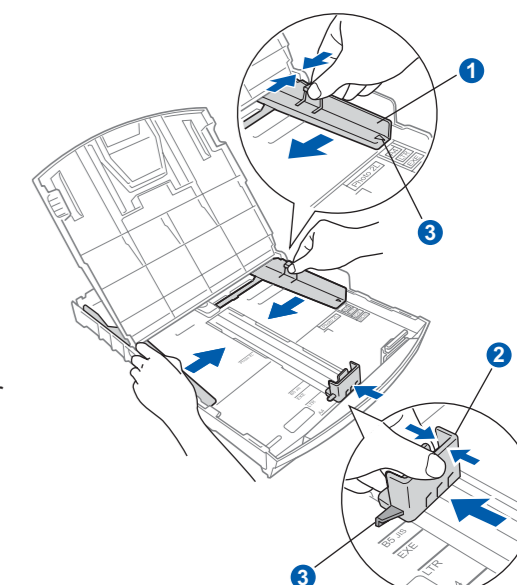

e. Gently put the paper into the paper tray. Check that the paper is flat in the tray.

Note

When you use Legal size paper, press and hold the universal guide release button as you slide out the front of the paper tray.

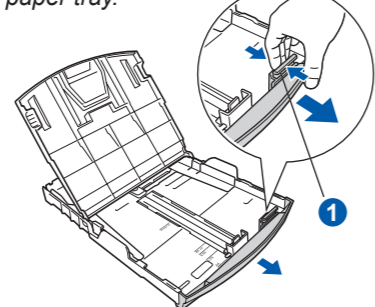

f. Gently adjust the paper side guides to the paper with both hands. Make sure the paper side guides touch the edges of the paper.

g. Close the paper tray cover and slowly push the paper tray back into the machine.

h. Pull out the paper support until it clicks, and then unfold the paper support flap.

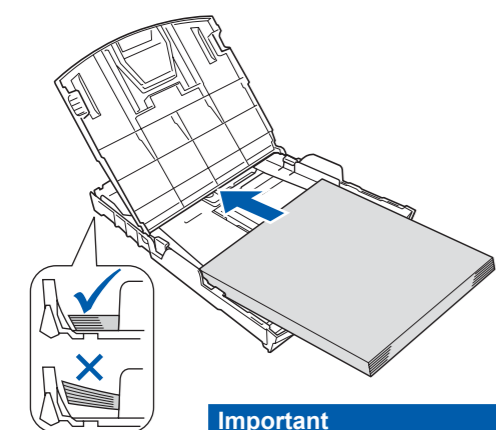
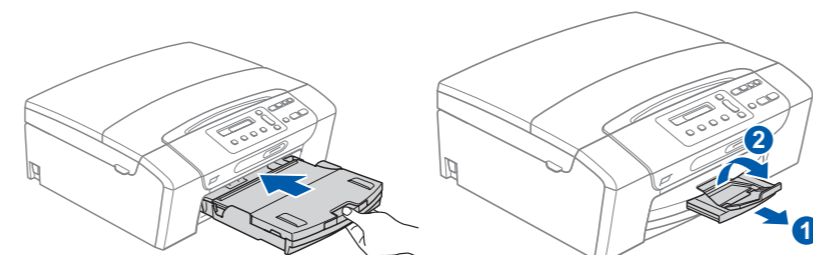

d. Fan the stack of paper well.

Important

Do not push the paper in too far.

3 Connect the power cord

3

a. Connect the power cord.

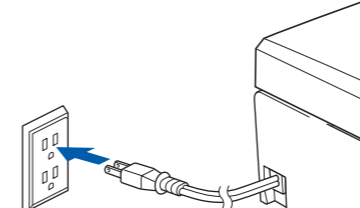

Important

DO NOT connect the USB cable yet.

Note

The control panel warning LED will stay on until you have installed the ink cartridges.

4 Install the ink cartridges

4

a. The LCD shows:



b. Open the ink cartridge cover.

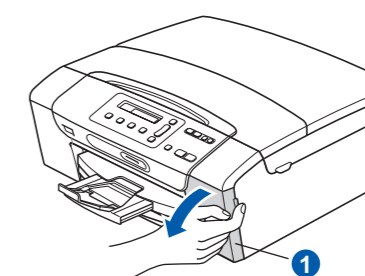

c. Remove the green protective part.

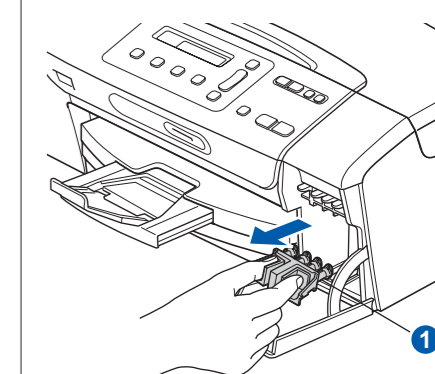

d. Unpack the ink cartridge. Turn the green knob on the protective yellow cap clockwise until it clicks to release the vacuum seal, then remove the cap.

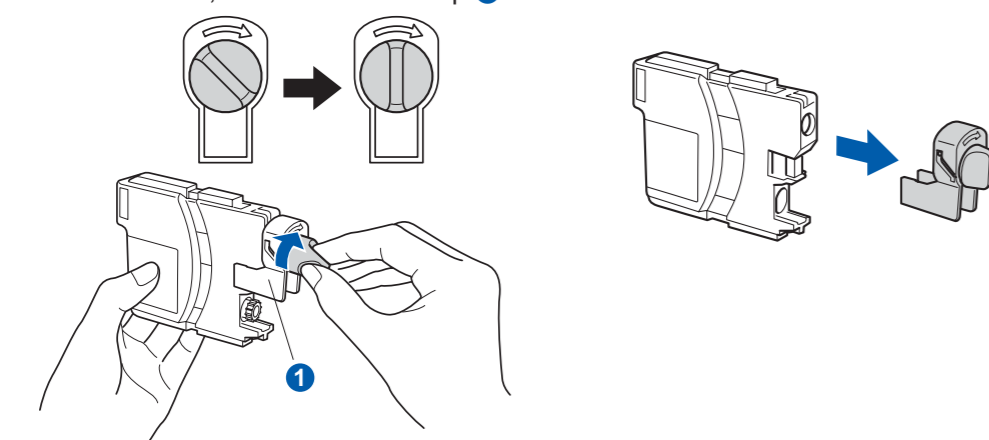

e. Install each ink cartridge in the direction of the arrow on the label. Take care to match the color of the lever with the cartridge color.

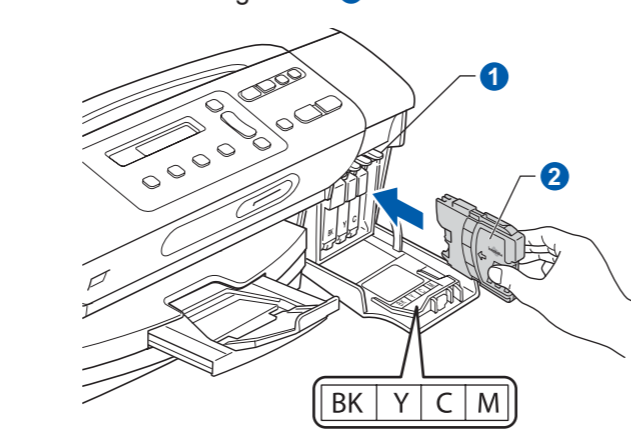

f. Gently push the ink cartridge until it clicks. After all the ink cartridges are installed close the ink cartridge cover.

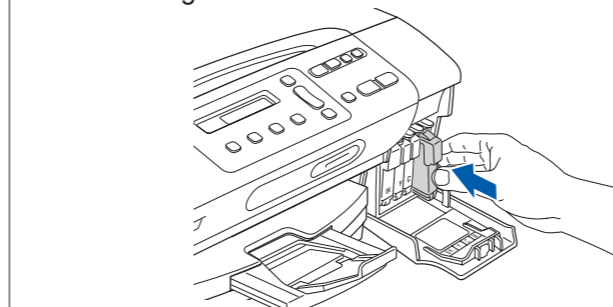

Note

The machine will prepare the ink tube system for printing. This process will take approximately four minutes. Do not turn off the machine.

5 Check the print quality

5

a. When the preparation process has finished, the LCD shows this message.

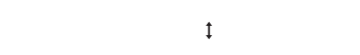

Press Color Start.

b. Check the quality of the four color blocks on the sheet. (black/yellow/cyan/magenta)



If all lines are clear and visible, press **▲** (Yes) to finish the quality check.

If you can see missing short lines, press **▼** (No) and follow the steps on the LCD.

OK

Poor

6 Set the language (If needed)

6

- Press **Menu**.
- Press **▲** or **▼** to choose 0.Initial Setup, and then press **OK**.
- Press **▲** or **▼** to choose 0.Local Language, and then press **OK**.
- Press **▲** or **▼** to choose your language.
- Press **OK** and then **Stop/Exit**.

7 Set the LCD contrast (If needed)

7

- Press **Menu**.
- Press **▲** or **▼** to choose 0.Initial Setup, and then press **OK**.
- Press **▲** or **▼** to choose 2.LCD Contrast, and then press **OK**.
- Press **▲** or **▼** to choose Dark or Light.
- Press **OK** and then **Stop/Exit**.

8 Set the date and time

8

- Press **Menu**.
- Press **▲** or **▼** to choose 0.Initial Setup, and then press **OK**.
- Press **▲** or **▼** to choose 1.Date&Time, and then press **OK**.
- Press **▲** or **▼** repeatedly to enter the last two digits of the year, and then press **OK**.
- Repeat for Month and Day, and Hours and Minutes in 24-hour format.
- Press **Stop/Exit**.

Note

If you make a mistake and want to start again, press **Stop/Exit** to go back to step a.



Turn the sheet over.

For Windows®

Before you install

9 a. Make sure that your computer is ON and you are logged on with Administrator rights.

- Important**
- DO NOT connect the USB cable yet.
 - Close any applications.
 - Make sure there are no memory cards or a USB Flash memory drive inserted.
 - The screen may differ depending on the operating system.
 - The supplied CD-ROM includes ScanSoft™ PaperPort™ 11SE.
 - This software supports Windows® 2000 (SP4 or greater), XP (SP2 or greater), XP Professional x64 Edition and Windows Vista®. Update to the latest Windows® Service Pack before installing MFL-Pro Suite.
 - For Windows Vista®, when the User Account Control screen appears, click **Allow**.

b. Unplug the machine.

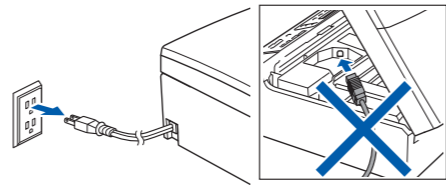

Install MFL-Pro Suite

10 a. Insert the supplied CD-ROM into your CD-ROM drive. Choose your language.

- Note**
- If the Brother screen does not appear automatically, go to **My Computer (Computer)**, double-click the CD-ROM icon, and then double-click **start.exe**.

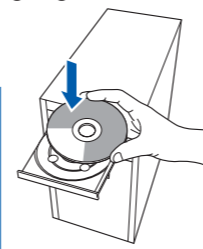

Connect the USB cable

b. Click **Install MFL-Pro Suite**, and click **Yes** if you accept the license agreements.

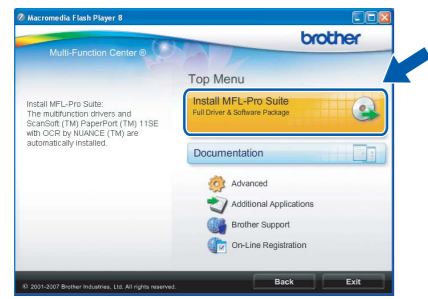

c. Follow the on-screen instructions until this screen appears:

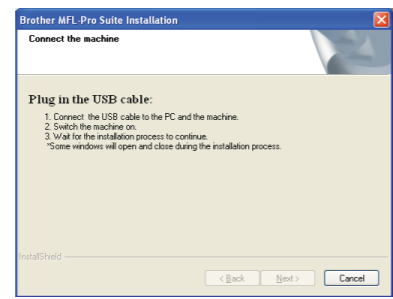

11 a. Lift the scanner cover until it locks securely into the open position.

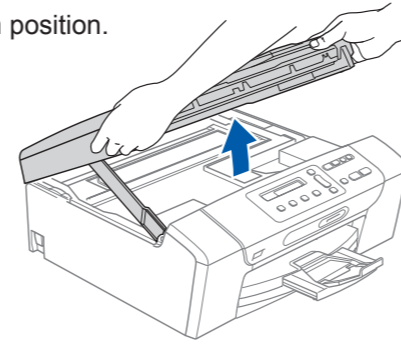

b. Connect the USB cable to the USB socket marked with a symbol. The USB socket is inside the machine as shown.

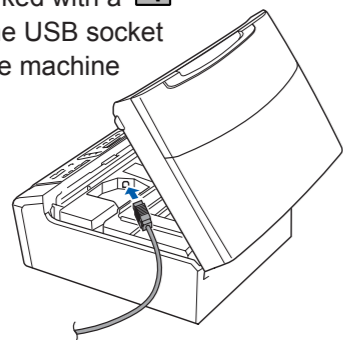

c. Carefully route the USB cable through the cable channel and out the back of the machine. Connect the cable to your computer.

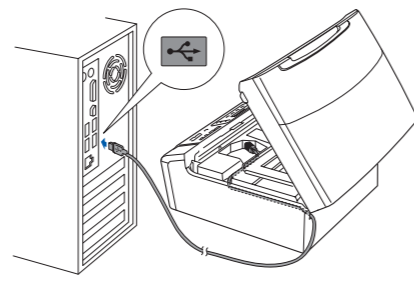

- Important**
- DO NOT connect the machine to a USB port on a keyboard or a non-powered USB hub. Connect the machine directly to your computer.
 - Make sure that the cable does not restrict the cover from closing, or an error may occur.

d. Lift the scanner cover to release the lock ①. Gently push the scanner cover support down ② and close the scanner cover ③.

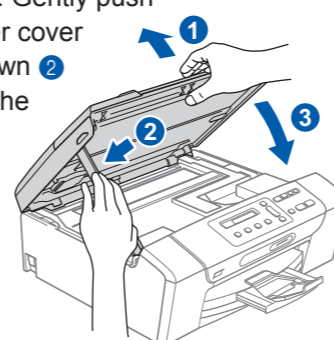

Connect the power cord

12 a. Connect the power cord.

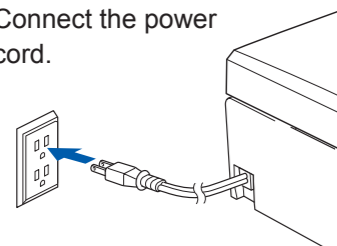

- Important**
- DO NOT cancel any of the screens. It may take a few minutes for installation to complete.

The installation will continue automatically. The installation screens appear one after another.

b. When the **On-Line Registration** screen appears, make your selection and follow the on-screen instructions.

Finish and restart

13 a. Click **Finish** to restart your computer.

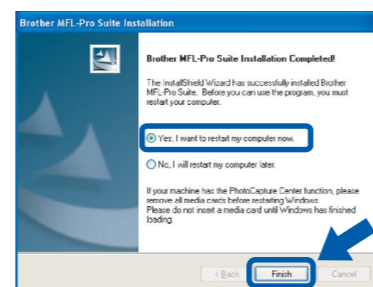

Finish The installation is now complete.

- Note**
- If an error message appears during the software installation, run the **Installation Diagnostics** located in **Start/All Programs/Brother/DCP-XXXX** (where DCP-XXXX is your model name).

Install Optional Applications supported by Reallusion, Inc

14 FaceFilter Studio lets you edit your photo data and add photo effects such as red eye reduction or skin tone enhancement.

- Important**
- The computer must be connected to the internet.
 - The machine must be ON and connected to the computer.

a. Open the main menu again by ejecting and then reinserting the CD-ROM or by double-clicking the **start.exe** program from the root folder.

b. The CD-ROM main menu will appear. Choose your language and then click **Additional Applications**.

c. Click the **FaceFilter Studio** button to install.

- Note**
- You can also install **BookScan&Whiteboard Suite** from the main menu.

Install FaceFilter Studio Help

15 a. Go to **Start/All Programs/Reallusion/FaceFilter Studio** on your computer.

b. Click the button on the upper right corner of the screen, and then click **Check for updates** to go to the Reallusion update web page.



c. Click the **Download** button and choose a folder to save the file in.

d. Close FaceFilter Studio, double-click the downloaded file from the folder you specified, and then follow the on-screen instructions to install.

- Note**
- To view **FaceFilter Studio Help**, go to **Start/All Programs/Reallusion/FaceFilter Studio/FaceFilter Studio Help** on your computer.

For Mac OS® X

Before you install

9 Make sure your machine is connected to the power and your Macintosh® is ON. You must be logged on with Administrator rights.

- Important**
- Make sure there are no memory cards or a USB Flash memory drive inserted.
 - For Mac OS® X 10.2.0 to 10.2.3 users, upgrade to Mac OS® X 10.2.4 or greater. (For the latest information for Mac OS® X, visit <http://solutions.brother.com/>)

Connect the USB cable

10 a. Lift the scanner cover until it locks securely into the open position.

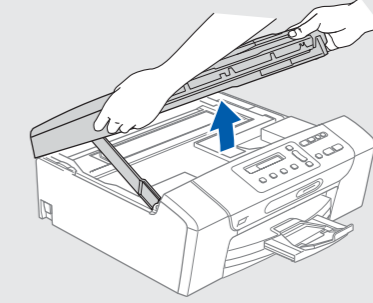

b. Connect the USB cable to the USB socket marked with a symbol. The USB socket is inside the machine as shown below.

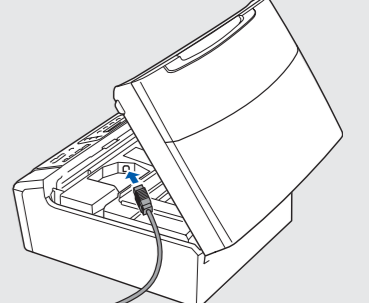

c. Carefully route the USB cable through the cable channel and out the back of the machine.

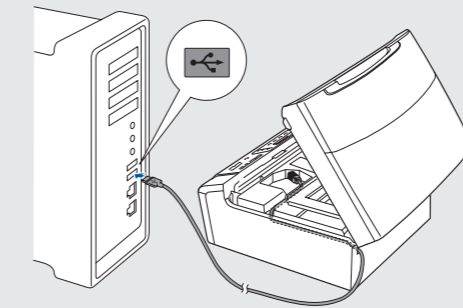

- Important**
- DO NOT connect the machine to a USB port on a keyboard or a non-powered USB hub. Connect the machine directly to your Macintosh®.
 - Make sure that the cable does not restrict the cover from closing, or an error may occur.

e. Lift the scanner cover to release the lock ①. Gently push the scanner cover support down ② and close the scanner cover ③.

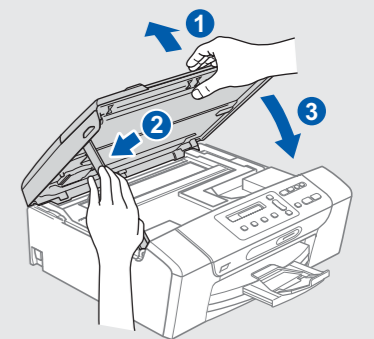

Install MFL-Pro Suite

11 a. Insert the supplied CD-ROM into your CD-ROM drive.

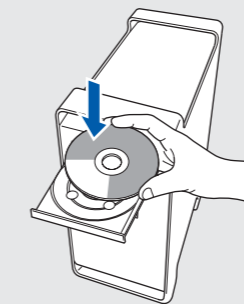

b. Double-click the **Start Here OSX** icon.

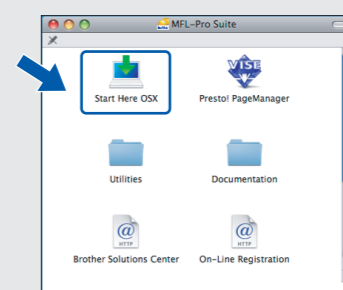

- Note**
- It may take a few minutes for installation to complete. After the installation, click **Restart**.

c. Click **OK**.

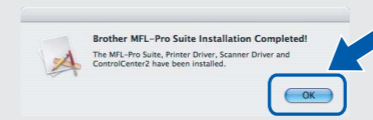

For Mac OS® X 10.3.x or greater users, go to step 12.

d. For Mac OS® X 10.2.4 to 10.2.8 users, click **Add** and then choose **USB**.

e. Choose your model name, and then click **Add**.

f. Quit **Print Center**.

Install Presto!® PageManager®

12 When Presto!® PageManager® is installed, OCR capability is added to Brother ControlCenter2. With Presto!® PageManager®, you can easily scan, share and organize photos and documents.

a. Double-click the **Presto! PageManager** icon and follow the on-screen instructions.

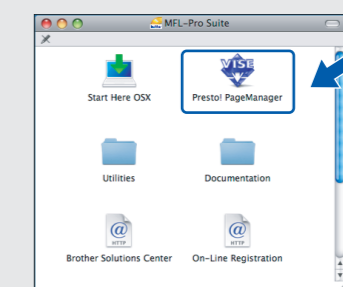

Finish
The installation is now complete.